

**TECHNICAL BULLETIN
INSTALLATION INSTRUCTIONS
FOR EPLRS NETWORK MANAGER VEHICLE
WITH AMTECH TOP**

FOR SYSTEMS

**SINGLE CHANNEL GROUND AND AIRBORNE
RADIO SYSTEM (SINGARS)
AN/VRC-92F**

**FORCE XXI BATTLE COMMAND, BRIGADE-AND-BELOW (FBCB2)
AN/UYK-128 (V)4**

**PRECISION LIGHTWEIGHT GPS RECEIVER (PLGR)
AN/PSN-11**

**ENHANCED POSITION LOCATION REPORTING SYSTEM (EPLRS)
AN/VSQ-2 (V)**

QUICK-ERECT ANTENNA MASTS (QEAM)

**REMOTE REKEY DEVICE
KOK-13**

NETWORK MANAGER AND PRINTER

SUPPLEMENTAL BATTERIES

FOR VEHICLES

**TRUCK, UTILITY, 2/4-DOOR: HEAVY VARIANT, 1-1/4 TON, 4X4,
M1097A2 (2320-01-380-8604) (EIC: BB6).**

Approved for public release; distribution is unlimited.

HEADQUARTERS, DEPARTMENT OF THE ARMY

FEBRUARY 2006

CHANGE
NO. 1

HEADQUARTERS
DEPARTMENT OF THE ARMY,
Washington, D.C., 1 OCTOBER 2006

**TECHNICAL BULLETIN
INSTALLATION INSTRUCTIONS
FOR EPLRS NETWORK MANAGER VEHICLE WITH AMTECH TOP**

FOR SYSTEMS

**SINGLE CHANNEL GROUND AND AIRBORNE
RADIO SYSTEM (SINCGARS)
AN/VRC-92F**

**FORCE XXI BATTLE COMMAND, BRIGADE-AND-BELOW (FBCB2)
AN/UYK-128 (V)4**

**PRECISION LIGHTWEIGHT GPS RECEIVER (PLGR)
AN/PSN-11**

**ENHANCED POSITION LOCATION REPORTING SYSTEM (EPLRS)
AN/VSQ-2 (V)**

QUICK-ERECT ANTENNA MASTS (QEAM)

**REMOTE REKEY DEVICE
KOK-13**

NETWORK MANAGER AND PRINTER

SUPPLEMENTAL BATTERIES

FOR VEHICLES

**TRUCK, UTILITY, 2/4-DOOR: HEAVY VARIANT, 1-1/4 TON, 4X4,
M1097A2 (2320-01-380-8604) (EIC: BB6).**

TB 9-2320-280-35-12, 28 February 2006, is changed as follows:

1. Remove old pages and insert new pages as indicated below.
2. New or changed material is indicated by a vertical bar in the margin of the page.

Remove pages

A/(B blank)
i through iv
4-3 through 4-8
5-11 through 5-16
5-49 and 5-50
5-53 and 5-54
5-59 and 5-60
None
DA Form 2028

Insert page

A/(B blank)
i through iv
4-3 through 4-8
5-11 through 5-16
5-49 and 5-50
5-53 and 5-54
5-59 and 5-60
5-107 through 5-117/(5-118 blank)
DA Form 2028

3. File this change sheet in front of the publication for reference purposes.

Approved for public release; distribution is unlimited.

By Order of the Secretary of the Army:

PETER J. SCHOOMAKER
General, United States Army
Chief of Staff

Official:

A handwritten signature in black ink that reads "Joyce E. Morrow". The signature is written in a cursive, flowing style.

JOYCE E. MORROW
Administrative Assistant to the
Secretary of the Army
0620103

Distribution:

To be distributed in accordance with the Initial Distribution Number (IDN) 344840 requirements for TB 9-2320-280-35-12.

LIST OF EFFECTIVE PAGES

NOTE

A vertical line in the outer margins of the page indicates the portion of text affected by the change.

Dates of issue for original and change pages are:

Original 0 28 February 2006

Change 1 1 October 2006

TOTAL NUMBER OF PAGES IN THIS PUBLICATION IS 151 PAGES.

Page No.....	*Change No.
A/(B blank)	1
i through iv	1
1-1-4-2	0
4-3-4-4	1
4-5	0
4-6-4-8	1
4-9-5-11	0
5-12	1
5-12.1-5-12.4 Added	1
5-13	1
5-14	0
5-15	1
5-16-5-49	0
5-50	1
5-51-5-53	0
5-54	1
5-55-5-59	0
5-60	1
5-61-5-106	0
5-107-5-117/(5-118 blank) Added	1
A-1/(A-2 blank)	0

*Zero in this column indicates original page.

TECHNICAL BULLETIN
NO. 9-2320-280-35-12

HEADQUARTERS,
DEPARTMENT OF THE ARMY
WASHINGTON, D.C., 28 February 2006

**TECHNICAL BULLETIN
INSTALLATION INSTRUCTIONS
FOR EPLRS NETWORK MANAGER VEHICLE WITH AMTECH TOP**

FOR SYSTEMS

**SINGLE CHANNEL GROUND AND AIRBORNE
RADIO SYSTEM (SINCGARS)
AN/VRC-92F**

**FORCE XXI BATTLE COMMAND, BRIGADE-AND-BELOW (FBCB2)
AN/UYK-128 (V)4**

**PRECISION LIGHTWEIGHT GPS RECEIVER (PLGR)
AN/PSN-11**

**ENHANCED POSITION LOCATION REPORTING SYSTEM (EPLRS)
AN/VSQ-2 (V)**

QUICK-ERECT ANTENNA MASTS (QEAM)

**REMOTE REKEY DEVICE
KOK-13**

NETWORK MANAGER AND PRINTER

SUPPLEMENTAL BATTERIES

FOR VEHICLES

**TRUCK, UTILITY, 2/4-DOOR: HEAVY VARIANT, 1-1/4 TON, 4X4,
M1097A2 (2320-01-380-8604) (EIC: BB6).**

REPORTING ERRORS AND RECOMMENDING IMPROVEMENTS

You can help improve this publication. If you find any mistakes or if you know of a way to improve the procedures, please let us know. Submit your DA Form 2028 (Recommended Changes to Publications and Blank Forms), through the Internet, on the Army Electronic Product Support (AEPS) website. The Internet address is <https://aeeps.ria.army.mil>. The DA Form 2028 is located in the ONLINE FORMS PROCESSING section of the AEPS. Fill out the form and click on SUBMIT. Using this form on the AEPS will enable us to respond quicker to your comments and better manage the DA Form 2028 program. You may also mail, fax or E-mail your letter or DA Form 2028 direct to: AMSTA-LC-LPIT / TECH PUBS, TACOM-RI, 1 Rock Island Arsenal, Rock Island, IL 61299-7630. The E-mail address is tacom-tech-pubs@ria.army.mil. The fax number is DSN 793-0726 or Commercial (309) 782-0726.

Approved for public release; distribution is unlimited.

TABLE OF CONTENTS

		Page
	LIST OF TABLES	iv
CHAPTER 1.	INTRODUCTION	1-1
Section I.	Scope	1-1
Section II.	Notes	1-1
Section III.	General Information	1-1
Section IV.	Maintenance Forms, Records, and Reports	1-1
Section V.	Consolidated Index of Army Publications	1-1
CHAPTER 2.	PURPOSE OF INSTALLATION	2-1
CHAPTER 3.	COMPLETION TIME FOR INSTALLATION	3-1
CHAPTER 4.	PREPARATION FOR INSTALLATION	4-1
Section I.	Preparation of Vehicle	4-1
Section II.	Items to be Removed	4-1
Section III.	List of Items to be Retained	4-1
Section IV.	Preparation of C4ISR Equipment	4-1
Section V.	Precautions During Handling	4-1
Section VI.	Unpack and Inspect Equipment	4-1
Section VII.	Inventory C4ISR Equipment	4-1
Section VIII.	Examine Each Item for Damage	4-2
Section IX.	C4ISR Equipment, Distribution, and Consumables	4-2
Section X.	Distribution and Issue Instructions	4-2
Section XI.	Parts List	4-2
CHAPTER 5.	INSTALLATION PROCEDURES	5-1
Section I.	Scope	5-1
Section II.	Battery Box Preparations	5-1
Section III.	Integrated Rack Installation	5-7
Section IV.	SINGARS Mounting Tray and Amp Guard Installation	5-9
Section V.	Power Amplifier Installation	5-10
Section VI.	FBCB2 Components Installation	5-12
Section VI.A.	Serial Interface Adapter Device (SIAD) Cables Installation	5-12.2
Section VI.B.	Serial Interface Adapter Device (SIAD) Installation	5-12.3
Section VI.C.	FBCB2 Cables Installation	5-12.4
Section VII.	PLGR Bracket Installation	5-14
Section VIII.	PLGR Antenna and Cable Installation (Without Bolt-On Armor)	5-15
Section IX.	Loudspeaker Installation	5-17
Section X.	Loudspeaker Cable Installation	5-18
Section XI.	Computer Stand Assembly Installation	5-20
Section XII.	URO Bracket Installation	5-21

TABLE OF CONTENTS (Contd)

	Page
Section XIII.	Master Kill Switch Box Installation 5-22
Section XIV.	Computer Stand Cable Installation 5-23
Section XV.	Multi-Net Rack Installation 5-25
Section XVI.	EPLRS Dual Mount Installation 5-30
Section XVII.	Printer Installation 5-31
Section XVIII.	KOK-13 Crypto Generator Installation 5-33
Section XIX.	Battery Alarm Box Installation 5-34
Section XX.	Inverter Installation 5-35
Section XXI.	Rear Battery Box Installation 5-37
Section XXII.	AC Distribution Box Installation 5-38
Section XXIII.	AC Output Selection Box Installation 5-39
Section XXIV.	DC Charger Installation 5-40
Section XXV.	External Power Reception Box Installation 5-42
Section XXVI.	EPLRS Antenna Installation 5-44
Section XXVII.	Left-Side SINGARS Antenna Mount Installation 5-45
Section XXVIII.	Right-Side SINGARS Antenna Mount Installation 5-51
Section XXIX.	Vehicle Ground Installation 5-55
Section XXX.	QEAM: Antennas and Brackets Installation 5-56
Section XXXI.	SINGARS Antenna Cable Installation 5-60
Section XXXII.	PLGR Power Cable Installation 5-64
Section XXXIII.	Left-Side EPLRS Antenna Cable Installation 5-65
Section XXXIV.	Right-Side EPLRS Antenna Cable Installation 5-69
Section XXXV.	Computer Stand Tunnel Cable Installation 5-72
Section XXXVI.	Master Kill Switch Cable Installation 5-75
Section XXXVII.	Remote Curbside Separator Cable Installation 5-76
Section XXXVIII.	External Power Reception Box Cable Installation 5-79
Section XXXIX.	DC Charger Cable Installation 5-82
Section XL.	AC Distribution Box Cable Installation 5-84
Section XLI.	AC Output Selection Box Cable Installation 5-85
Section XLII.	Inverter Cable Installation 5-86
Section XLIII.	Rear Battery Cable Installation 5-87
Section XLIV.	Multi-Net Rack Rear Cable Installation 5-88
Section XLV.	Driver-Side Multi-Net Rack Cable Installation 5-90
Section XLVI.	Passenger-Side Multi-Net Rack Cable Installation 5-94

TABLE OF CONTENTS (Contd)

		Page
Section XLVII.	C4ISR Power Cable Installation	5-96
Section XLVIII.	Windshield Armor Modification	5-107
Section XLIX.	Armor and Antenna Installation (With Bolt-On Armor)	5-110
Section L.	Antenna Cable Installation	5-114

LIST OF TABLES

Table	Title	Page
4-1.	Kits Parts List for Installation of C4ISR Equipment	4-3
4-2.	Non-Kit Parts List for Installation of C4ISR Equipment	4-5

APPENDIX

Appendix	Title	Page
Appendix	Cable Schematic	A-1

CHAPTER 1

INTRODUCTION

Section I. SCOPE

1-1. This technical bulletin provides installation instructions for Command, Control, Communications, Computers, Intelligence, Surveillance, and Reconnaissance (C4ISR) equipment. The C4ISR equipment shall be installed in the following vehicles:

Truck, Utility, 2/4-Door: Heavy Variant, 1-1/4 Ton, 4x4, M1097A2

1-2. The information contained in this technical bulletin is the official authorization to perform the installation of the C4ISR equipment at the direct support maintenance level through contract maintenance teams.

Section II. NOTES

2-1. This technical bulletin is not an authorization for requisition or turn-in of vehicles.

2-2. This technical bulletin does not establish quantity or types of vehicles assigned to using units.

Section III. GENERAL INFORMATION

3-1. Included in the C4ISR equipment are:

- a. Single Channel Ground and Airborne Radio System (SINCGARS), AN/VRC-92F
- b. Force XXI Battle Command, Brigade-and-Below (FBCB2), AN/UYK-128 (V)4
- c. Precision Lightweight Global Positioning System Receiver (PLGR), AN/PSN-11
- d. Enhanced Position Location Reporting System (EPLRS), AN/VSQ-2 (V)
- e. Remote Rekey Device, KOK-13
- f. Quick-Erect Antenna Mount (QEAM), AB-1386/U
- g. Network Manager and Printer
- h. Supplementary Batteries

3-2. The C4ISR equipment becomes operable when all the components are installed in the vehicle and correct power is supplied.

Section IV. MAINTENANCE FORMS, RECORDS, AND REPORTS

Use the following to report any discrepancies:

- a. Reports of Maintenance and Unsatisfactory Equipment. See chapter 4, sections VI through VIII for information.
- b. Reports of Packaging and Handling Deficiencies. See chapter 4, sections VI through VIII for information.

Section V. CONSOLIDATED INDEX OF ARMY PUBLICATIONS

Refer to the latest issue of DA PAM 25-30 to determine whether there are new changes or additional publications pertaining to the C4ISR equipment.

CHAPTER 2

PURPOSE OF INSTALLATION

The purpose of installing the C4ISR equipment is to provide the primary means of integrating command and control capability.

CHAPTER 3

COMPLETION TIME FOR INSTALLATION

A total of 20 man hours are required for two personnel to install the C4ISR equipment. Typical vehicle downtime is 12 hours.

CHAPTER 4

PREPARATION FOR INSTALLATION

Section I. PREPARATION OF VEHICLE

Ensure that the site includes adequate lighting and a power source when drilling is required. Inspect the vehicle for damage that could affect installation. Have any such damage repaired before installing the C4ISR equipment.

Section II. ITEMS TO BE REMOVED

- 2-1.** Remove batteries. (Refer to TM 9-2320-280-20.)
- 2-2.** Remove left- and right-hand rear door, as applicable. (Refer to TM 9-2320-280-20.)
- 2-3.** Remove center tunnel insulation, as applicable. (Refer to TM 9-2320-280-20.)
- 2-4.** Remove standard radio rack. (Refer to TM 9-2320-280-20.)

Section III. LIST OF ITEMS TO BE RETAINED

- 3-1.** Batteries.
- 3-2.** Left- and right-hand rear cab enclosure panel (if applicable).
- 3-3.** Left- and right-hand rear fixed door (if applicable).

Section IV. PREPARATION OF C4ISR EQUIPMENT

Unpack, inspect, and check inventory.

Section V. PRECAUTIONS DURING HANDLING

Observe the following precautions to prevent equipment damage.

- a. Keep dust covers in place on connectors.
- b. Do not disassemble or modify parts in the C4ISR equipment unless authorized to do so.
- c. Keep mounting hardware covered and protected until needed.

Section VI. UNPACK AND INSPECT EQUIPMENT

- 6-1.** Unpack and inspect packaging for evidence of damage.
- 6-2.** Report any shipping damage on SF 364 Report of Discrepancy (ROD) as prescribed in AR 735-11-2/DLAR 4140.55/NAVMATINST 4355.73A/AFR 400-64/MCO 4430.F.

Section VII. INVENTORY C4ISR EQUIPMENT

If any item is missing, fill out and forward Transportation Discrepancy Report (TDR) (SF 361) as described in AR 55-38/NAVSUPINST 4610.33C/AFR 75-18/MCO P4610.19D/DLAR 450015.

Section VIII. EXAMINE EACH ITEM FOR DAMAGE

If any item is damaged, fill out and forward SF 364 Report of Discrepancy (ROD) as prescribed in AR 735-11-2/DLAR 4140.55/NAVMATINST 4355.73A/AFR 400-64/MCO 4430.F. All damages should be reported as prescribed by DA PAM 738-750, as contained in the Maintenance Management Update.

Section IX. C4ISR EQUIPMENT, DISTRIBUTION, AND CONSUMABLES

- 9-1. Items supplied in C4ISR equipment and/or required for installation.
- 9-2. Use table 4-1 to identify and inventory C4ISR equipment parts required to perform installation. Refer to table 4-2 to identify additional materials required to install C4ISR equipment.

Section X. DISTRIBUTION AND ISSUE INSTRUCTIONS

- 10-1. U.S. Forces: Do not requisition C4ISR equipment. It will be shipped automatically.
- 10-2. U.S. Army Depots: Requisition C4ISR equipment through supply channels.
- 10-3. Multiservice: Instructions shall be included for multiservice modifications.
- 10-4. MAP/MAS countries: Instructions shall be provided for MAP/MAS countries.

Section XI. PARTS LIST

KITS REQUIRED FOR THIS INSTALLATION:

NOTE

- Not all material in kits is required for this installation. Material not used during installation will be returned to stock for disposition in accordance with AR 725-50.
- If maintenance is to be performed on a vehicle with an existing kit, do not order entire kit for necessary reinstallation.

SINGARS:

- (A): MK-2326
- (B): MK-2327
- (C): MK-2328

REMOTE REKEY DEVICE:

(H): No kits available

QEAM:

(I): No kits available

PLGR:

(D): 57K4400

NETWORK MANAGER AND PRINTER:

(J): No kits available

EPLRS:

- (E): MK-2467A/VSQ-1
- (F): MK-2520/VSQ-1

SUPPLEMENTAL BATTERIES:

(K): No kits available

FBCB2:

(G): No kits available

MATERIAL REQUIRED FROM KITS:

Table 4-1. Kit Parts List for Installation of CAISR Equipment.

ITEM NO.	NOMENCLATURE	PART NUMBER	NATIONAL/NATO STOCK NUMBER	KIT	QTY.
1.	Bracket, Antenna	A3014546-1	5340-01-391-2742	(A),(B),(C)	2
2.	Bracket, Double-Angle	A3046237	5340-01-262-9566	(B),(C)	2
3.	Cable Assembly, Antenna	A3014031-17	5995-01-225-1660	(B),(C)	1
4.	Cable Assembly, Antenna, EPLRS	SM-C-911480	5995-01-167-1269	(E),(F)	2
5.	Cable Assembly, Power, Electrical	A3014040-9	5995-01-300-9324	(B),(C)	1
6.	Cable Assembly, Power, EPLRS	A3004939	5995-01-198-0538	(E),(F)	2
7.	Cable Assembly, Radio Frequency	A3014031-8	5995-01-219-7035	(A),(B),(C)	1
8.	Cable Assembly, Radio Frequency	A3014032-3	5995-01-219-7025	(A),(B),(C)	1
9.	Cable Assembly, Special Purpose	A3014038-12	5995-01-259-9283	(B),(C)	1
10.	Clamp, Loop	MS21333-67	5340-00-079-7837	(D)	1
11.	Clamp, Loop	MS21333-71	5340-00-057-2904	(A),(B),(C)	16
12.	Clamp, Loop	MS21333-75	5340-00-050-2740	(A),(B),(C)	11
13.	Clamp, Loop	MS21333-96	5340-00-088-1255	(C),(D)	2
14.	Clamp, Loop	MS21333-102	5340-00-984-8540	(B)	2
15.	Fiber Rope Assembly, Single Leg	A3167672-1	4020-01-341-8795	(A),(B),(C),(F)	2
16.	Gasket	A3013655-1	5330-01-205-2864	(A),(B),(C)	4
17.	Grommet, Nonmetallic	MS21266-4N	5325-00-923-9512	(B),(C)	2
18.	Grommet	MS35489-31	5325-00-174-9336	(D)	1
19.	Handset	H-250/U	5965-00-043-3463	(A),(B),(C),(F)	2
20.	Insert	12446871-2	5310-01-411-3422	(C)	3
21.	Loudspeaker	A3014065-1	5965-01-222-1420	(A),(B),(C)	2
22.	Mounting Base, Electrical Equipment	A3013367-1	5975-01-188-8873	(A),(B),(C),(F)	1
23.	Mounting Base, Electrical Equipment	A3014053-1	5975-01-235-1962	(B),(C)	1
24.	Nut	MS35650-302	5310-00-934-9751	(A),(B),(C),(E),(F)	23
25.	Nut	MS51967-2	5310-00-761-6882	(A),(B),(C),(E),(F)	36
26.	Nut	MS51967-5	5310-00-880-7744	(F)	40
27.	Nut	MS51967-6	5310-00-931-8167	(E),(F)	8
28.	Nut	MS51967-8	5310-00-732-0558	(E),(F)	2
29.	Nut	MS51968-5	5310-00-880-7746	(A),(B),(C),(F)	2
30.	Nut	9419143	5310-01-148-0240	(C)	11
31.	Nut	MS35690-610	5310-00-655-6457	(F)	26
32.	Nut, Strip	A3014064-1	N/A	(B),(C)	1
33.	Plate, Backing	A3046222	5975-01-264-1720	(F)	2
34.	Plate, Metal	A3103740	5340-01-302-0068	(F)	2

MATERIAL REQUIRED FROM KITS (Contd):

Table 4-1. Kit Parts List for Installation of C4ISR Equipment (Contd).

ITEM NO.	NOMENCLATURE	PART NUMBER	NATIONAL/NATO STOCK NUMBER	KIT	QTY.
35.	Plate, Metal	A3103784	N/A	(F)	2
36.	Plate, Mounting	A3014550-1	N/A	(A),(B),(C)	2
37.	Screw, Cap	B1821BH025C100N	5305-00-225-3843	(C)	17
38.	Screw, Cap	B1821BH025C125N	5305-00-068-0509	(C),(D)	8
39.	Screw, Cap	B1821BH025C175N	5305-00-071-2510	(D)	1
40.	Screw, Cap	MS35207-261	5305-00-990-6444	(D)	1
41.	Screw, Cap	MS35307-365	5305-00-847-1159	(A),(B),(C),(F)	11
42.	Screw, Cap	MS90725-6	5305-00-068-0502	(A),(B),(F)	19
43.	Screw, Cap	MS90725-8	5305-00-225-3839	(A),(B),(C),(F)	39
44.	Screw, Cap	MS90725-10	5305-00-068-0509	(F)	6
45.	Screw, Cap	MS90726-36	5305-00-225-9091	(B),(C)	22
46.	Screw, Cap	MS90725-30	5306-00-225-8495	(F)	8
47.	Screw, Cap	MS90725-62	5305-00-269-3213	(F)	8
48.	Screw, Cap	MS90725-64	5305-00-325-8387	(F)	18
49.	Screw, Machine	MS35224-65	5310-00-543-5743	(F)	1
50.	Screw, Machine	MS35206-217	5305-00-889-2999	(E),(F)	8
51.	Screw, Machine	MS35190-291	5305-00-958-5247	(B)	2
52.	Screw, Machine	MS35206-263	5305-00-984-6210	(C)	4
53.	Screw, Machine	MS35207-261	5305-00-990-6444	(C)	1
54.	Screw, Machine	MS35207-263	5305-00-989-7434	(E),(F)	12
55.	Screw, Machine	MS35207-267	5305-00-993-1851	(F)	12
56.	Screw, Self-Tapping	9421073	5305-01-162-8512	(C)	14
57.	Screw, Self-Tapping	9416639	5305-01-197-2320	(D)	1
58.	Strap, Tie	MS3367-1-0	5975-00-984-6582	(C),(D)	3
59.	Support, Antenna	A3103782	5985-01-312-3028	(F)	2
60.	Washer	MS15795-814	5310-00-773-7618	(F)	26
61.	Washer	MS27183-10	5310-00-809-4058	(B),(C),(F)	41
62.	Washer	MS27183-12	5310-00-081-4219	(B),(C),(F)	30
63.	Washer	MS27183-18	5310-00-809-5998	(B),(C),(F)	5
64.	Washer	2436161	5310-01-102-3270	(C),(D)	29
65.	Washer	MS27183-8	5310-00-809-8546	(E),(F)	34
66.	Washer, Lock	MS35333-76	5310-00-180-0277	(C)	6
67.	Washer, Lock	MS35338-43	5310-00-045-3296	(A),(B),(C),(D),(E),(F)	21
68.	Washer, Lock	MS35338-44	5310-00-582-5965	(A),(B),(C),(D),(F)	43
69.	Washer, Lock	MS35338-45	5310-00-407-9566	(B),(C)	24
70.	Washer, Lock	MS35338-46	5310-00-637-9541	(B),(C),(E),(F)	10
71.	Washer, Lock	MS35338-48	5310-00-584-5272	(B),(C)	2
72.	Washer, Lock	MS35338-141	5310-00-984-7042	(F)	26
73.	Washer, Lock	MS45904-60	5310-00-080-9786	(E)	17
74.	Washer, Lock	MS45904-68	5310-00-889-2528	(A),(B),(C)	51
75.	Washer, Lock	MS45904-72	5310-00-889-2527	(A),(B),(C),(E),(F)	68

MATERIAL REQUIRED BUT NOT INCLUDED IN KITS:*Table 4-2. Non-Kit Parts List for Installation of C4ISR Equipment.*

ITEM NO.	NOMENCLATURE	PART NUMBER	NSN	QTY.
1.	AC Distribution Box	A3265676	N/A	1
2.	AC Output Selection Box	A3265686	N/A	1
3.	Antenna	A3005031	5820-01-183-9462	2
4.	Antenna AS-3900/VRC	A3017889-2	5985-01-308-8988	2
5.	Antenna, Element (lower)	A3018230-1	5985-01-201-1498	2
6.	Antenna, Element (upper)	A3017901-2	5985-01-306-4622	2
7.	Antenna, PLGR	AT575-030	5985-01-375-4660	1
8.	Assembly, Display Lock	872843-01	N/A	1
9.	Base, Lower	A3265624	N/A	1
10.	Base, Upper	A3265626	N/A	1
11.	Battery	8A27M	6140-01-524-2650	1
12.	Battery Alarm Box	A3265665	6350-01-523-7612	1
13.	Battery Box	A3265709	N/A	1
14.	Battery Tray	A3265708	N/A	1
15.	Bolt	MS35751-18	5306-00-108-9988	4
16.	Bolt, Carriage	93548A652	5306-01-527-3738	2
17.	Bracket, PLGR	986-0645-001	5975-01-375-1302	1
18.	Bracket, PLGR Antenna	A3210768	5985-01-477-9907	1
19.	Bracket, User Readout (URO)	A3006206-2	5340-01-386-7841	2
20.	Cable Assembly, Battery Alarm Box	A3265596	N/A	1
21.	Cable Assembly, Battery Negative	A3265734	N/A	1
22.	Cable Assembly, Battery Positive	A3265733	N/A	1
23.	Cable Assembly, Ethernet	A3265597	N/A	1
24.	Cable Assembly, Ethernet	A3265725	N/A	1
25.	Cable Assembly, Inverter Negative	A3265692	N/A	1
26.	Cable Assembly, Inverter Positive	A3265730	N/A	1
27.	Cable Assembly, KOK-13 Power	A3265651	6150-01-522-4040	1
28.	Cable Assembly, Output Power Selection Box	A3265726	N/A	1
29.	Cable Assembly, PCMCIA	A3265957	5995-01-522-4436	1
30.	Cable Assembly, Power, PLGR	9728558-10	6150-01-375-8661	1
31.	Cable Assembly, EPLRS Antenna	A3265727	N/A	1
32.	Cable Assembly, External Power	A3265729	N/A	1
33.	Cable Assembly, Power	A3014039-2	5995-01-219-1843	1
34.	Cable Assembly, Power	A3279383-3	5995-01-453-9171	1
35.	Cable Assembly, Power	426-0141-050	6150-01-375-8662	1
36.	Cable Assembly, Printer AC Power	A3265673	6150-01-522-4044	1
37.	Cable Assembly, Prosine Inverter Output	A3265674	6150-01-522-5603	1
38.	Cable Assembly, Special Purpose	A3014038-3	5995-01-219-4704	1
39.	Cable Assembly, Special Purpose	A3014037-4	5995-01-335-7863	1

MATERIAL REQUIRED BUT NOT INCLUDED IN KITS (Contd):

Table 4-2. Non-Kit Parts List for Installation of C4ISR Equipment (Contd).

ITEM NO.	NOMENCLATURE	PART NUMBER	NSN	QTY.
40.	Cable Assembly, Special Purpose	A3005328	5995-01-375-2439	2
41.	Cable Block	7565K51	N/A	1
42.	Cable Carrier	55835K42	N/A	1
43.	Cable Carrier	55835K44	N/A	1
43.1	Cable, W1	866003-3	5995-01-478-4908	1
43.2	Cable, W2	881327-1	5995-01-478-4876	1
43.3	Cable, W3N	881336-1	5995-01-478-4913	1
43.4	Cable, W3P	881335-1	5995-01-478-4891	1
44.	Center Support	A3265621	N/A	1
45.	Channel Hold Down	A3265712	5340-01-527-4884	1
46.	Clamp, Loop	MS21333-69	5340-00-764-7051	27
47.	Clamp, Loop	MS21333-65	5340-00-905-0790	7
48.	Clamp, Loop	3225T43	N/A	5
49.	Clamp, Loop	3225T44	N/A	2
50.	Clamp, Loop	3225T46	N/A	14
51.	Clamp, Loop	3225T48	N/A	12
52.	Clamp, Subassembly	A3209994	5340-01-424-1516	4
53.	Computer Stand Assembly	A3265632	N/A	1
54.	CPU (Central Processing Unit)	881292-1	7021-01-474-3793	1
55.	DC Charger	93-WP40-A	6130-01-526-2770	1
56.	DC Charger Guard	A3265713	N/A	1
57.	DC-DC Adapter	PA1540-647	6130-01-524-2337	1
58.	Decal	861868-2	N/A	1
58.1	Device, Serial Interface Adapter	881331-1	4920-01-478-3722	1
59.	Display	881293-1	7025-01-475-0229	1
60.	External Power Reception Box	A3265660	6110-01-523-7686	1
61.	Fender Washer	9109A111	N/A	13
62.	Fender Washer	90313A112	5310-01-527-4877	4
63.	Fender Washer	6001001	5310-01-498-7962	4
64.	Grommet, Nonmetallic	MS21266-4N	5325-00-923-9512	A/R
65.	Grommet, Nonmetallic	12338098	5325-01-308-5424	2
66.	Guard, Amp	872842-1	5935-01-487-2172	1
67.	Insert	12446871-2	5310-01-411-3422	18
68.	Insert	ALS4-420-165	5310-01-411-3422	14
69.	Inverter	806-1050	6130-01-527-4041	1
70.	Inverter Front Cover Plate	A3265693	N/A	1
71.	Inverter Housing Support	A3265690	N/A	1
72.	Inverter Top Plate	A3265691	N/A	1
73.	Isolation Kit, CPU	872826-2	5340-01-481-5741	1
74.	Isolation Kit, Display	872870-1	5340-01-481-5757	1

MATERIAL REQUIRED BUT NOT INCLUDED IN KITS (Contd):*Table 4-2. Non-Kit Parts List for Installation of C4ISR Equipment (Contd).*

ITEM NO.	NOMENCLATURE	PART NUMBER	NSN	QTY.
75.	KOK-13 Mount	A3265652	N/A	1
76.	Lanyard	8925T5-7X19	4010-01-497-2675	1
77.	Master Kill Switch Box	A3265670	5930-01-523-5970	1
78.	Mount, Ramball	RAM-D-111U	5975-01-485-3615	1
79.	Mount, Resilient	MT-6146/VSQ-1	5340-01-167-8297	2
80.	Mounting Frame	A3265612	N/A	1
81.	Nut	90675A005	5310-01-348-3570	12
82.	Nut	MS51967-9	5310-00-761-0654	1
83.	Nut	MS35649-2382	5310-00-056-3395	2
84.	Nut	13218E0320-293	5310-00-913-8881	8
85.	Nut	9417954	5310-00-931-8167	8
86.	Nut	MS35649-2252	5310-00-997-1888	3
87.	Nut	9418892	5310-01-157-9819	6
88.	Nut, Self-Locking	MS17829-5C	5310-00-245-3424	4
89.	Offset Mount	A3046219	5985-01-244-9836	21
90.	Plate, Frame Mounting	A3265610	N/A	1
91.	Printer Assembly	A3265640	N/A	1
92.	Rack, QEAM	A3265715	N/A	1
93.	Screw	MS24671-43	5305-01-056-3510	4
94.	Screw	MS51959-15	5305-00-770-2579	4
95.	Screw	93195A1113	N/A	4
96.	Screw	90087A829	N/A	2
97.	Screw	90087A836	N/A	2
98.	Screw	MS90725-36	5306-01-075-8519	12
99.	Screw	MS90725-123	5305-00-071-1776	2
100.	Screw	MS90725-125	5305-00-071-1778	3
101.	Screw	MS90728-6	5305-00-068-0508	2
102.	Screw	MS90728-8	5305-00-225-3843	3
103.	Screw	MS90726-62	5305-00-269-2805	6
104.	Screw	8599267-531	5305-00-847-1159	4
105.	Screw, Cap	B1821BH031C125N	2306-00-226-4829	4
106.	Screw, Cap	B1821BH031F100N	5305-00-051-4076	2
107.	Screw, Cap	B1821BH031F125N	5305-00-051-4078	10
108.	Screw, Cap	B1821BH038C150N	5305-00-725-2317	1
109.	Screw, Cap	B1821AH038C225N	5305-01-434-2947	2
110.	Screw, Cap	B1821BH031C100N	5306-00-226-4827	8
111.	Screw, Cap	B1821BH031F075N	5306-00-050-1238	2
112.	Screw, Cap	B1821BH031C300N	5306-00-226-4837	4
113.	Screw, Machine	MS35207-265	5305-00-993-1848	4
114.	Screw, Machine	MS35207-268	5305-00-995-3442	8

MATERIAL REQUIRED BUT NOT INCLUDED IN KITS (Contd):

Table 4-2. Non-Kit Parts List for Installation of C4ISR Equipment (Contd).

ITEM NO.	NOMENCLATURE	PART NUMBER	NSN	QTY.
115.	Screw, Machine, Tapping	9421073	5305-01-162-8512	45
116.	Screw, Self-Tapping	9426241	5305-01-206-7219	1
117.	Shelf, Electrical Equipment	A3046236	5975-01-262-9575	2
118.	Shunt Assembly	PKMM-000-013	N/A	1
119.	Spacer	10705AL315C	5365-01-487-3145	4
120.	Spacer	92510A318	N/A	10
121.	Spacer Plate	A3265625	N/A	1
122.	Spacer Plate (bottom)	A3265609	N/A	2
123.	Spacer Plate (top)	A3265611	N/A	2
124.	Strap	3051T42	N/A	2
125.	Strap, Ground	4801C3SG02	5340-01-311-0870	4
126.	Strap, Ground	10208-3506-01	N/A	A/R
127.	Strap, Tie	MS3367-1-0	5975-00-984-6582	A/R
128.	Support, Radio Rack	A3046235	5342-01-262-9563	2
129.	Terminal Strip	7527K26	5940-01-449-3119	1
130.	Terminal Strip	7527K28	N/A	1
131.	Terminal Lug	CRS-DY-1406	N/A	7
132.	Terminal Lug	CRS-DY-1010	5940-01-514-1849	6
133.	Terminal Lug	CRS-DY-1810	5940-01-143-4771	9
134.	Terminal Lug	CRS-DY-1410	N/A	10
135.	Terminal Lug	MS20659-141	5940-00-113-9825	4
136.	Terminal Lug	MS20659-129	5940-00-114-1314	2
137.	Tubing, Shrink	MS23053/4-302-0	5970-01-161-6796	A/R
138.	Washer	MS51412-25	5310-00-044-6477	4
139.	Washer	MS15795-814	5310-00-773-7618	26
140.	Washer	2436162	5310-01-119-1024	8
141.	Washer	2436163	5310-01-412-4013	16
142.	Washer	MS27183-14	5310-00-080-6004	8
143.	Washer	120393	5310-00-012-0393	8
144.	Wingnut	MS51553-420	5310-01-384-2546	4
145.	Wingnut	MS35425-75	5310-01-078-5996	1
146.	Wire, Braided	AA59569F30T0375	6145-00-191-8402	A/R
147.	Wire, Lock	MS20995C32	9505-00-293-4208	A/R

CHAPTER 5

INSTALLATION PROCEDURES

Section I. SCOPE

This chapter provides instructions for installation of C4ISR items in the vehicle. When installing C4ISR equipment, be sure to read and follow instructions and illustrations carefully.

Section II. BATTERY BOX PREPARATIONS

- 2-1. Using battery tray as template, locate, mark, and drill four 0.266-in. diameter holes (1) in battery box (2).

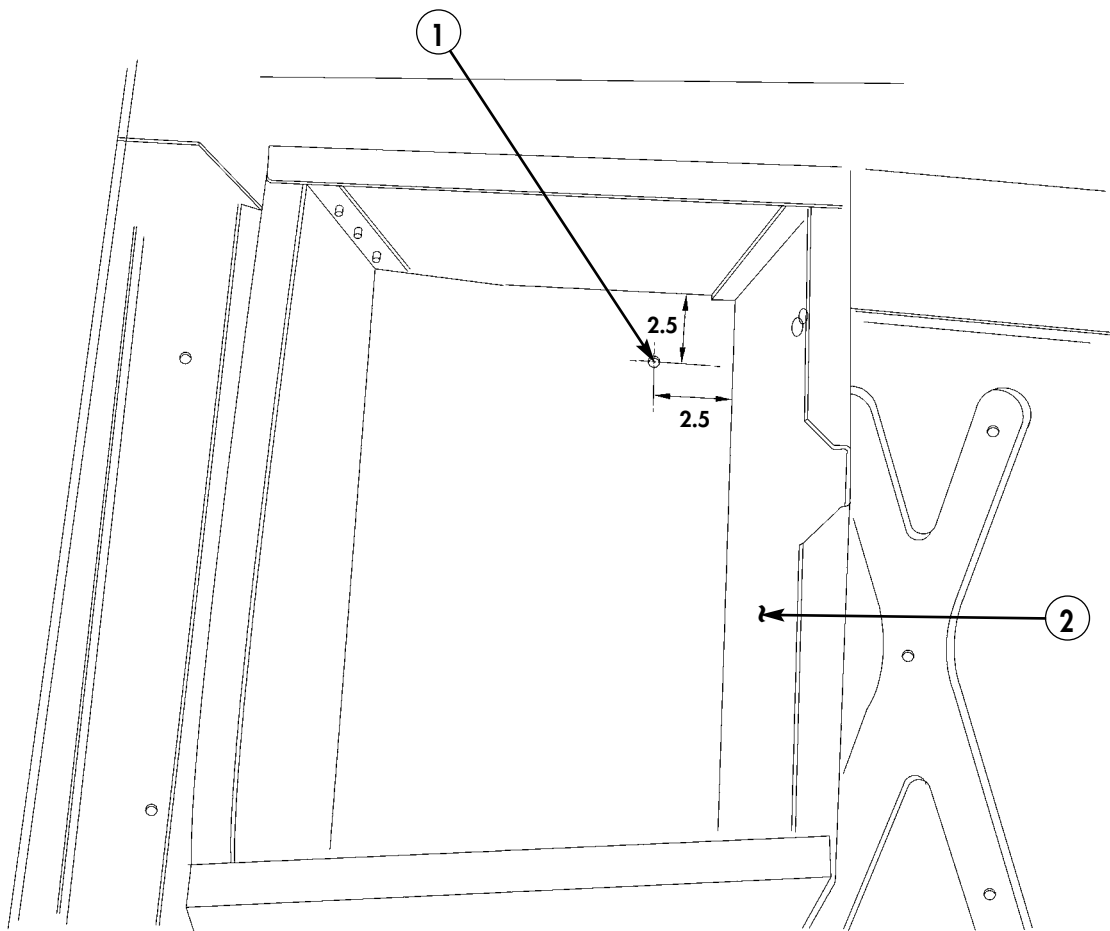

Figure 5-1.

- 2-2. Locate, mark, and drill three 0.156-in. diameter holes (3).
- 2-3. Locate, mark, and drill one 1.325-in. diameter hole (5) in cab enclosure panel (7).
- 2-4. Locate, mark, and drill one 1.125-in. diameter hole (4) in cab enclosure panel (7).
- 2-5. Install grommet material (6) in holes (4) and (5).

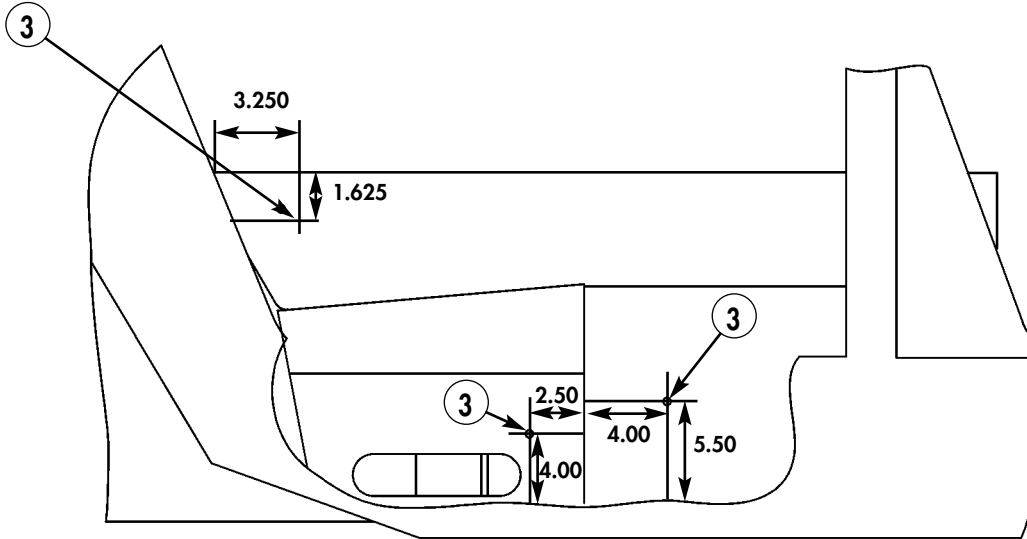
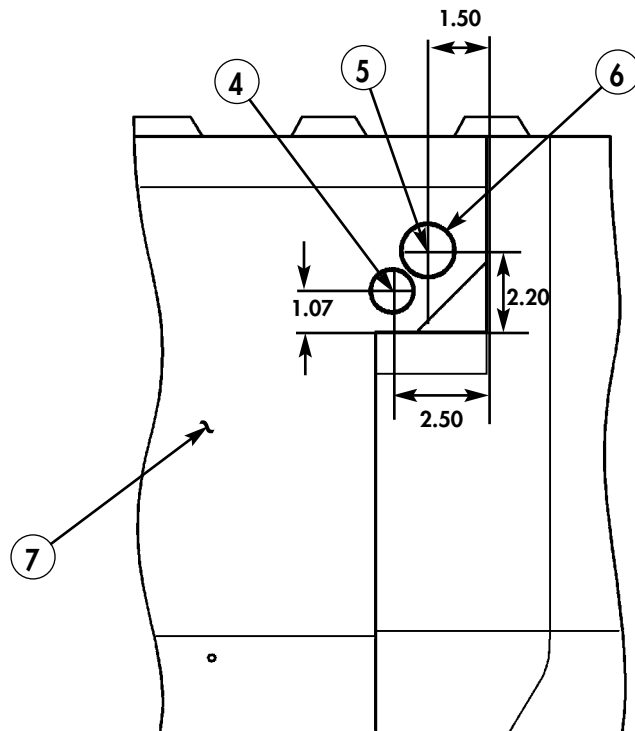

Figure 5-2.



6. GROMMET MATERIAL – MS21266-4N – QTY. A/R

Figure 5-3.

- 2-6. Locate, mark, and drill two 0.281-in. diameter holes (9) in rear battery box (2) forward wall.
- 2-7. Locate, mark, and drill one 1.125-in. diameter hole (8) in rear battery box (2) forward wall.
- 2-8. Install grommet material (6) in hole (8).

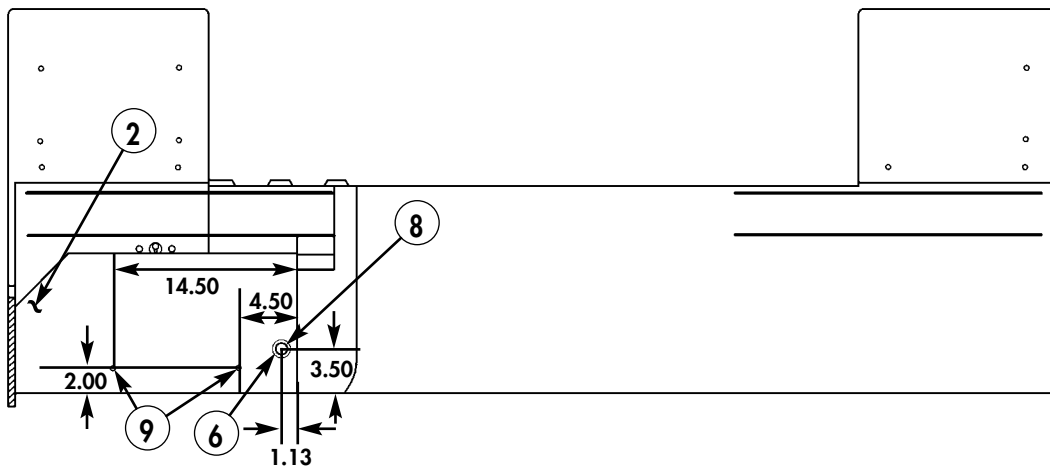

Figure 5-4.

- 2-9. Locate, mark, and drill one 0.281-in. diameter hole (10) in vehicle body rail (11).
- 2-10. Locate and mark area 1.00-in. x 6.00-in. (12) in vehicle body rail (11).
- 2-11. Remove metal in marked area (12). Smooth edges and paint exposed bare metal edges.

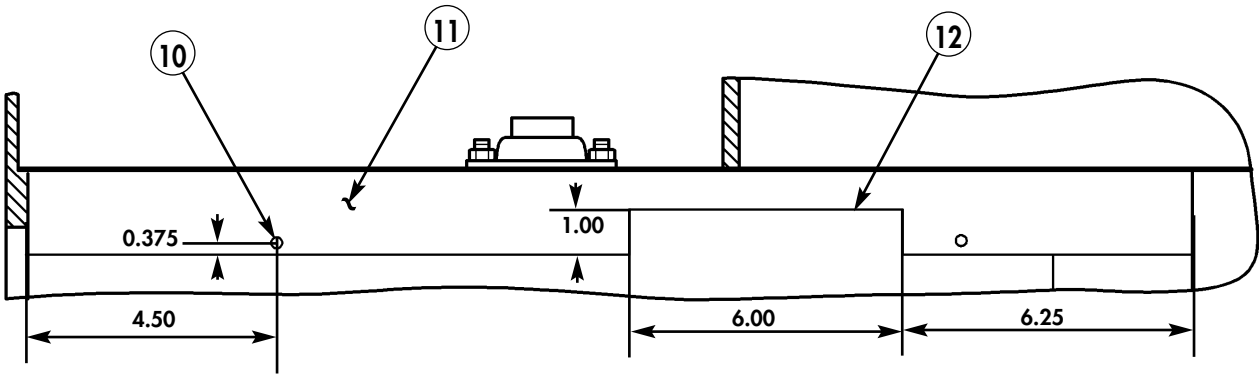
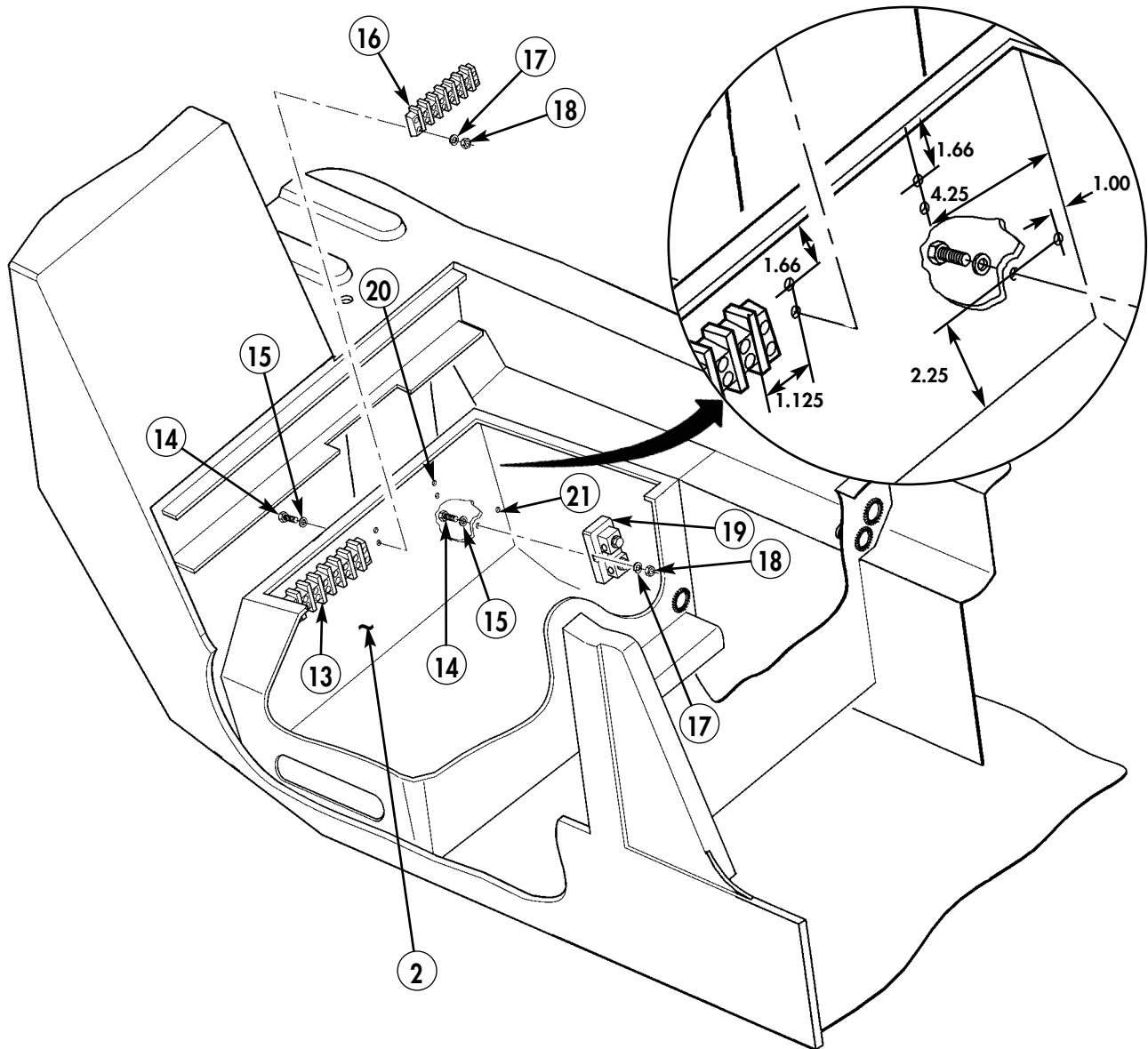

Figure 5-5.

- 2-12. Using terminal strips (16) and (13) as templates locate, mark, and drill eight 0.201-in. diameter holes (20) in battery box (2) rear wall.
- 2-13. Secure one 8-position terminal strip (13) and one 6-position terminal strip (16) to battery box (2) rear wall with eight bolts (14), washers (15), lockwashers (17), and nuts (18).
- 2-14. Using shunt assembly (19) as template, locate, mark, and drill two .201-in. diameter holes (21) in battery box (2) rear wall.
- 2-15. Secure shunt assembly (19) to battery box (2) rear wall with two bolts (14), two washers (15), two lockwashers (17), and two nuts (18).



- 13. TERMINAL STRIP (8-POLE) – 7527K28 – QTY. 1
- 14. SCREW – MS35207-267 – QTY. 10
- 15. WASHER – MS27183-8 – QTY. 10
- 16. TERMINAL STRIP (6-POLE) – 7527K26 – QTY. 1
- 17. LOCKWASHER – MS45904-60 – QTY. 10
- 18. NUT – MS35650-302 – QTY. 10
- 19. SHUNT ASSEMBLY – PKMM-000-013 – QTY. 1

Figure 5-6.

2-16. Locate, mark, and drill two 1.375-in. diameter cable access holes (22) in battery box (2) rear wall.

2-17. Install grommet material (6) in cable access holes (22).

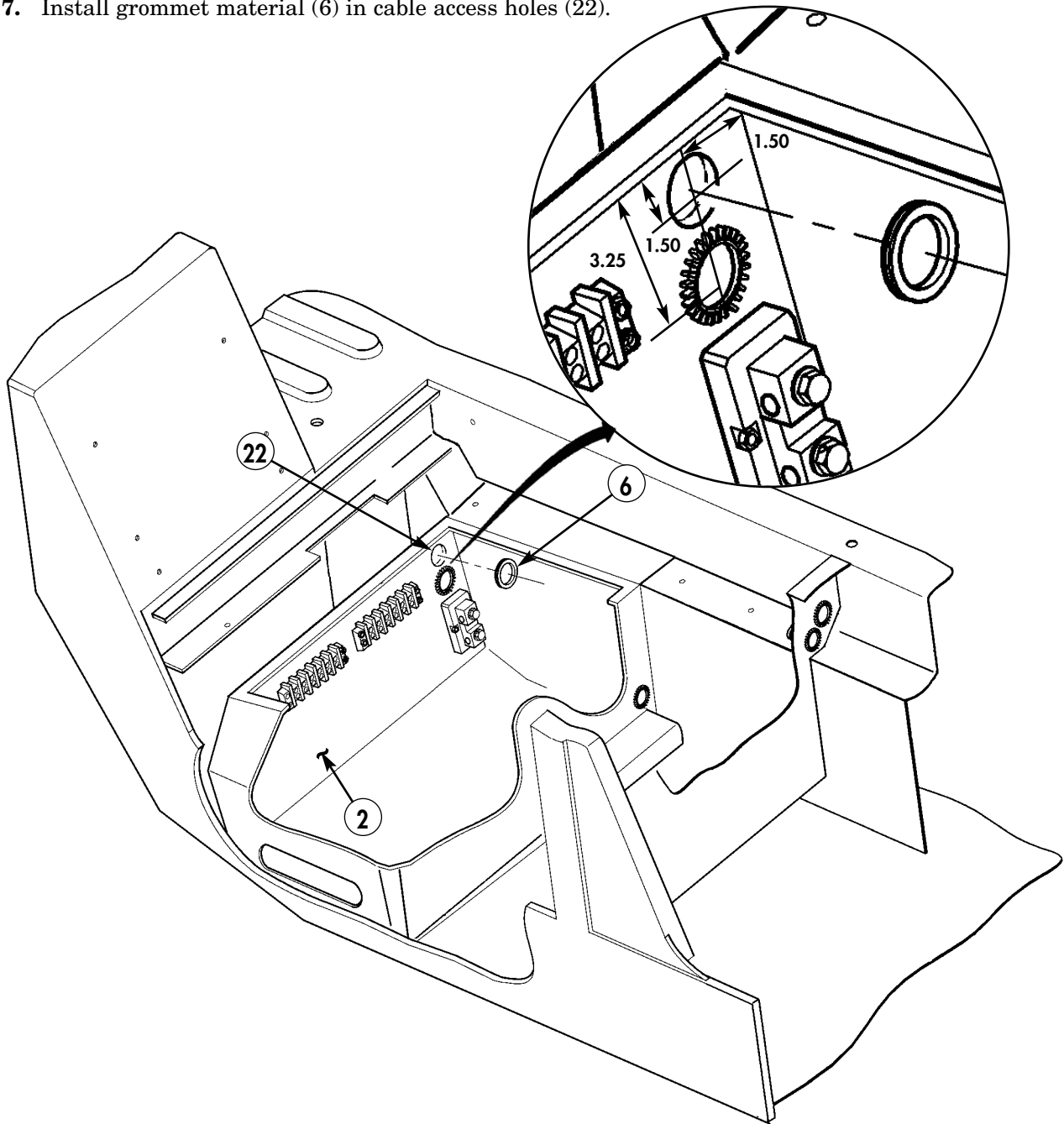

Figure 5-7.

Section III. INTEGRATED RACK INSTALLATION

- 3-1.** Remove two inserts (2) from bottom of integrated rack (1).

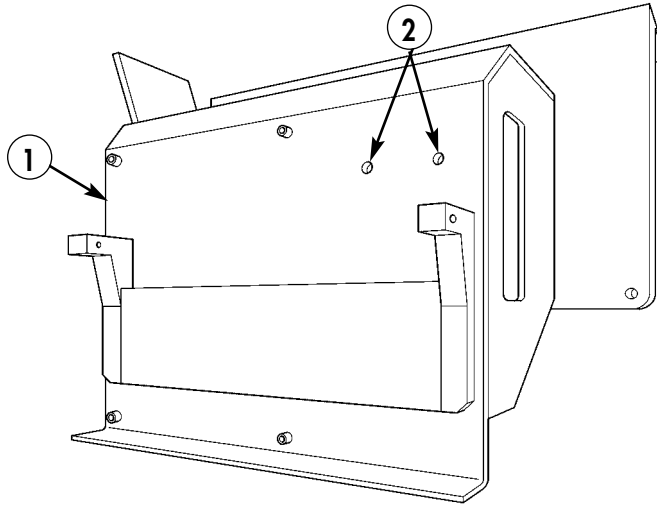
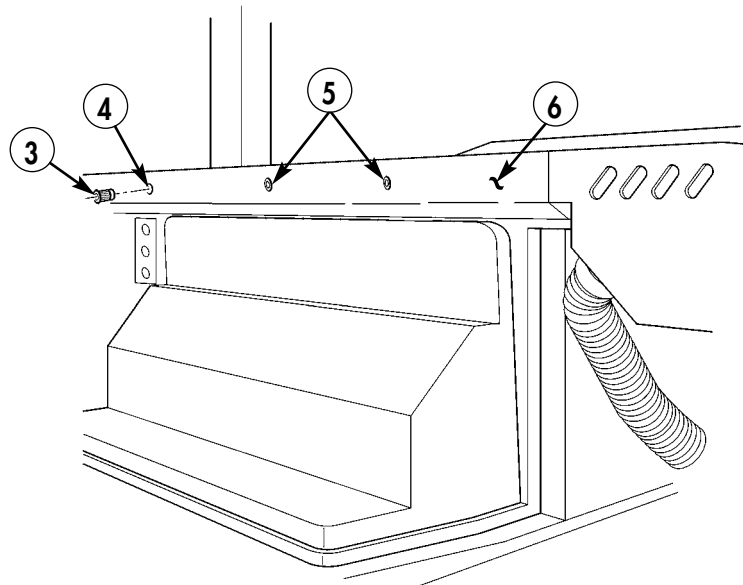

Figure 5-8.

- 3-2.** Using integrated rack (1) as template, locate, mark, and drill one 0.390-inch diameter hole (4) in dash (6).
- 3-3.** Remove paint from vicinity of hole (4) and two existing inserts (5).
- 3-4.** Install insert (3) in hole (4).
- 3-5.** Apply anti-seize compound to vicinity of inserts (3) and (5) as required.



- 3. INSERT - 12446871-2 - QTY. 1**

Figure 5-9.

- 3-6. Remove paint from vicinity of three mounting slots (7) on integrated rack (1).
- 3-7. Apply anti-seize compound to vicinity of three mounting slots (7) on integrated rack (1) as required.

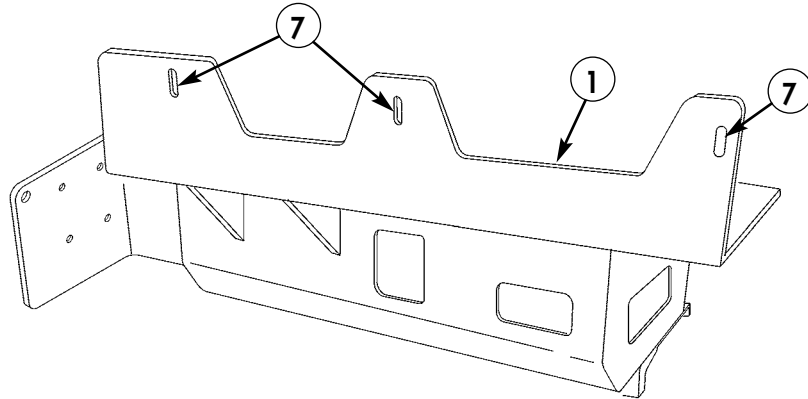
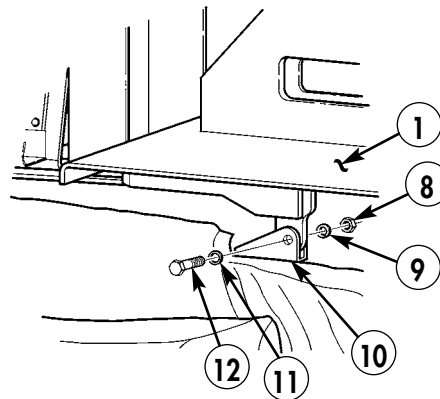

Figure 5-10.

NOTE

Do not install mounting hardware on top of integrated rack at this time. Not installing this hardware leaves the integrated rack free to pivot to assist in routing cabling. Secure rack only after all cabling has been routed.

- 3-8. Mount integrated rack (1) to existing radio rack mount (10) with capscrew (12), washer (11), lockwasher (9), and nut (8). Repeat for opposite side. Do not tighten capscrew (12).



- 8. NUT – MS35649-2382 – QTY. 2
- 9. LOCKWASHER – MS35338-46 – QTY. 2
- 11. WASHER – 2436163 – QTY. 2
- 12. CAPSCREW – B1821AH038C225N – QTY. 2

Figure 5-11.

Section IV. SINGARS MOUNTING TRAY AND AMP GUARD INSTALLATION

- 4-1. Remove paint from vicinity of four mounting holes (6) on integrated rack (7) and vicinity of four mounting holes (5) on bottom of mounting base (4).
- 4-2. Apply anti-seize compound to vicinity of four mounting holes (6) on integrated rack (7) and four mounting holes (5) on bottom of mounting base (4) as required.

NOTE

Two lockwashers and one nut are used on driver-side screws only.

- 4-3. Install mounting base (4) and amp guard (9) on integrated rack (7) with two capscrews (2), two capscrews (3), six lockwashers (1), and two nuts (8).
- 4-4. Place warning decal (10) on amp guard (9).

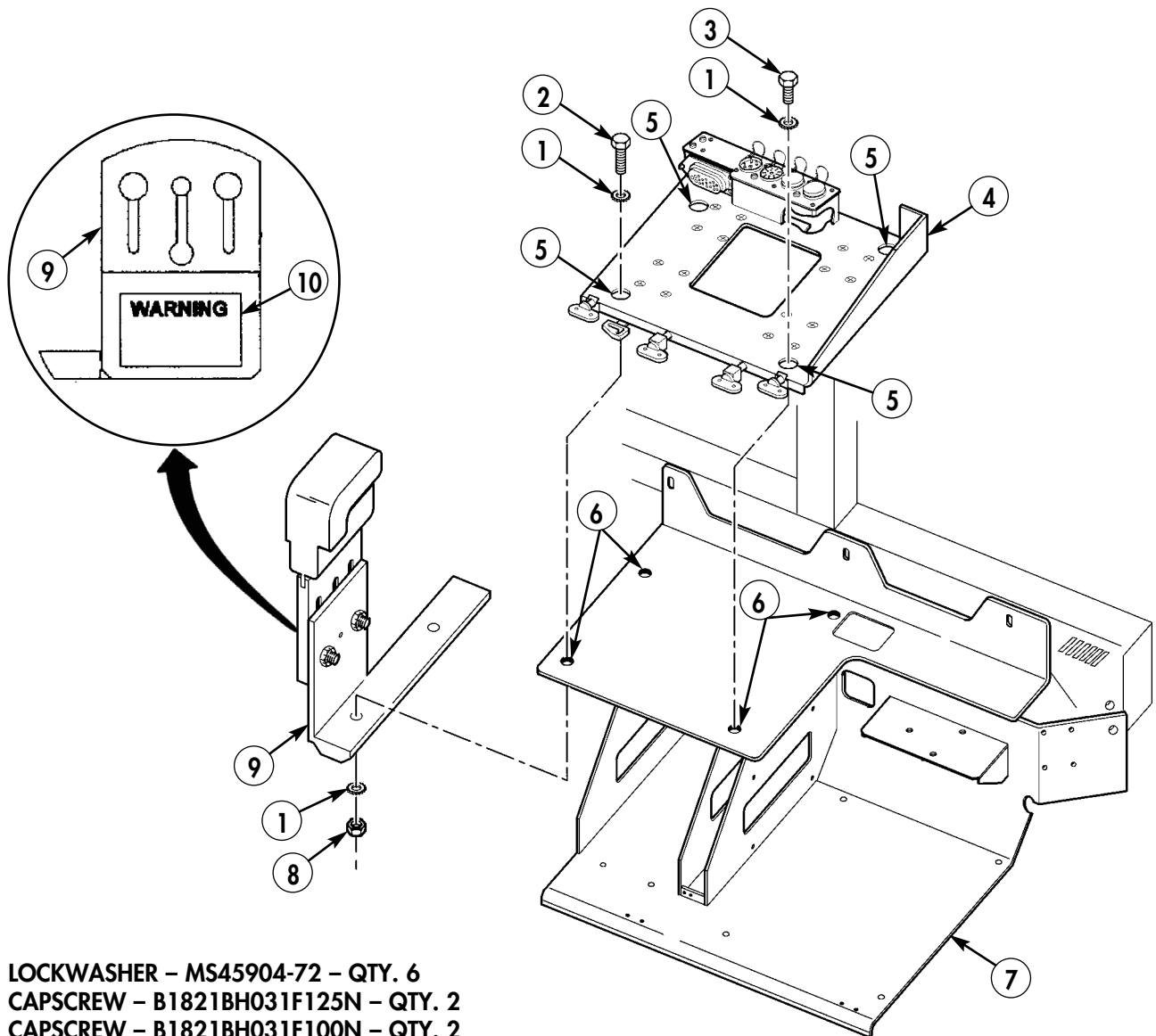

1. LOCKWASHER – MS45904-72 – QTY. 6
2. CAPSCREW – B1821BH031F125N – QTY. 2
3. CAPSCREW – B1821BH031F100N – QTY. 2
4. MOUNTING BASE, MT-6352/VRC – A3013367-1 – QTY. 1
8. NUT – MS51968-5 – QTY. 2
9. AMP GUARD – 872842-1 – QTY. 1
10. DECAL – 861868-2 – QTY. 1

Figure 5-12.

Section V. POWER AMPLIFIER INSTALLATION

- 5-1. Remove paint from vicinity of four mounting areas (2) on MT-6353/VRC mounting base (1) and apply anti-seize compound as required.

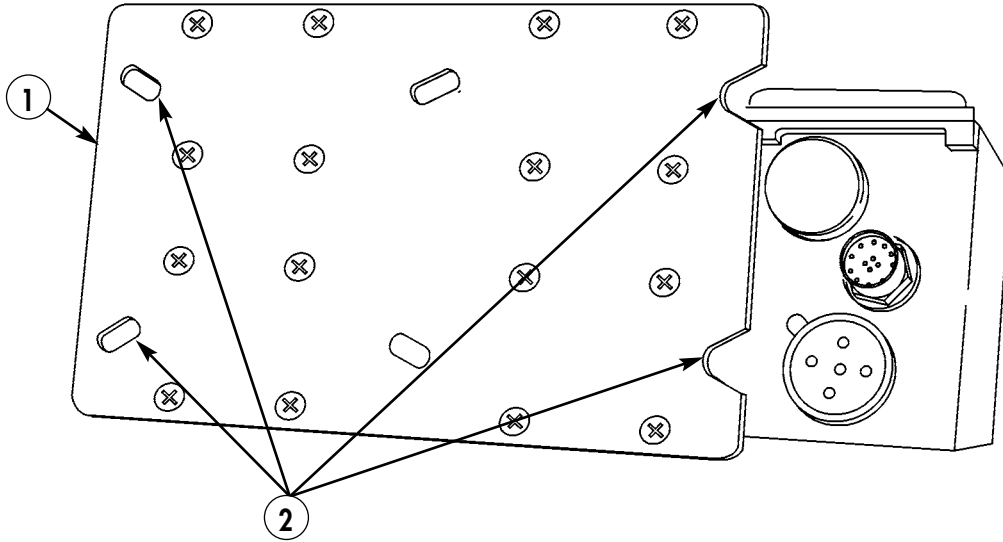

1. MOUNTING BASE, MT-6353/VRC – A3014053-1 – QTY. 1

Figure 5-13.

- 5-2. Remove paint from vicinity of four mounting holes (4) on integrated rack (3) and apply anti-seize compound as required.

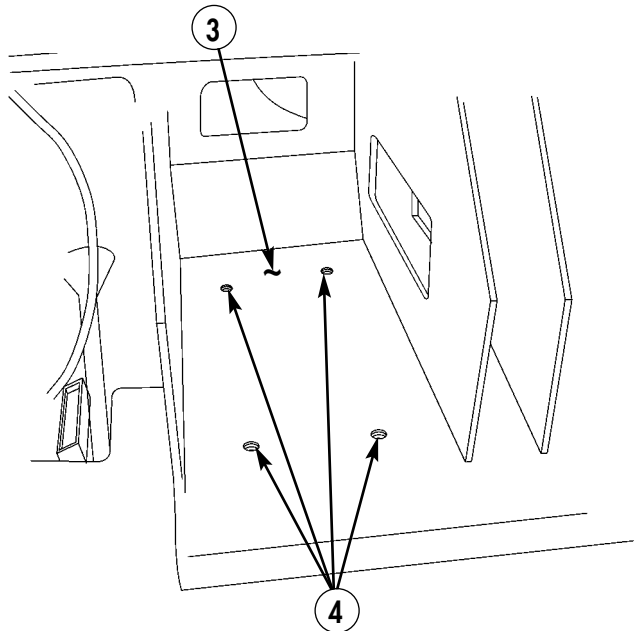
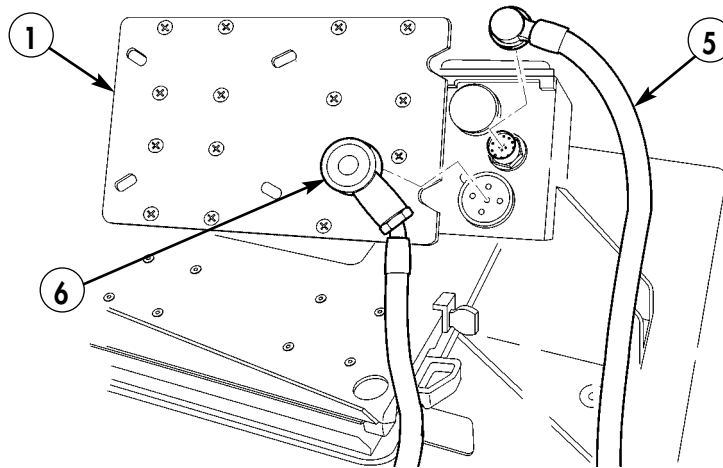

Figure 5-14.

- 5-3. Attach control cable (5) to MT-6353/VRC mounting base (1).
- 5-4. Attach power cable (6) to MT-6353/VRC mounting base (1).



- 5. CONTROL CABLE – A3014037-4 – QTY. 1
- 6. POWER CABLE – A3014040-9 – QTY. 1

Figure 5-15.

NOTE

Ensure control cable and power cable are routed through hole in back of integrated rack before installing MT-6353/VRC mounting base. Refer to chapter 5, section XXXI.

- 5-5. Attach MT-6353/VRC mounting base (1) to integrated rack (3) with two capscrews (9) and (10), four lockwashers (8), and nut strip (7).

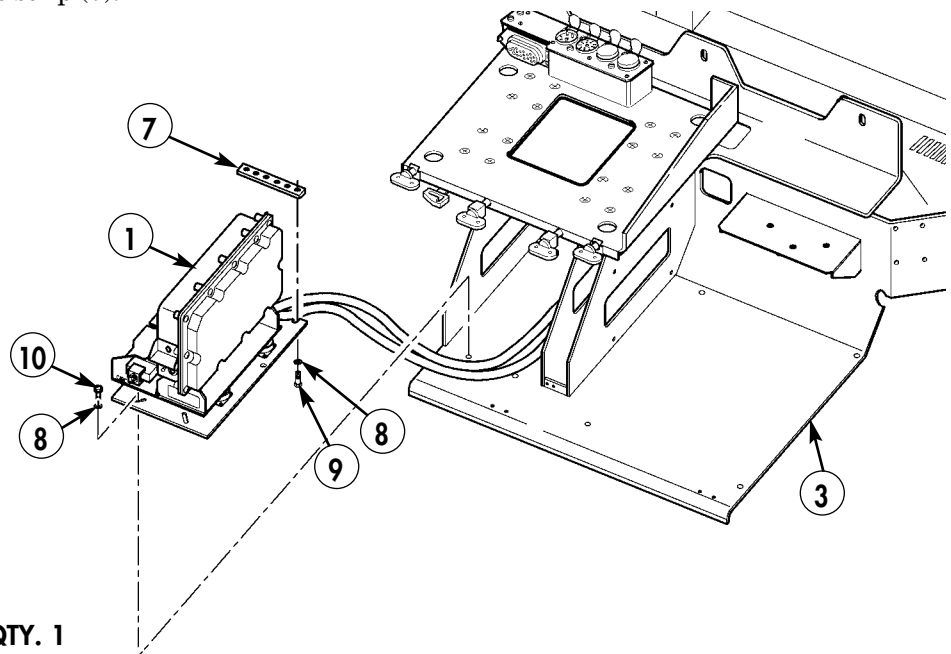

- 7. NUT STRIP – A3014064-1 – QTY. 1
- 8. LOCKWASHER – MS45904-72 – QTY. 4
- 9. CAPSCREW – B1821BH031F125N – QTY. 2
- 10. CAPSCREW – B1821BH031F075N – QTY. 2

Figure 5-16.

Section VI. FBCB2 COMPONENTS INSTALLATION

NOTE

SINCGARS model AN/VRC-92F shown.

- 6-1. Remove paint from vicinity of holes (8) on integrated rack (7) and on both sides from vicinity of corresponding holes (10) on CPU isolation kit (4). Apply anti-seize compound as required.
- 6-2. Install CPU isolation kit (4) on integrated rack (7) with three capscrews (3), washers (2), and lockwashers (1), leaving open holes (8) and (10).
- 6-3. Install keyboard (9) in keyboard slot of integrated rack (7).
- 6-4. Install CPU (6) on CPU isolation kit (4) with two existing fastener guards (5).
- 6-5. Fabricate ground strap (13) from 8.00-in. length of braided wire and two terminal lugs.
- 6-6. Install ground strap (13) on CPU ground stud (17) with existing washer (14), lockwasher (15), and wingnut (16).
- 6-7. Install ground strap (13) on CPU isolation kit (4) and integrated rack (7), with capscrew (11), washer (2), and two lockwashers (12).

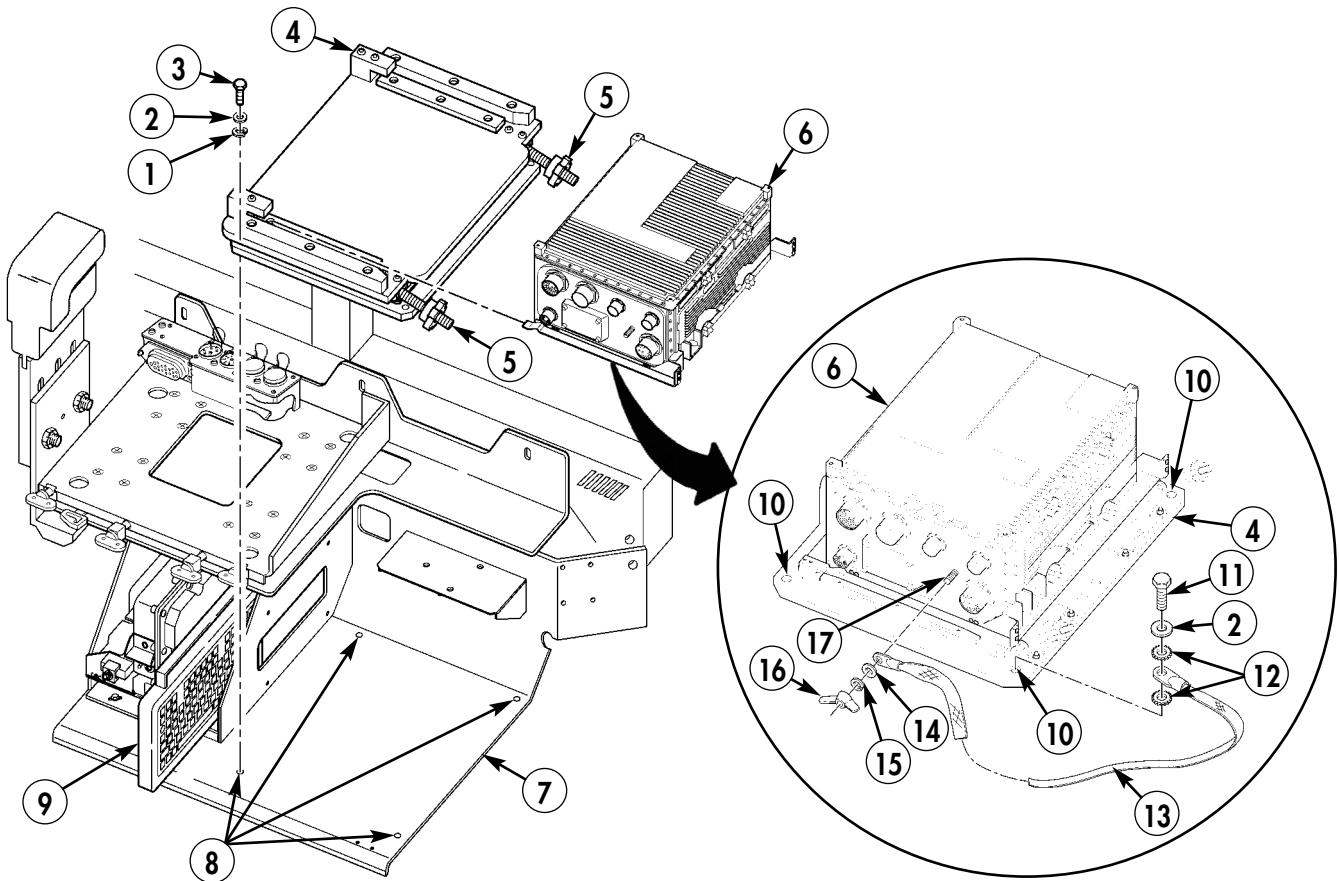

1. LOCKWASHER – MS35338-44 – QTY. 3
2. WASHER – 2436161 – QTY. 4
3. CAPSCREW – B1821BH025C100N – QTY. 3
4. CPU ISOLATION KIT – 872826-2 – QTY. 1
6. CPU – 881292-1 – QTY. 1
11. CAPSCREW – B1821BH025C125N – QTY. 1
12. LOCKWASHER – MS45904-68 – QTY. 2
13. CPU GROUND STRAP
 - BRAIDED WIRE – AA59569F30T0375 – QTY. A/R
 - TERMINAL LUG – MS20659-141 – QTY. 2

Figure 5-17.

- 6-8. Install ramball mount (26) on integrated rack (7) with two screws (25), screw (3), lockwasher (1), lanyard (18), washer (29), three lockwashers (1), and nuts (28).
- 6-9. Install display isolation kit (22) on display lock assembly (21) with four bolts (30), spacers (19), lanyard (18), and four wingnuts (20).
- 6-10. Install display unit (24) on display isolation kit (22) with four screws (23).
- 6-11. Install display lock assembly (21) on ramball mount (26).
- 6-12. Fabricate display ground strap (27) from 8-in. length of braided wire and two terminal lugs.

NOTE

Remove paint from vicinity of integrated rack mounting hole before performing step 6-13. Apply anti-seize compound as required. Ground strap will be installed on integrated rack only when integrated rack is fully secured in vehicle.

- 6-13. Install display ground strap (27) on display ground stud (33) with existing lockwasher (32) and wingnut (31).

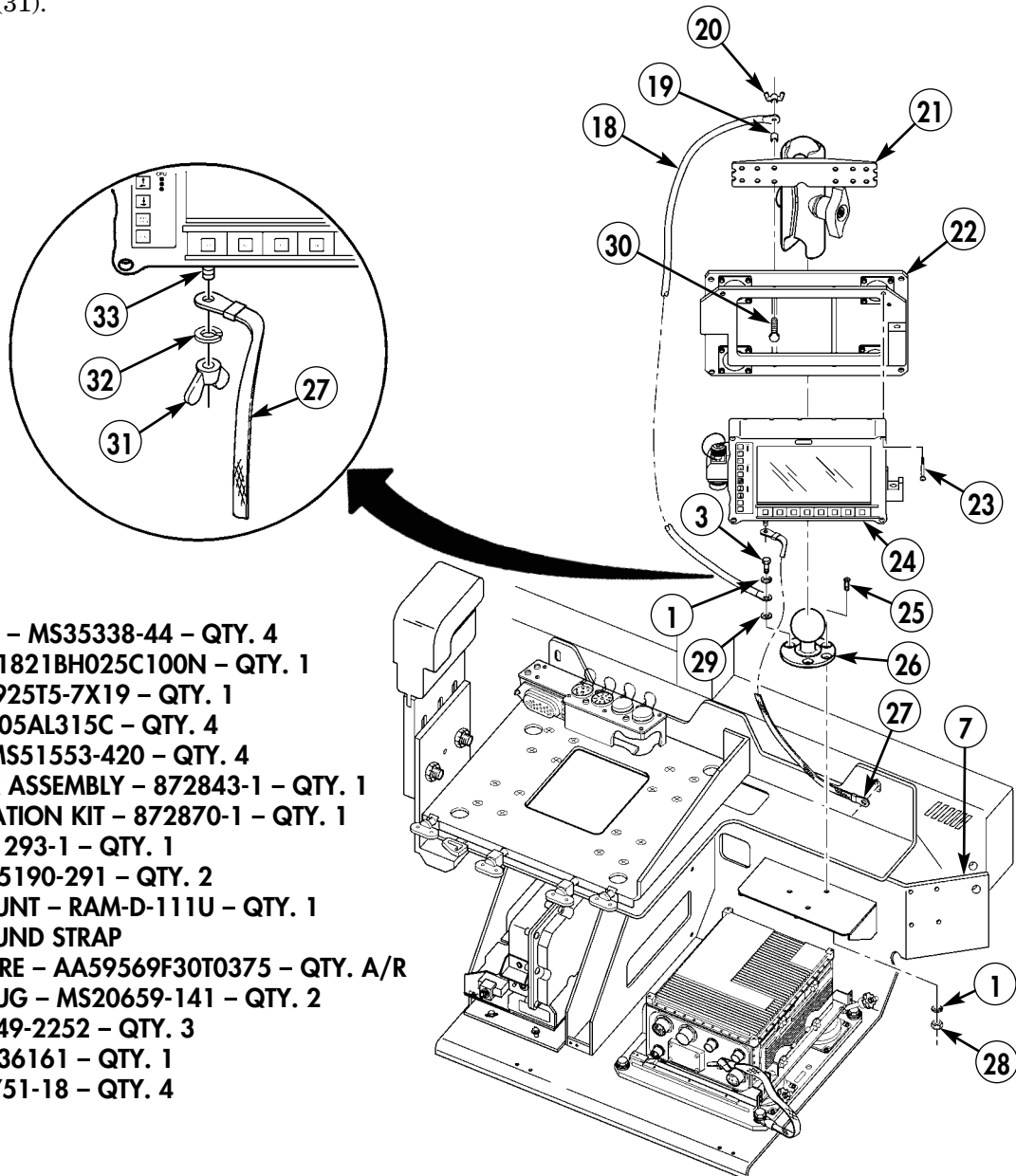

- 1. LOCKWASHER – MS35338-44 – QTY. 4
- 3. CAPSCREW B1821BH025C100N – QTY. 1
- 18. LANYARD – 8925T5-7X19 – QTY. 1
- 19. SPACER – 10705AL315C – QTY. 4
- 20. WINGNUT – MS51553-420 – QTY. 4
- 21. DISPLAY LOCK ASSEMBLY – 872843-1 – QTY. 1
- 22. DISPLAY ISOLATION KIT – 872870-1 – QTY. 1
- 24. DISPLAY – 881293-1 – QTY. 1
- 25. SCREW – MS35190-291 – QTY. 2
- 26. RAMBALL MOUNT – RAM-D-111U – QTY. 1
- 27. DISPLAY GROUND STRAP
 - BRAIDED WIRE – AA59569F30T0375 – QTY. A/R
 - TERMINAL LUG – MS20659-141 – QTY. 2
- 28. NUT – MS35649-2252 – QTY. 3
- 29. WASHER – 2436161 – QTY. 1
- 30. BOLT – MS35751-18 – QTY. 4

Figure 5-18.

Section VI.A. SERIAL INTERFACE ADAPTER DEVICE (SIAD) CABLES INSTALLATION

- 6.A-1. Install W3 cable (4) to SIAD (1).
- 6.A-2. Install W3N cable (2) to SIAD (1).
- 6.A-3. Install W3P cable (3) to SIAD (1).

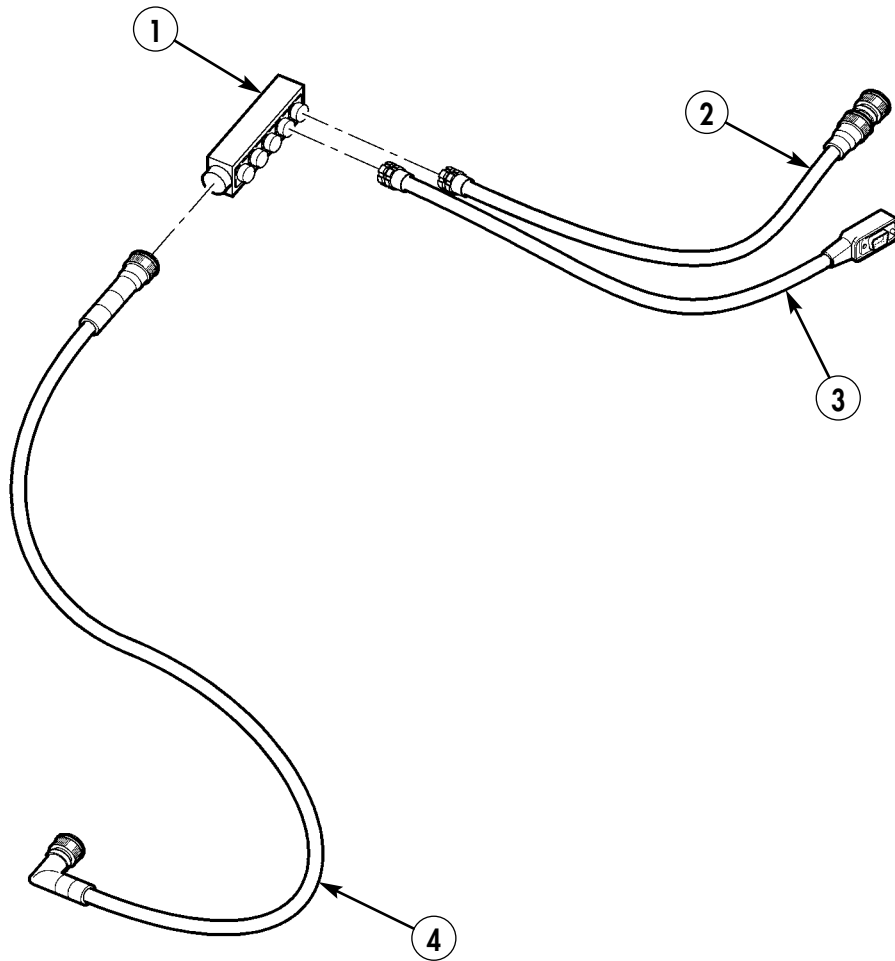

- 1. SERIAL INTERFACE ADAPTER DEVICE – 881331-1 – QTY. 1
- 2. W3N CABLE – 881336-1 – QTY. 1
- 3. W3P CABLE – 881335-1 – QTY. 1
- 4. W3 CABLE – P/O 881331-1 – QTY. 1

Figure 5-18.1.

Section VI.B. SERIAL INTERFACE ADAPTER DEVICE (SIAD) INSTALLATION

Position SIAD (1) securely between FBCB2 (2) and keyboard tray (3) on integrated rack (4).

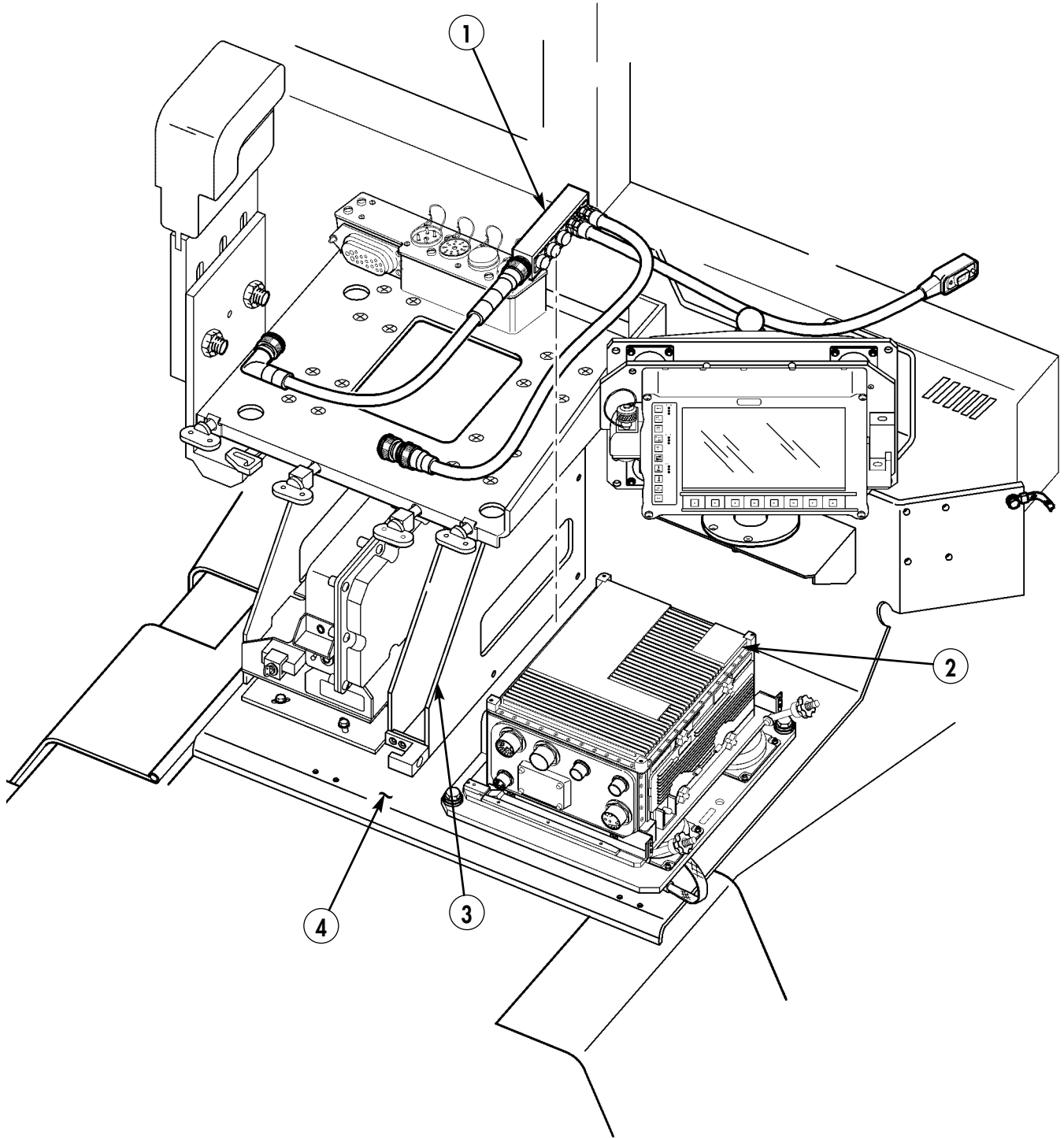
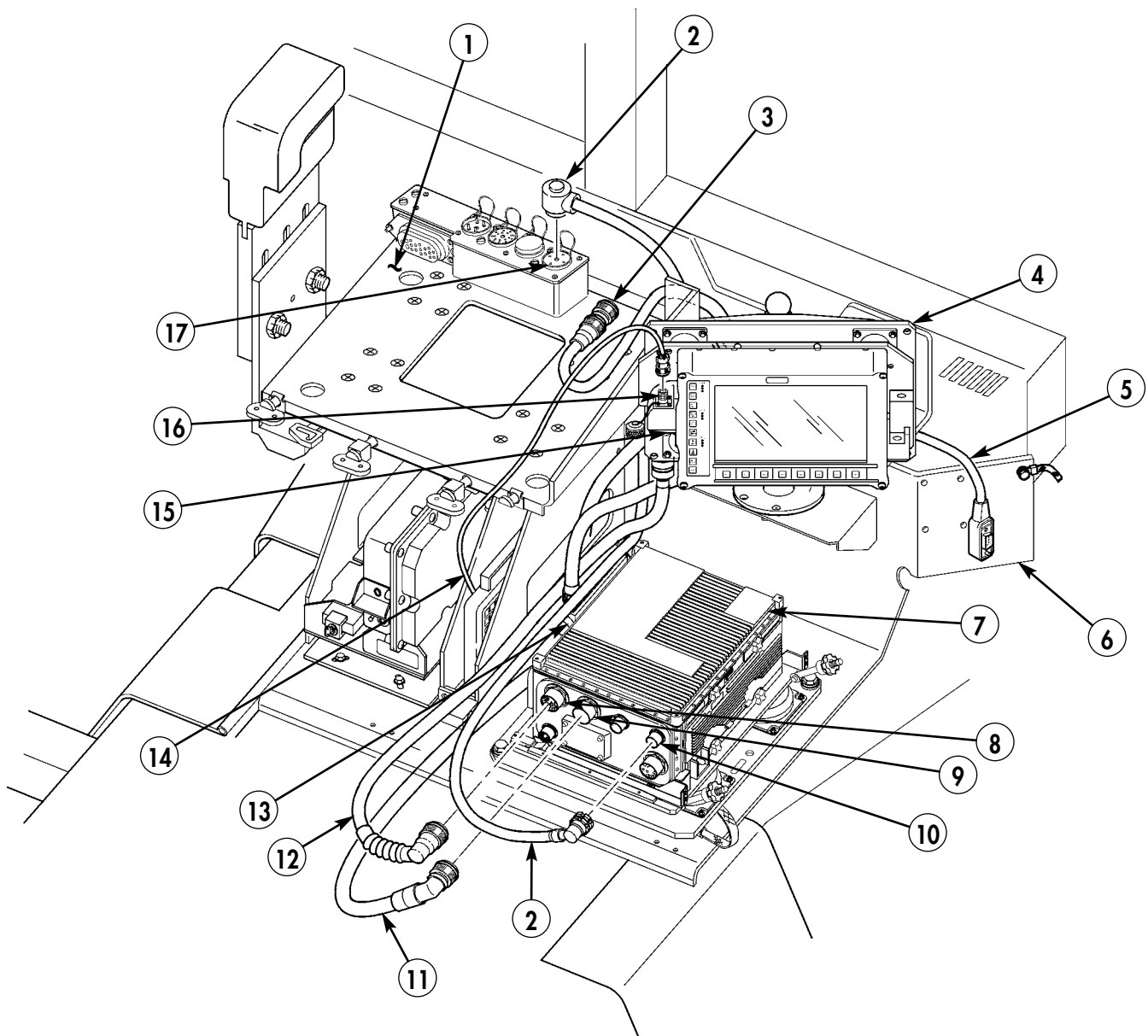

Figure 5-18.2.

Section VI.C. FBCB2 CABLES INSTALLATION

- 6.C-1. Connect W3 cable (11) from SIAD (13) to J3 connector (9) on FBCB2 processor (7).
- 6.C-2. Route W3P cable (5) from SIAD (13) to DAGR mount (6).
- 6.C-3. Connect W2 cable (12) to J4 connector (8) on FBCB2 processor (7) and J1 connector (15) on FBCB2 display unit (4).
- 6.C-4. Connect W1 cable (2) to J1 connector (10) on FBCB2 processor (7). Route W1 cable (2) to A4J2 connector (17).
- 6.C-5. Connect keyboard cable (14) to J2 connector (16) on FBCB2 display unit (4).
- 6.C-6. Route W1J1 cable (3) to SINCGARS mount (1).



- 2. W1 CABLE - 866003-3 - QTY. 1
- 12. W2 CABLE - 881327-1 - QTY. 1

Figure 5-18.3.

6.C-7. Install Vehicular Amplifier Adapter (VAA) (18) into SINCGARS mount (1).

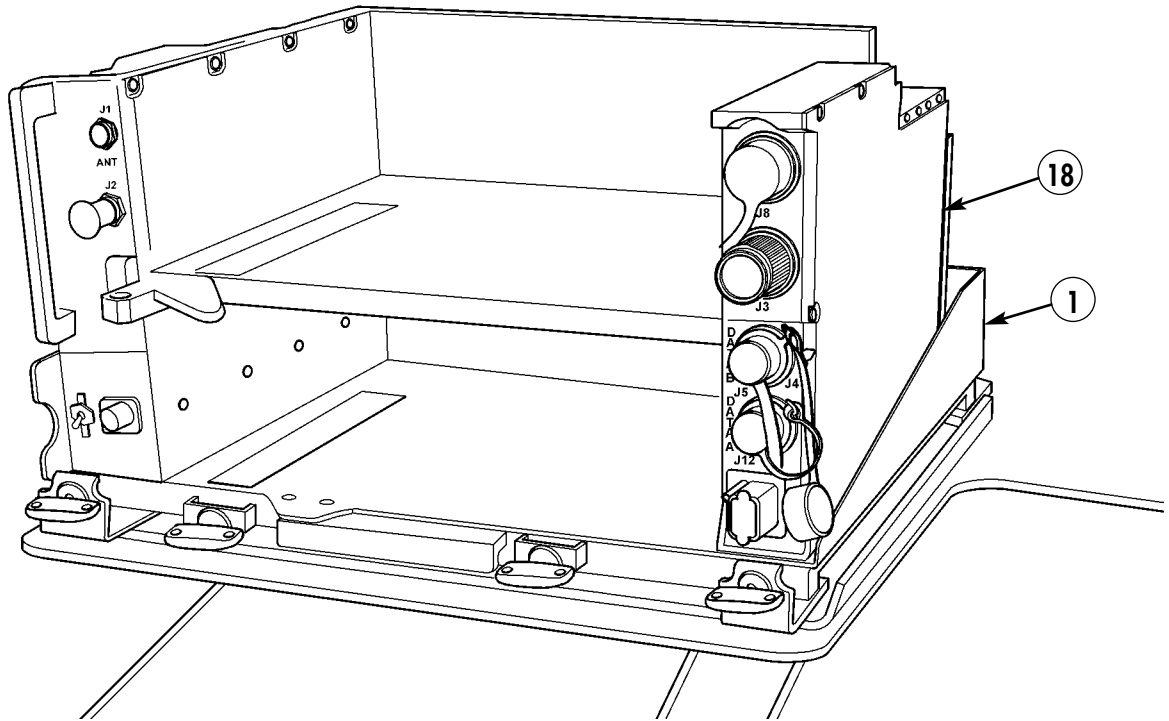

Figure 5-18.4.

6.C-8. Connect W3N cable (19) to J3 (20) connector on VAA (18).

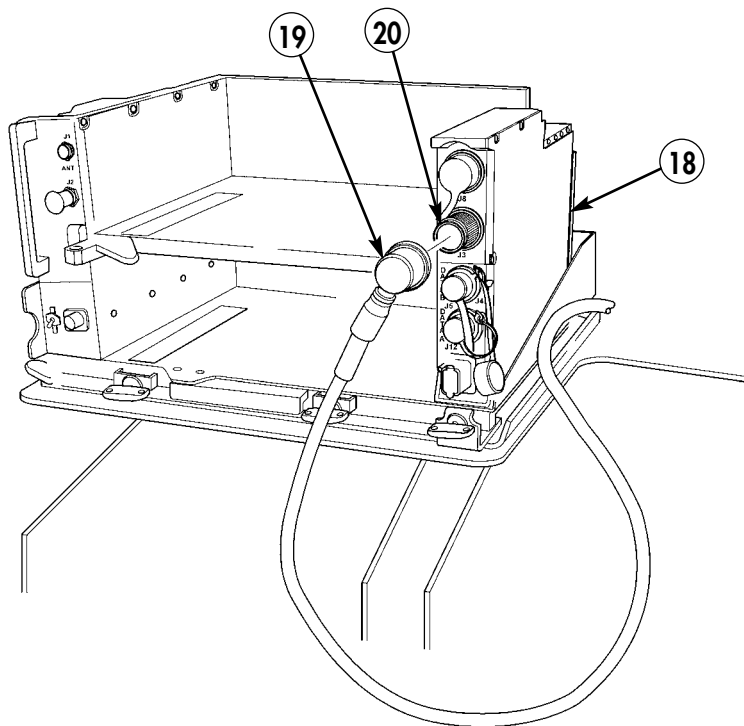
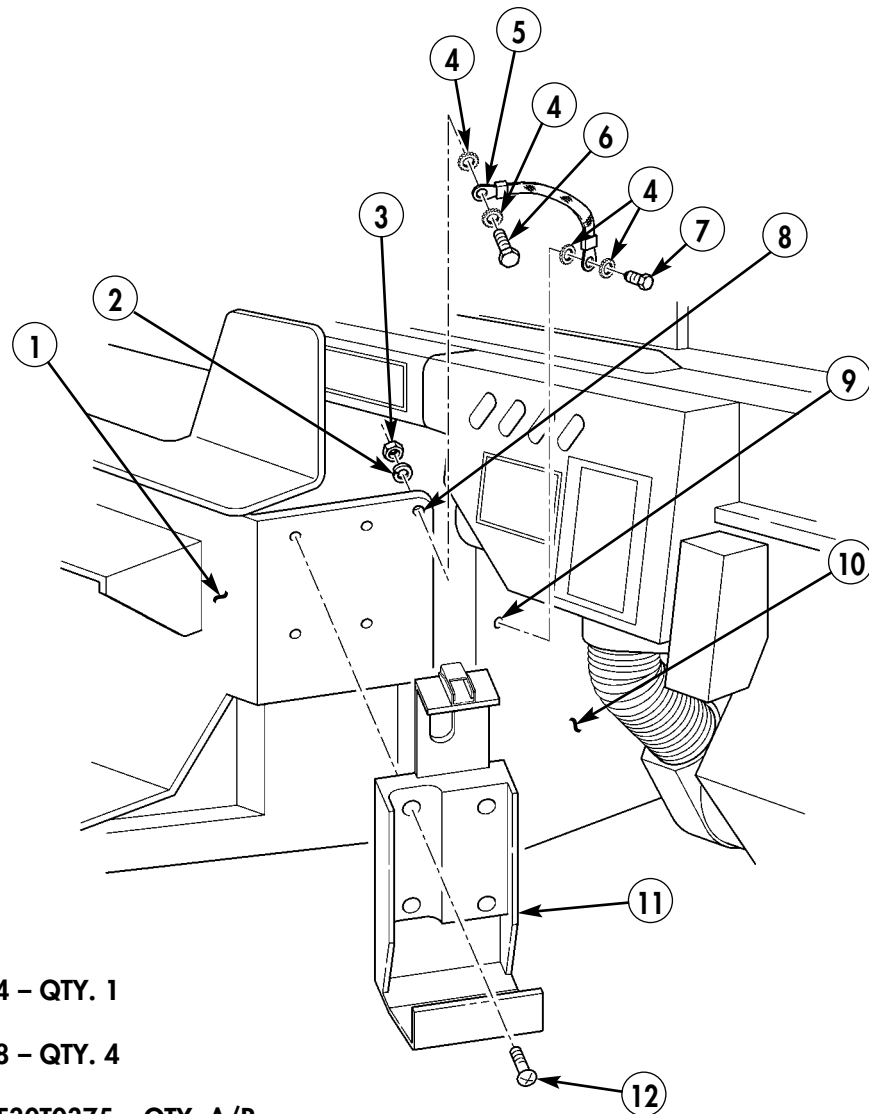

Figure 5-18.5.

Section VII. PLGR BRACKET INSTALLATION

- 7-1. Install PLGR bracket (11) on integrated rack (1) with four screws (12).
- 7-2. Locate, mark, and drill one 0.201-in. diameter hole (9) in right-side engine tunnel (10).
- 7-3. Remove paint from vicinity of hole (8) on integrated rack (1) and hole (9) on right-side engine tunnel (10). Apply anti-seize compound as required.
- 7-4. Fabricate ground strap (5) from 8.00-in. length of braided wire and two terminal lugs.
- 7-5. Install ground strap (5) on integrated rack (1) with capscrew (6), two lockwashers (4), lockwasher (2), and nut (3).
- 7-6. Install ground strap (5) on right-side engine tunnel (10) with self-tapping screw (7) and two lockwashers (4).



2. LOCKWASHER – MS35338-44 – QTY. 1
3. NUT – 9419143 – QTY. 1
4. LOCKWASHER – MS45904-68 – QTY. 4
5. GROUND STRAP
 - BRAIDED WIRE – AA59569F30T0375 – QTY. A/R
 - TERMINAL LUG – MS20659-129 – QTY. 2
6. CAPSCREW – B1821BH025C100N – QTY. 1
7. SELF-TAPPING SCREW – 9426241 – QTY. 1
11. PLGR BRACKET – 986-0645-001 – QTY. 1
12. SCREW – MS35206-263 – QTY. 4

Figure 5-19.

Section VIII. PLGR ANTENNA AND CABLE INSTALLATION (WITHOUT BOLT-ON ARMOR)

- 8-1. Remove plug (6) from existing hole in outside windshield frame (4). Refer to figure 5-21.
- 8-2. Enlarge existing hole (1) in bottom of inside windshield frame (4) to 0.375-in. diameter. Deburr hole (1).
- 8-3. Locate, mark, and drill five 0.156-in. diameter holes (3) in windshield frame (4)
- 8-4. Route PLGR cable (2) through hole (1) in bottom of windshield frame (4), out through existing hole (6) of outside windshield frame (4).

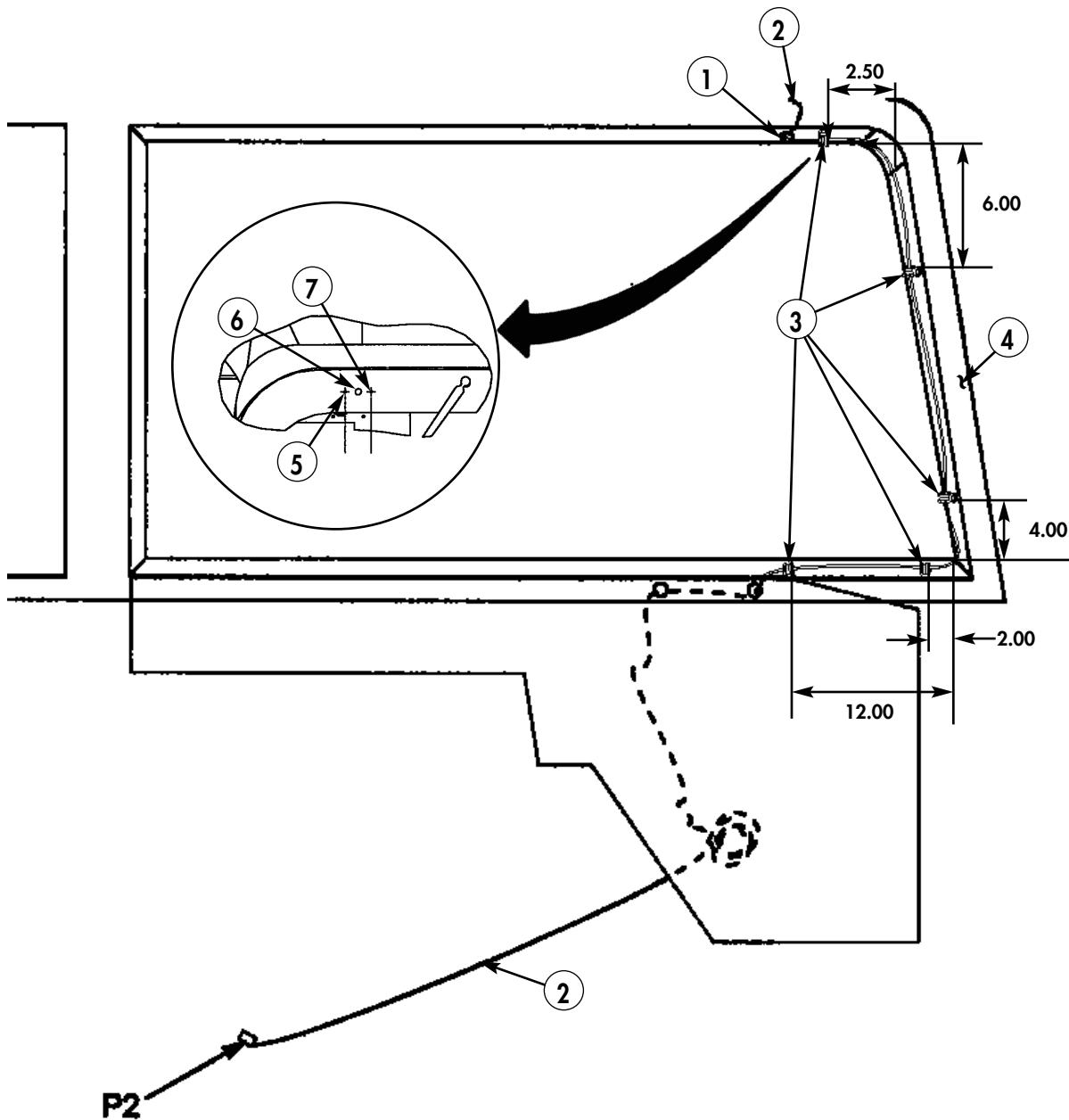

2. PLGR ANTENNA CABLE – 426-0141-050 – QTY. 1

Figure 5-20.

- 8-5. Locate, mark, and drill one 0.173-in. diameter hole (5) in windshield frame (4) using existing hole (7) as starting point.
- 8-6. Secure PLGR antenna (8) to PLGR antenna bracket (9) using screw (12), and lockwasher (11).
- 8-7. Route PLGR cable (2) through PLGR antenna bracket (9) and connect to PLGR antenna (8).
- 8-8. Secure PLGR antenna bracket (9) to windshield frame (4) using two screws (10) and two spacers (13).
- 8-9. Secure PLGR cable (2) to inside windshield frame (4) using five clamps (15) and five screws (14).
- 8-10. Route PLGR cable (2) to vicinity of PLGR bracket.

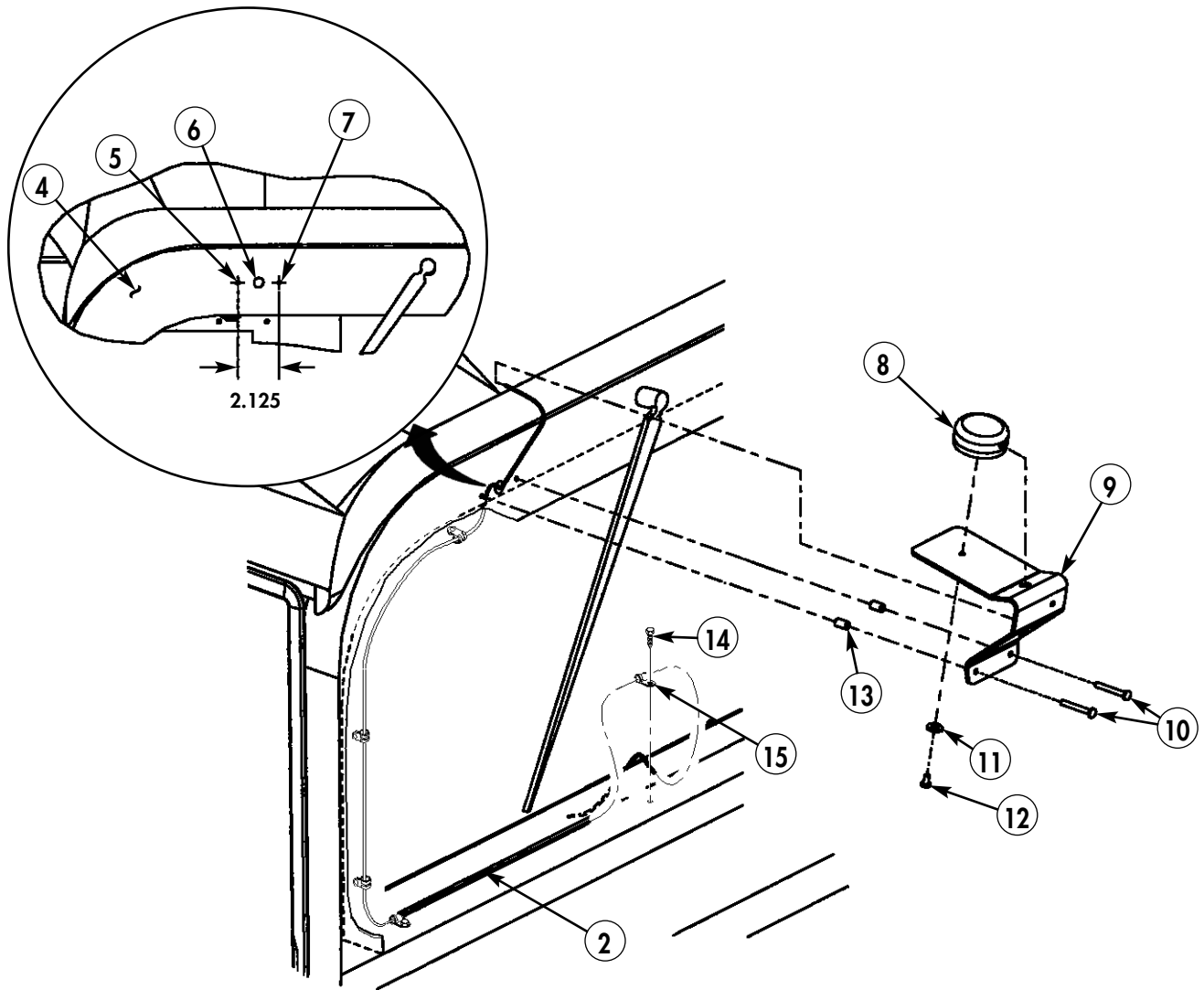

- 8. PLGR ANTENNA - AT575-030 - QTY. 1
- 9. PLGR ANTENNA BRACKET - A3210768 - QTY. 1
- 10. SCREW - 90087A836 - QTY. 2
- 11. LOCKWASHER - MS45904-60 - QTY. 1
- 12. SCREW - MS35207-261 - QTY. 1
- 13. SPACER - 92510A318 - QTY. 2
- 14. SELF-TAPPING SCREW - 9421073 - QTY. 5
- 15. LOOP CLAMP - MS21333-65 - QTY. 5

Figure 5-21.

Section IX. LOUDSPEAKER INSTALLATION

NOTE

Locate two inches from the B-Pillar centerline.

- 9-1. Using speaker mounting plate (4) as template, locate, mark, and drill eight 0.390-in. diameter holes (6) in B-pillar (7).
- 9-2. Locate, mark, and drill two 0.156-in. diameter holes (8) in B-pillar (7).
- 9-3. Install eight inserts (5) in holes (6).
- 9-4. Install two speaker mounting plates (4) on B-pillar (7) using eight capscrews (1), washers (3), and lockwashers (2).
- 9-5. Install loudspeakers (9) on speaker mounting plates (4) using four screws (12).
- 9-6. Install handset (11) on speaker connector (10).

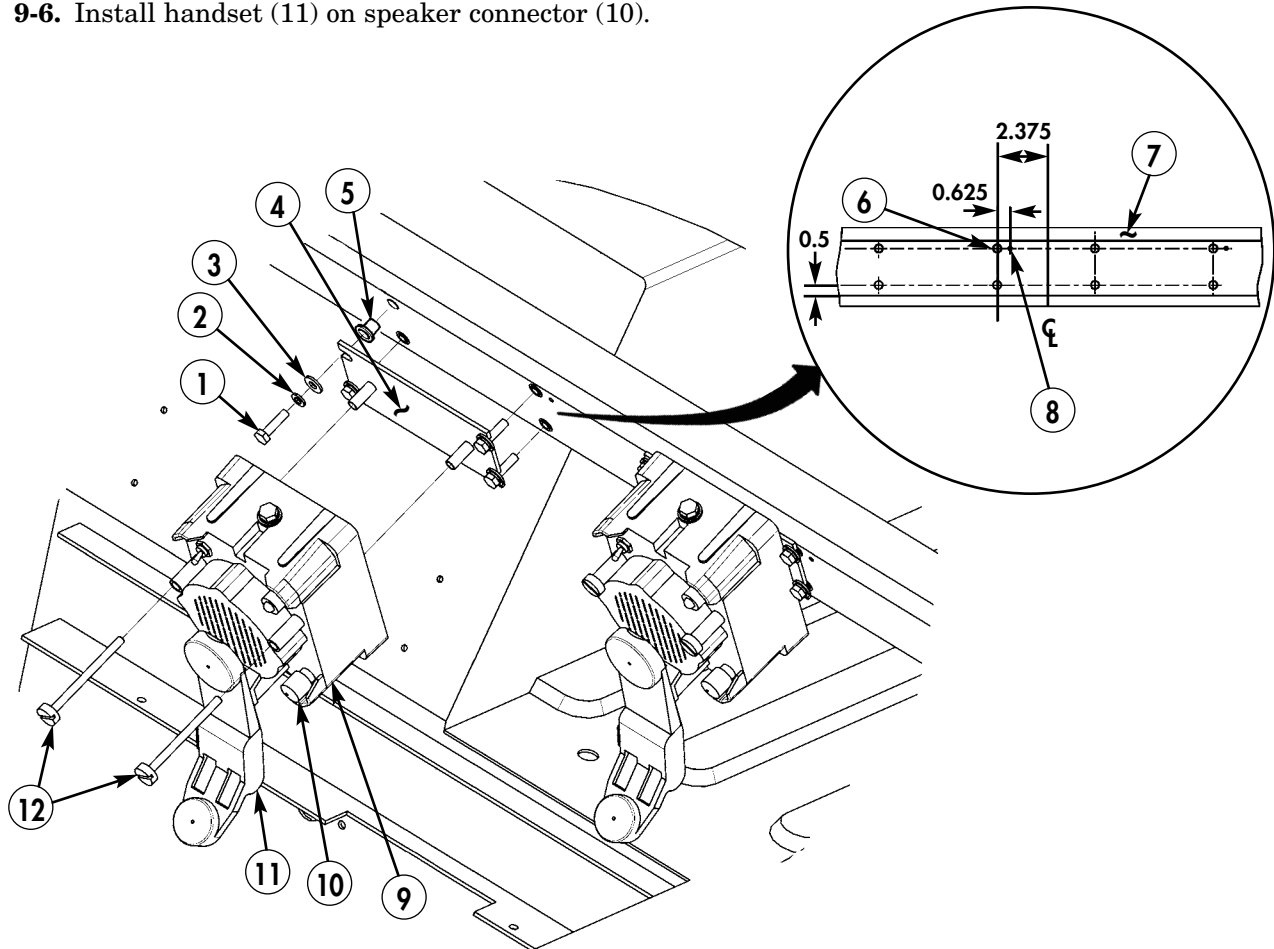

1. SCREW – MS90725-8 – QTY. 8
2. LOCKWASHER – MS35338-43 – QTY. 8
3. WASHER – MS27183-10 – QTY. 8
4. MOUNTING PLATE– A3014550-1 – QTY. 2
5. INSERT – ALS4-420-165 – QTY. 8
9. LOUDSPEAKER – A3014065-1 – QTY. 2
11. HANDSET – H-250/U – QTY. 2
12. SCREW – P/O A3014065-1 – QTY. 4

Figure 5-22.

Section X. LOUDSPEAKER CABLE INSTALLATION

- 10-1. Connect right speaker cable (3) to loudspeaker port (1).
- 10-2. Connect left speaker cable (5) to loudspeaker port (1).
- 10-3. Secure speaker cables (3) and (5) to B-pillar in previously drilled holes with two cable clamps (4) and screws (2).

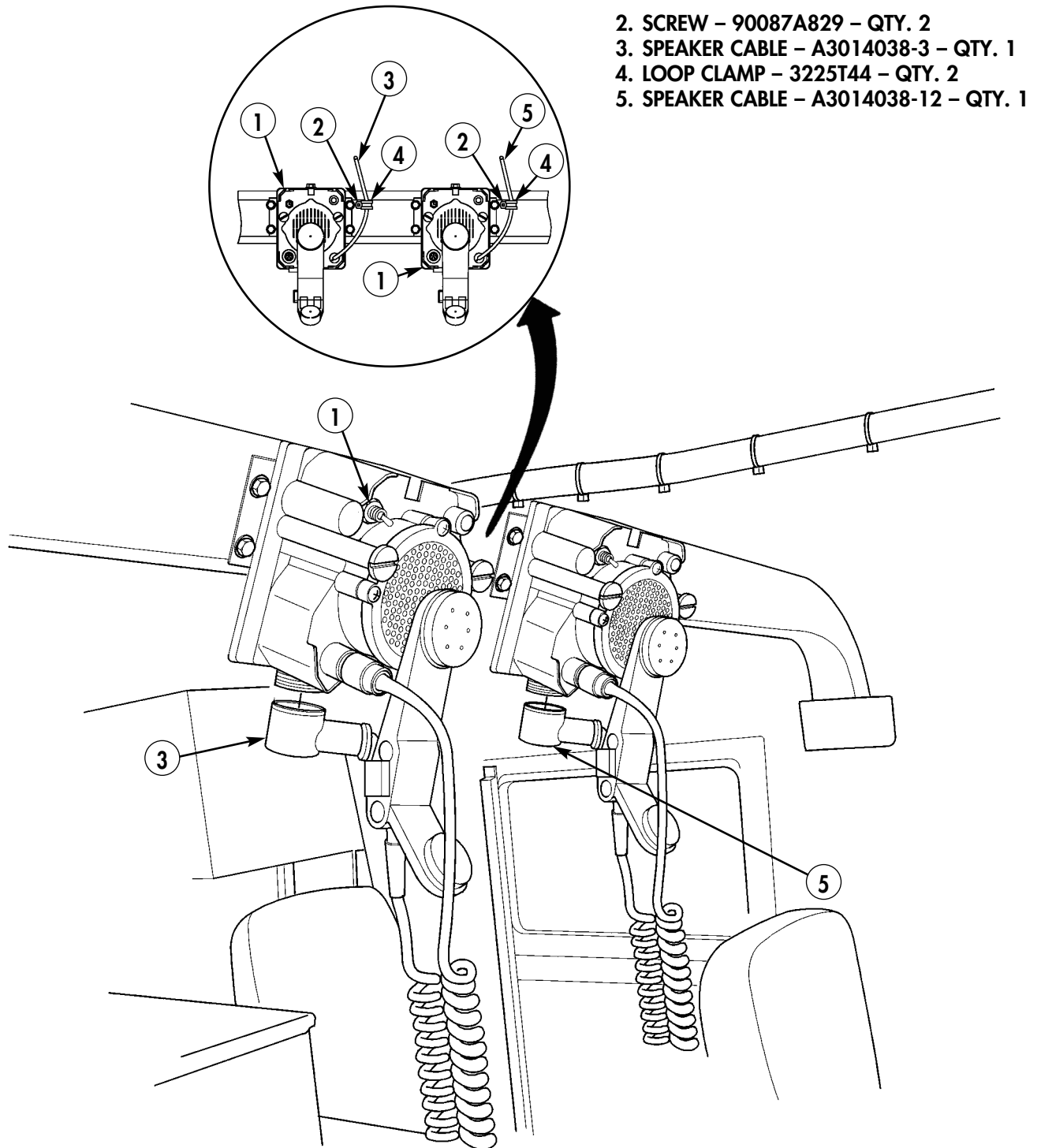

Figure 5-23.

- 10-4. Locate, mark, and drill two 0.156-in. diameter holes (9) in windshield center post (12).
- 10-5. Secure speaker cables (3) and (5) to windshield center post (12) with upper right bolt (6) from wiper motor and clamp (7).

NOTE

Before tightening three cable clamps pull excess cable below bottom cable clamp on windshield center post.

- 10-6. Install two cable clamps (10) on windshield center post (12) with two self-tapping screws (11).
- 10-7. Install twelve tie straps (8), evenly spaced along speaker cables, between loudspeakers and top cable clamp on windshield center post.
- 10-8. Install three cable straps (8) to speaker cables (3) and (5) along windshield center post (12).
- 10-9. Connect speaker cables (3) and (5) to mounting base (13).

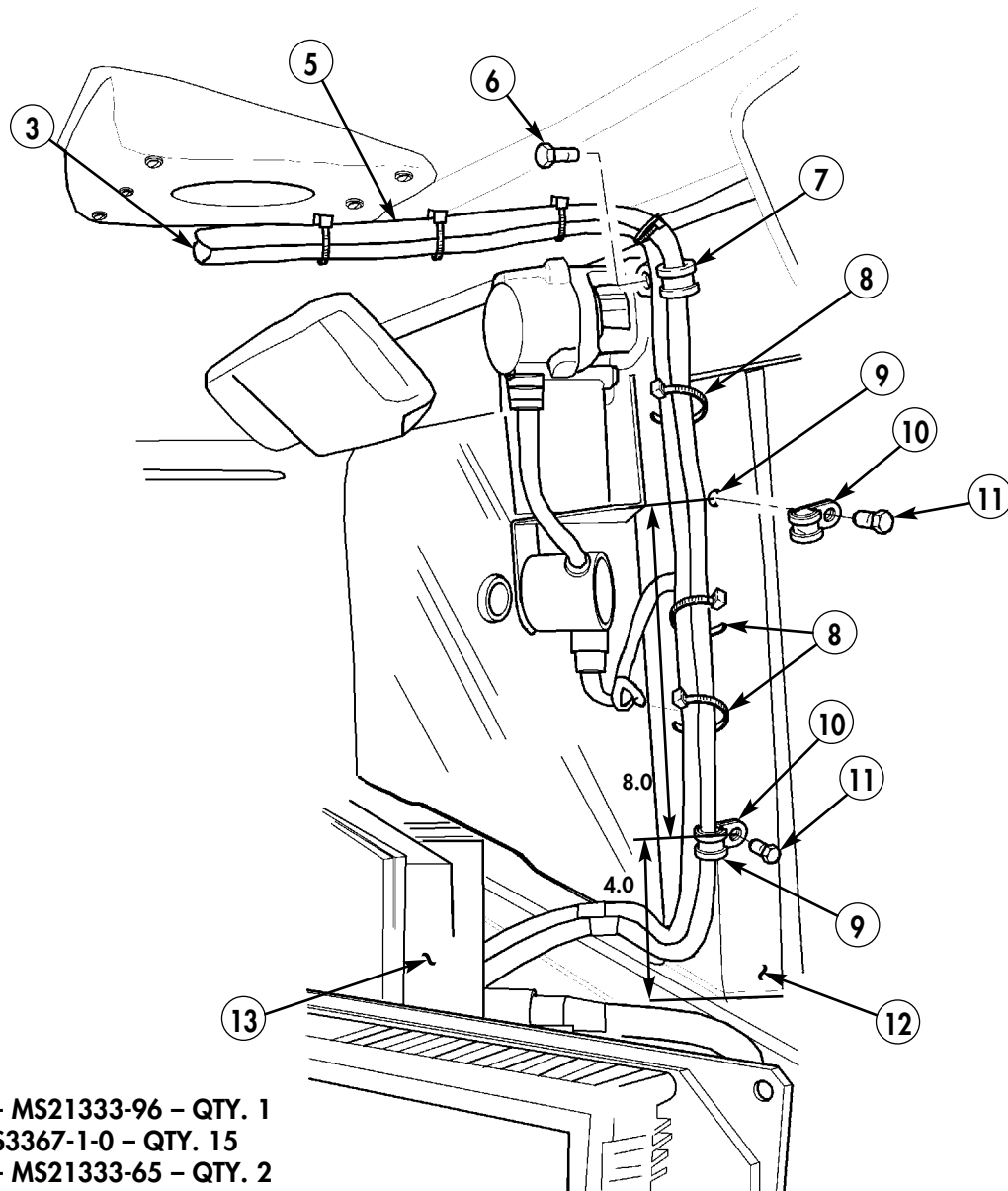

- 7. LOOP CLAMP – MS21333-96 – QTY. 1
- 8. TIE STRAP – MS3367-1-0 – QTY. 15
- 10. LOOP CLAMP – MS21333-65 – QTY. 2
- 11. SELF-TAPPING SCREW – 9421073 – QTY. 2

Figure 5-24.

Section XI. COMPUTER STAND ASSEMBLY INSTALLATION

11-1. Locate, mark, and drill six .380-in. diameter holes (1).

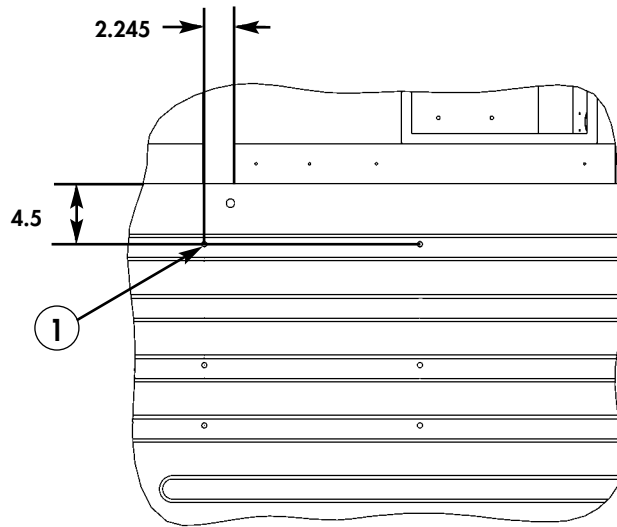
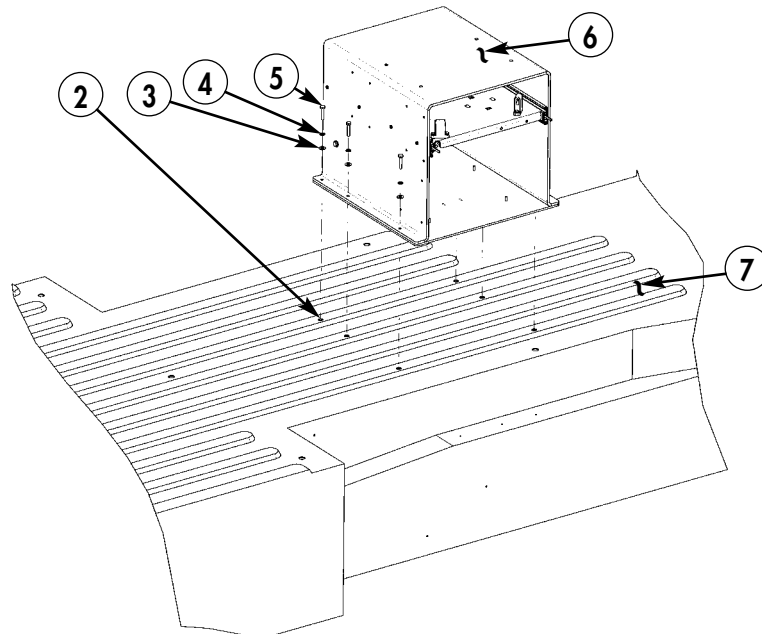

Figure 5-25.

11-2. Install inserts (2) in holes (1).

11-3. Position laptop housing assembly (6) over inserts (2) in cargo floor (7).

11-4. Install laptop housing assembly (6) in cargo floor (7) with six screws (5), lockwashers (4), and washers (3).



- 2. INSERT - ALS4-420-165 - QTY. 6
- 3. WASHER - MS27183-10 - QTY. 6
- 4. LOCKWASHER - MS35338-44 - QTY. 6
- 5. CAPSCREW - MS90725-10 - QTY. 6
- 6. COMPUTER STAND ASSEMBLY - A3265632 - QTY. 1

Figure 5-26.

Section XII. URO BRACKET INSTALLATION

12-1. Locate predrilled holes (7) in rear wall of computer stand (3).

12-2. Secure URO brackets (2) to computer stand (3) with eight screws (9), sixteen washers (6), eight spacers (8), lockwashers (5), and nuts (4).

12-3. Secure URO cables (10) to URO brackets (2) with eight bolts (1) and nuts (11).

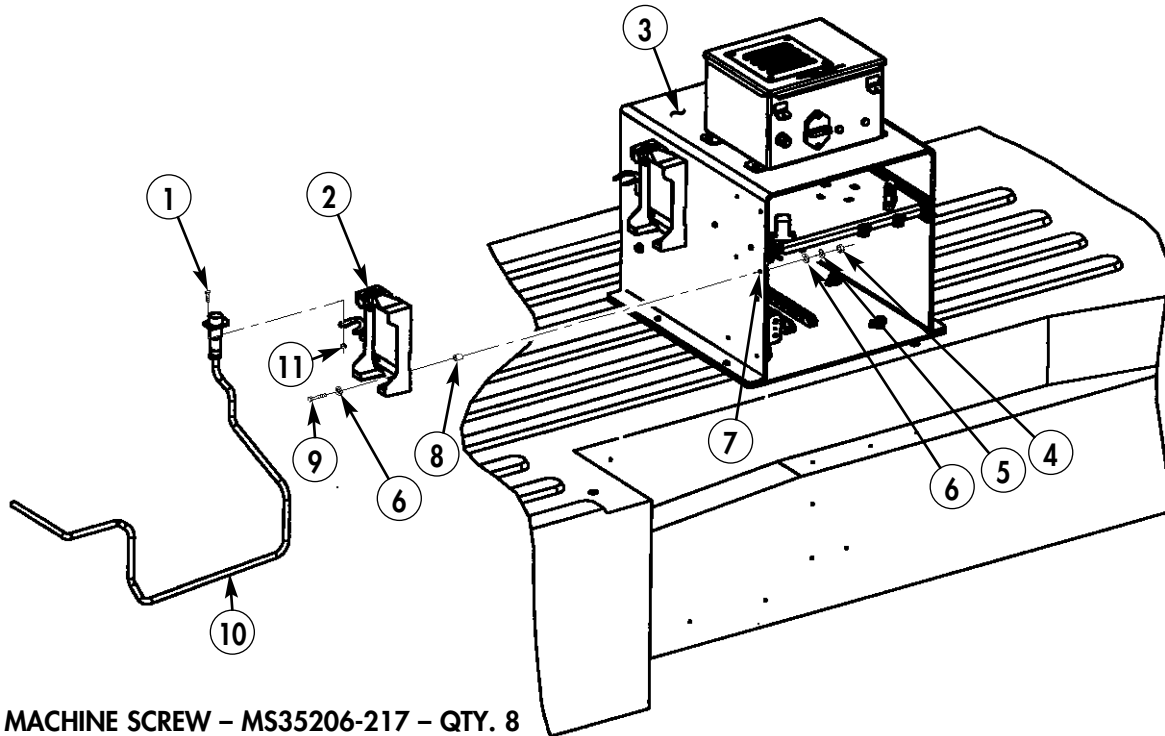

- 1. MACHINE SCREW - MS35206-217 - QTY. 8
- 2. URO BRACKET - A3006206-2 - QTY. 2
- 4. NUT - MS35650-302 - QTY. 8
- 5. LOCKWASHER - MS35338-43 - QTY. 8
- 6. WASHER - MS27183-8 - QTY. 16
- 8. SPACER - 92510A318 - QTY. 8
- 9. SCREW - MS35207-268 - QTY. 8
- 10. URO CABLE - A3005328 - QTY. 2
- 11. NUT - 90675A005 - QTY. 8

Figure 5-27.

Section XIII. MASTER KILL SWITCH BOX INSTALLATION

13-1. Locate four predrilled 0.266-in. diameter holes (5) in top of computer stand (1).

13-2. Secure master kill switch box (2) to computer stand (1) using four bolts (3) and lockwashers (4).

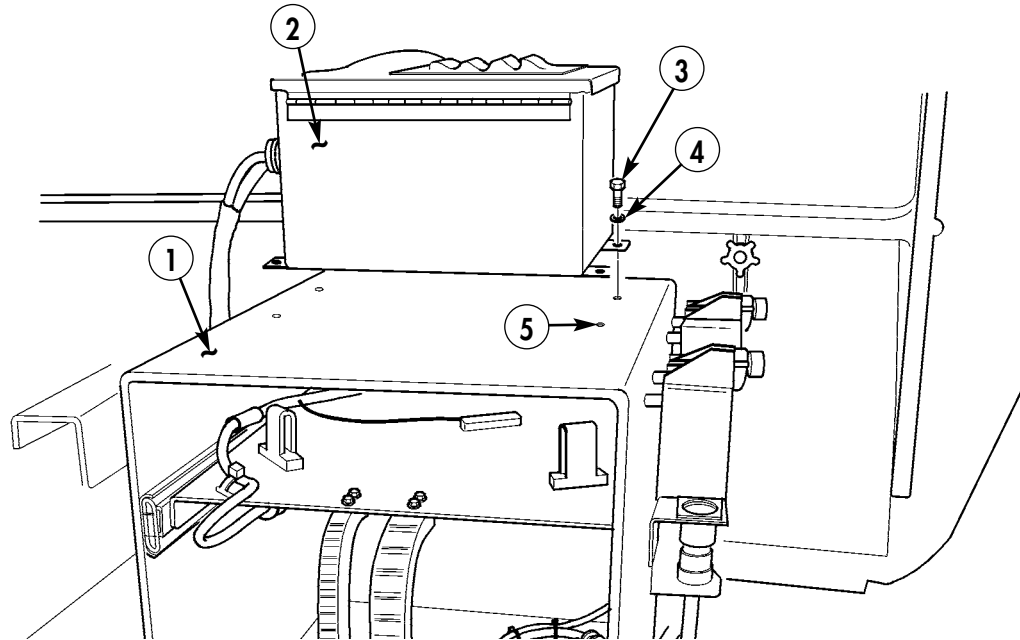

2. MASTER KILL SWITCH BOX - A3265670 - QTY. 1

3. SCREW - MS90725-6 - QTY. 4

4. LOCKWASHER - MS45904-68 - QTY. 4

Figure 5-28.

Section XIV. COMPUTER STAND CABLE INSTALLATION

- 14-1. Assemble and install front cable carrier (11) on shelf (1) with two screws (9), nuts (8), and screws (7).
- 14-2. Route Ethernet cable (6) along bottom of shelf (1) to front cable carrier (11).
- 14-3. Assemble and install rear cable carrier (10) on shelf (1) with two screws (9), nuts (8), and screws (7).
- 14-4. Route PCMCIA cable (5) along bottom of shelf (1) to rear cable carrier (10) and secure PCMCIA cable (5) to shelf (1) using screw (3) and clamp (4).
- 14-5. Route DC-DC cable (2) along bottom of shelf (1) to rear cable carrier (10) and secure DC-DC cable (2) to shelf (1) using screw (3) and clamp (4).
- 14-6. Route Parallel cable (13) along bottom of shelf (1) to rear cable carrier (10) and secure Parallel cable (13) to shelf (1) using existing screw (12) and clamp (4).

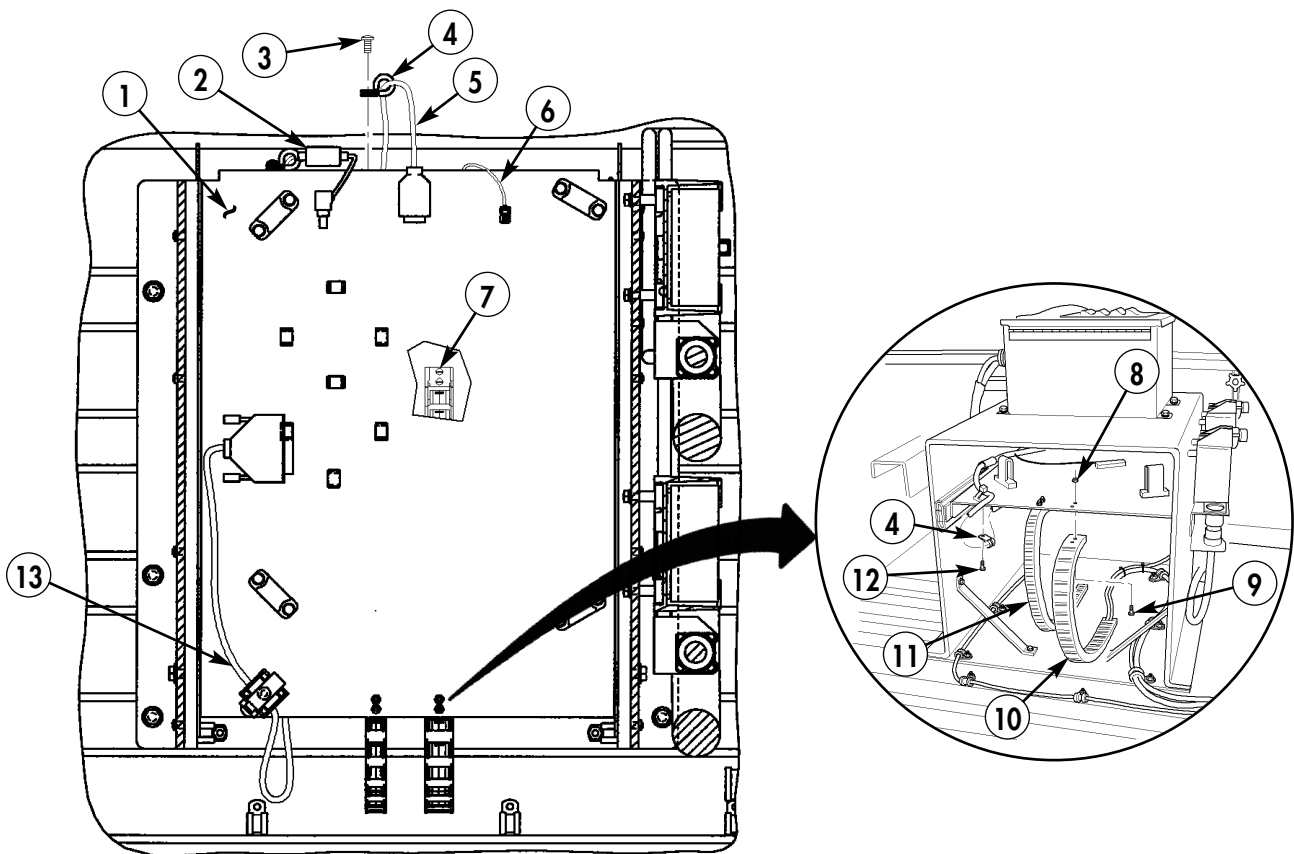

2. DC-DC POWER ADAPTER CABLE
- P/O PA1540-647 - QTY. 1
3. SCREW - MS35207-263 - QTY. 2
4. LOOP CLAMP - 3225T43 - QTY. 3
5. PCMCIA CABLE - A3265957 - QTY. 1
6. ETHERNET CABLE - A3265597 - QTY. 1

7. SCREW - 93195A1113 - QTY. 4
8. NUT - 90675A005 - QTY. 4
9. SCREW - MS51959-15 - QTY. 4
10. CABLE CARRIER - 55835K44 - QTY. 1
11. CABLE CARRIER - 55835K42 - QTY. 1
13. PARALLEL CABLE - P/O A3265640 - QTY. 1

Figure 5-29.

14-7. Secure DC-DC adapter (16) to computer stand (17) with two straps (14) and four screws (15).

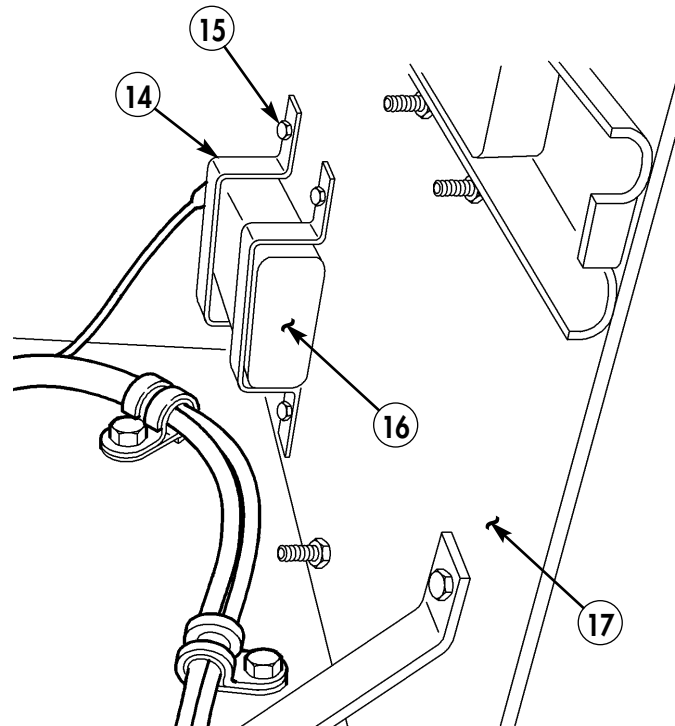

- 14. STRAP – 3051T42 – QTY. 2
- 15. SCREW – MS35207-265 – QTY. 4
- 16. DC-DC ADAPTER – PA1540-647 – QTY. 1

Figure 5-30.

Section XV. MULTI-NET RACK INSTALLATION

15-1. Remove three existing tiedown D-rings (1) from cargo floor (2).

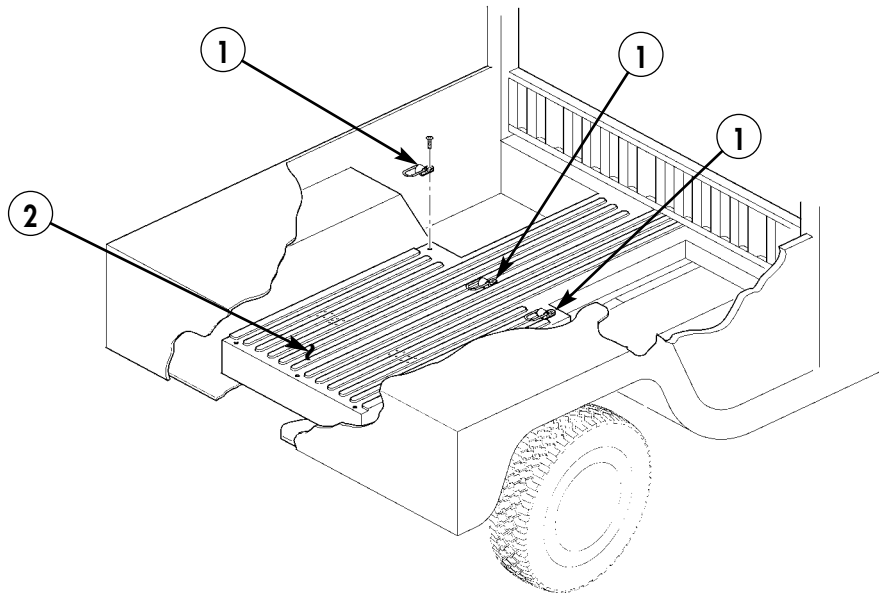
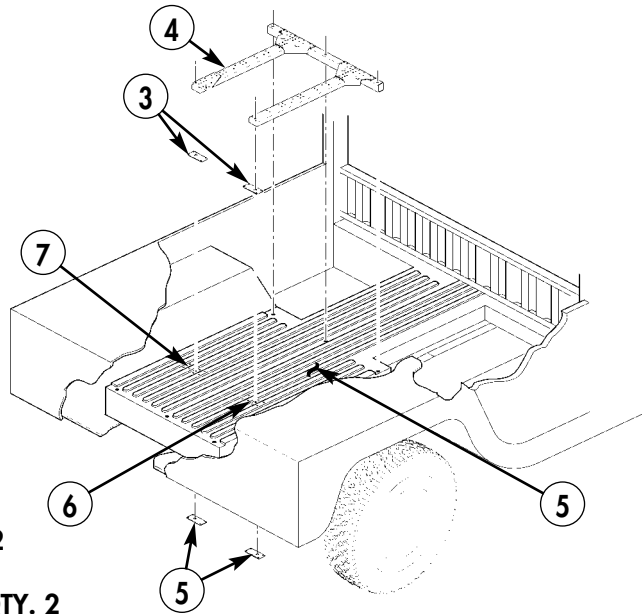

Figure 5-31.

15-2. Using multi-net rack frame (4) as template, locate, mark, and drill two 0.531-in. diameter holes (6) in cargo floor (2).

15-3. Using rivet plates (3) as templates, locate, mark, and drill eight 0.1875-in. diameter holes (7) in cargo floor (2).

15-4. Using underbody support plates (5) as templates, locate, mark, and drill eight 0.1875-in. diameter holes (7) in cargo floor (2).



- 3. SPACER PLATE (TOP) – A3265611 – QTY. 2**
- 4. MOUNTING FRAME – A3265612 – QTY. 1**
- 5. SPACER PLATE (BOTTOM) – A3265609 – QTY. 2**

Figure 5-32.

15-5. Attach two underbody support plates (5) to underside of cargo floor (2) with eight rivets (8).

15-6. Attach two rivet plates (3) to cargo floor (2) with eight rivets (8).

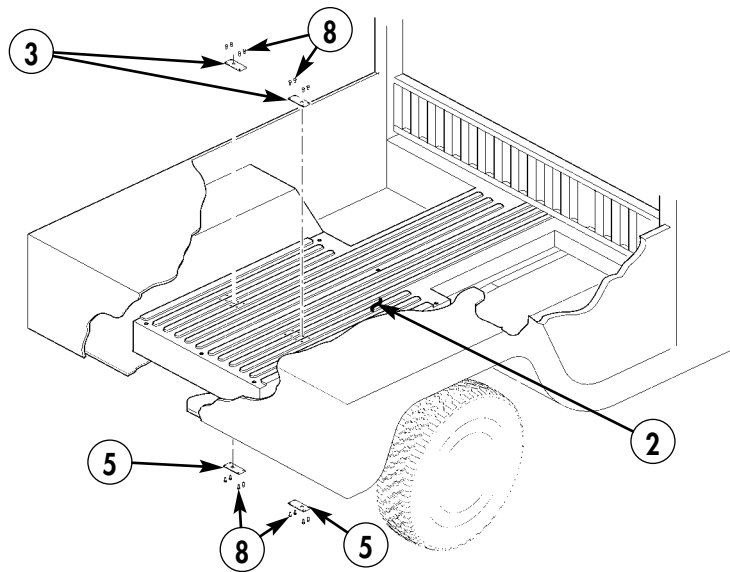
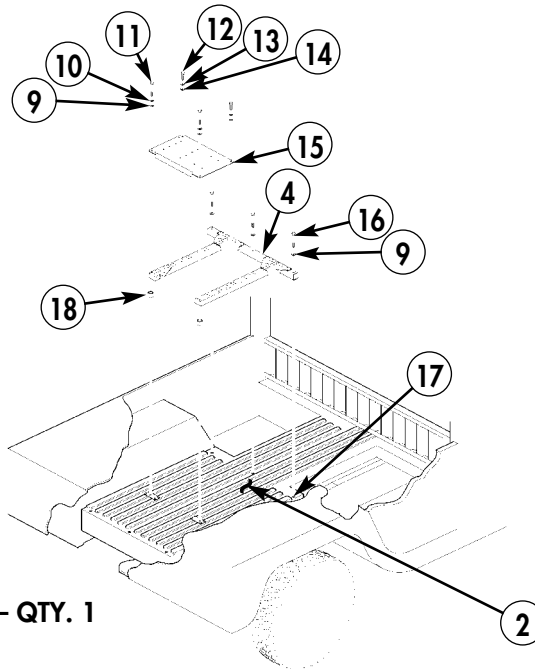

Figure 5-33.

15-7. Attach multi-net rack frame (4) to cargo floor (2) with three screws (16), washers (9), and existing locknuts (17).

15-8. Attach mounting plate (15) to multi-net frame (4) with two screws (11), spacers (18), washers (9), lockwashers (10), bolts (12), lockwashers (13), and washers (14).



- 9. WASHER - MS27183-18 - QTY. 5
- 10. LOCKWASHER - MS35338-48 - QTY. 2
- 11. SCREW - MS90725-123 - QTY. 2
- 12. SCREW - MS90726-62 - QTY. 2
- 13. LOCKWASHER - MS35338-46 - QTY. 2
- 14. WASHER - MS27183-14 - QTY. 2
- 15. FRAME MOUNTING PLATE - A3265610 - QTY. 1
- 16. SCREW - MS90725-125 - QTY. 3
- 18. SPACER - P/O A3265612 - QTY. 2

Figure 5-34.

NOTE

Assemble shelves to supports with holes designated "A" facing in same direction.

- 15-9.** Install two shelves (21) on supports (22) with sixteen screws (20), thirty-two lockwashers (19), and sixteen locknuts (23). Do not tighten locknuts (23) at this time.
- 15-10.** Install two braces (28) on shelves (21) with two screws (20), screws (25), lockwashers (19), washers (26), locknuts (23), and locknuts (24). Do not tighten locknuts at this time.
- 15-11.** Install center support (27) on shelves (21) with four screws (20), lockwashers (19), and locknuts (23). Do not tighten locknuts (23) at this time.

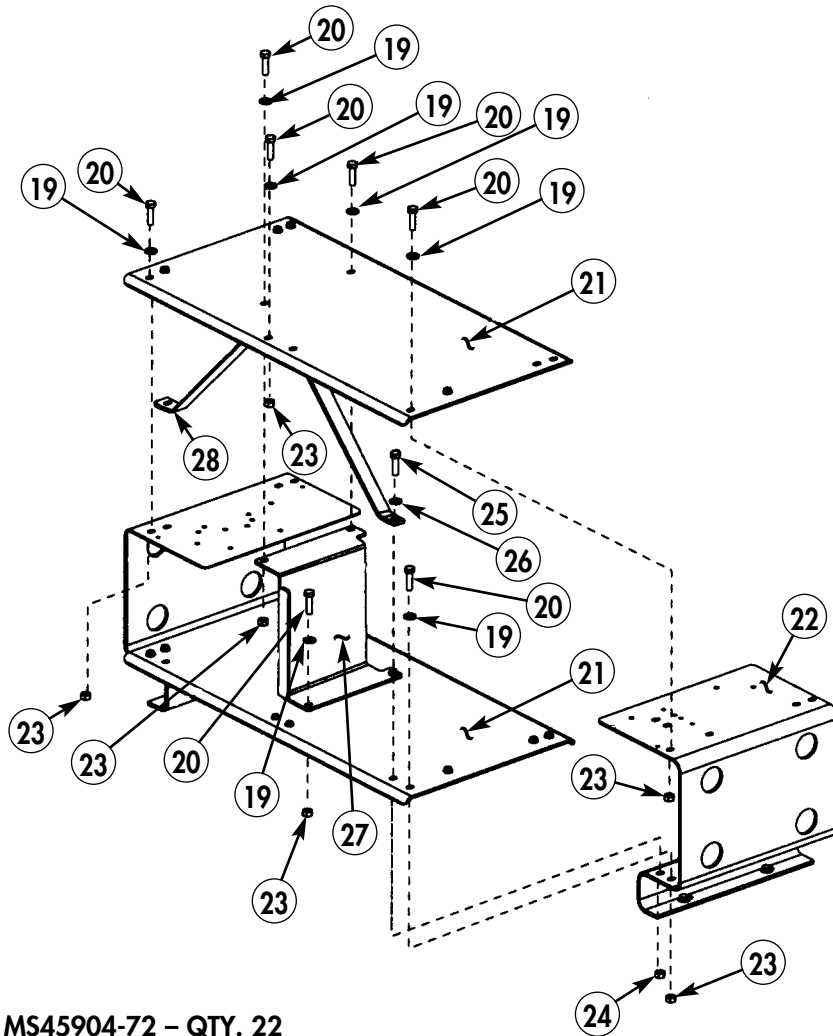

19. LOCKWASHER – MS45904-72 – QTY. 22
 20. SCREW – MS90726-36 – QTY. 22
 21. SHELF, ELECTRICAL – A3046236 – QTY. 2
 22. SUPPORT, RADIO RACK – A3046235 – QTY. 2
 23. NUT – MS51967-5 – QTY. 22
 24. NUT – MS51967-2 – QTY. 2
 25. SCREW – MS90725-8 – QTY. 2
 26. WASHER – 2436161 – QTY. 2
 27. CENTER SUPPORT – A3265621 – QTY. 1
 28. BRACE, ANGLE – A3046237 – QTY. 2

Figure 5-35.

5-12. Locate, mark, and drill five 0.281-in. diameter holes (29) in multi-net rack top shelf (30).

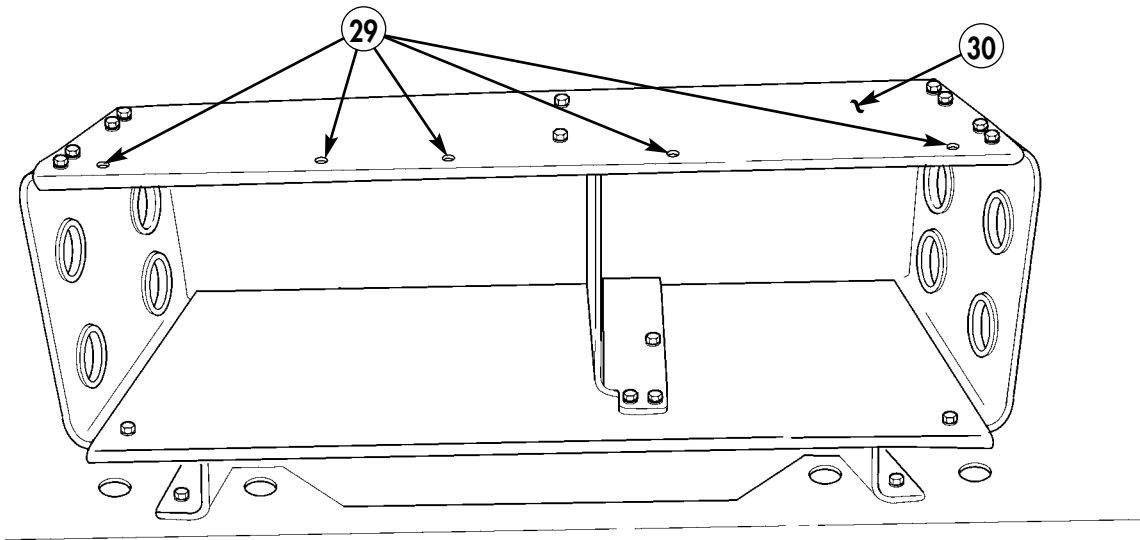

Figure 5-36.

5-13. Secure multi-net rack (31) to multi-net rack frame (4) with four screws (32) and lockwashers (33).

5-14. Locate, mark, and drill one 0.147-in. diameter hole (37) in rear seat support (36).

5-15. Locate, mark, and drill two 0.147-in. diameter holes (34) in multi-net rack frame (4).

5-16. Locate, mark, and drill one 0.147-in. diameter hole (35) in multi-net rack (31).

5-17. Connect rear seat support (36) to multi-net rack frame (4) and multi-net rack (31) with two ground straps (39) and three screws (38).

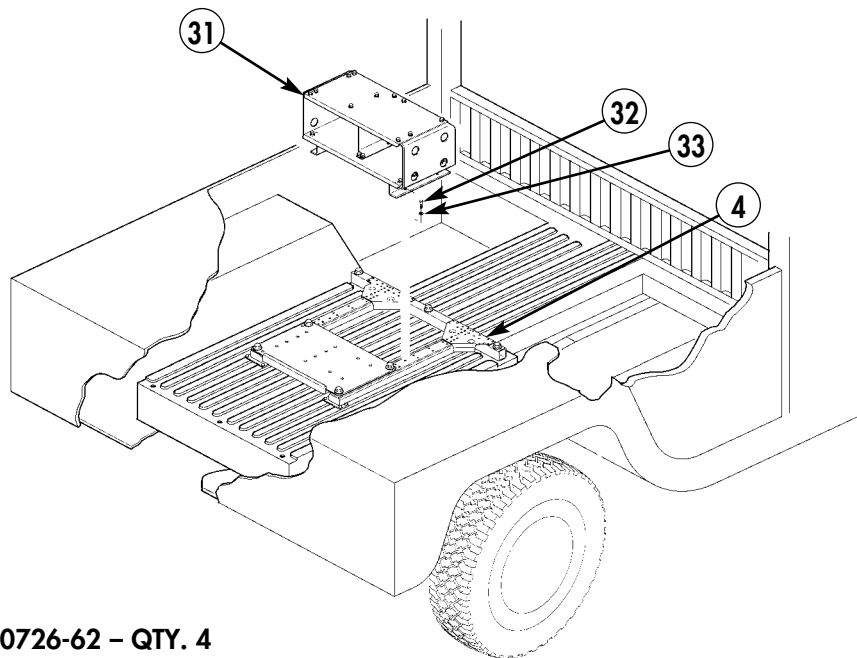

- 32. SCREW – MS90726-62 – QTY. 4
- 33. LOCKWASHER – MS35333-76 – QTY. 4

Figure 5-37.

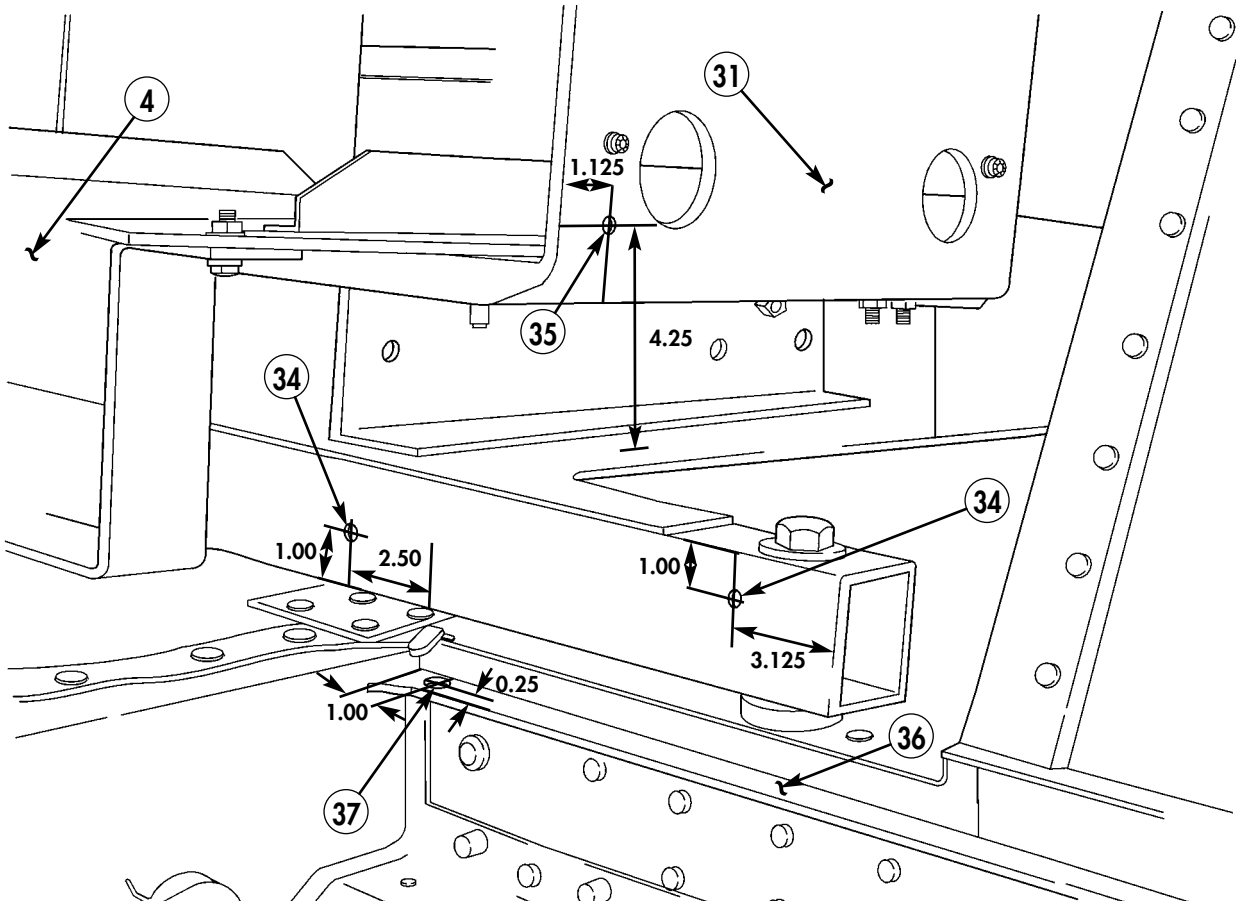
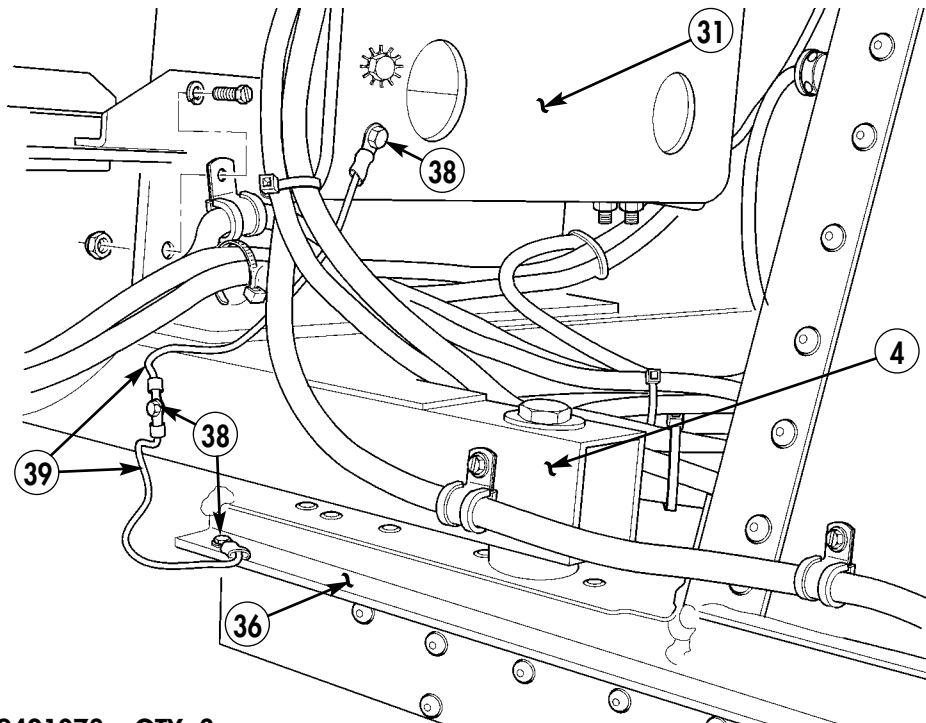

Figure 5-38.



- 38. SCREW - 9421073 - QTY. 3
- 39. GROUND STRAP - 10208-3506-01 - QTY. A/R

Figure 5-39.

Section XVI. EPLRS DUAL MOUNT INSTALLATION

- 16-1. Insert two screws (14) and lockwashers (13) in holes (12).
- 16-2. Using EPLRS rack spacer (9) as template, locate, mark, and drill two 0.3125-in. diameter holes (11) in top shelf of multi-net rack (10).
- 16-3. Enlarge two holes (11) in EPLRS rack spacer (9) to 0.3125-in. diameter.
- 16-4. Using EPLRS rack spacer (9) as template, locate, mark, and drill two 0.3125-in. diameter holes (15) in EPLRS dual mount lower half (8).
- 16-5. Enlarge four holes (3) in EPLRS dual mount upper half (2) to 0.3125-in. diameter.
- 16-6. Attach EPLRS mount (1), rack spacer plate (9), and EPLRS dual mount lower half (8) to multi-net rack (10) with four screws (14), washers (16), lockwashers (13), and nuts (17).
- 16-7. Attach EPLRS dual mount upper half (2) to EPLRS dual mount lower half (8) with six screws (7), six lockwashers (5), twelve washers (4), and six nuts (6).
- 16-8. Attach EPLRS mount (1) to EPLRS dual mount upper half (2) with four screws (14), washers (16), lockwashers (13), and nuts (17).

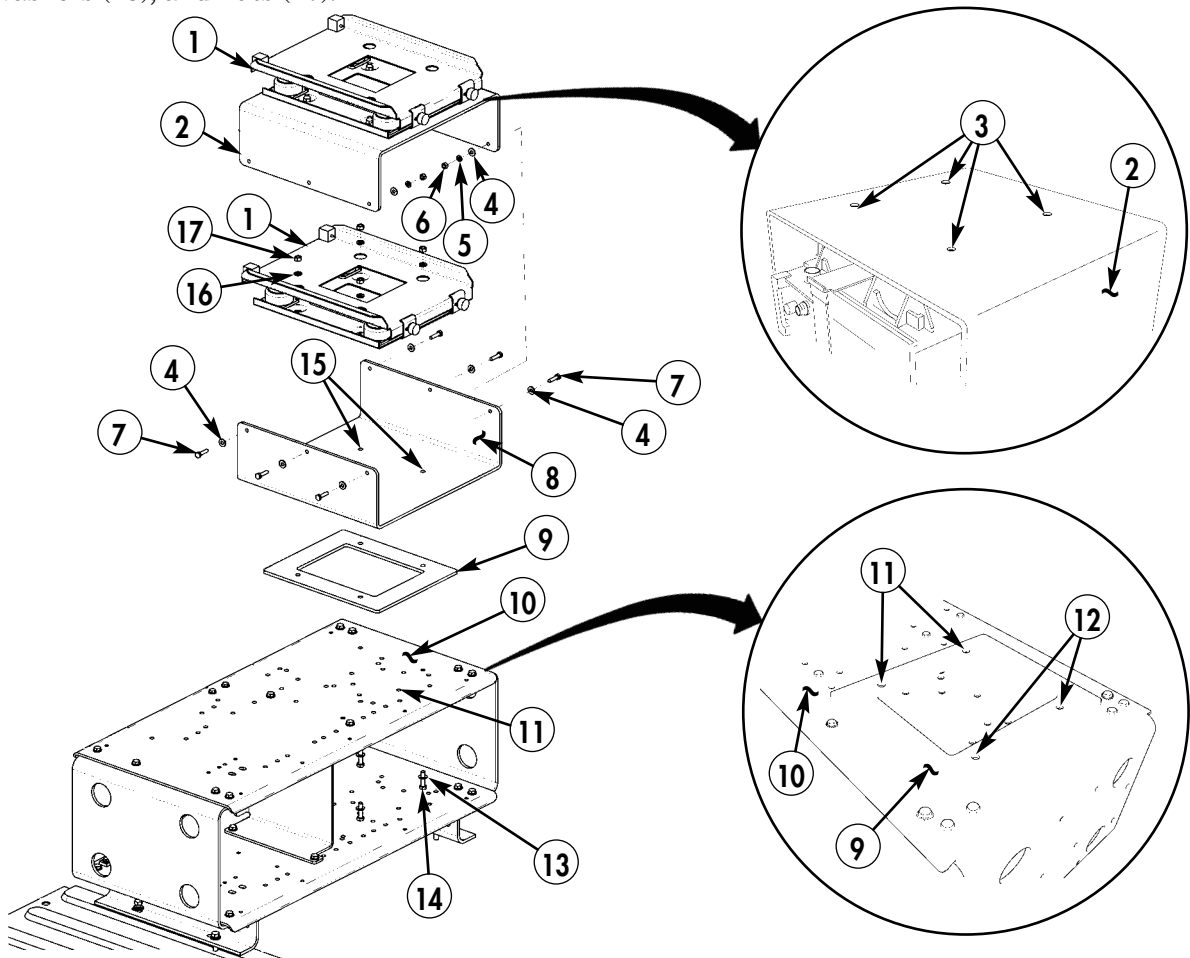

- | | |
|---|--------------------------------------|
| 1. MOUNT, RESILIENT – MT- 6146/VSQ-1 – QTY. 2 | 8. LOWER BASE – A3265624 – QTY. 1 |
| 2. UPPER BASE – A3265626 – QTY. 1 | 9. SPACER PLATE – A3265625 – QTY. 1 |
| 4. WASHER – MS27183-10 – QTY. 12 | 13. WASHER – MS27183-12 – QTY. 8 |
| 5. LOCKWASHER – MS35338-44 – QTY. 6 | 14. SCREW – MS90725-36 – QTY. 8 |
| 6. NUT – MS51967-2 – QTY. 6 | 15. LOCKWASHER – MS35338-45 – QTY. 8 |
| 7. SCREW – MS90725-8 – QTY. 6 | 16. NUT – MS51967-5 – QTY. 8 |

Figure 5-40.

Section XVII. PRINTER INSTALLATION

17-1. Remove and discard three existing screws (2), washers (4), lockwashers (3), and nuts (5) from multi-net rack (1).

17-2. Secure bottom mounting bracket (7) to printer mount assembly (6) with six existing screws (9) and washers (8).

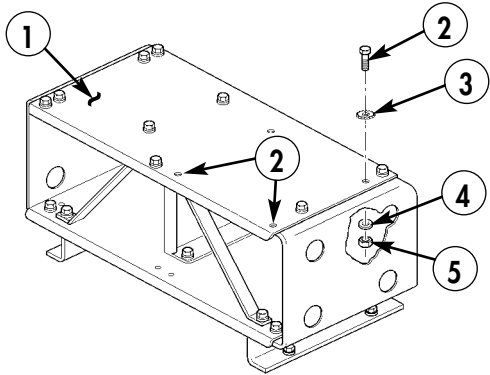
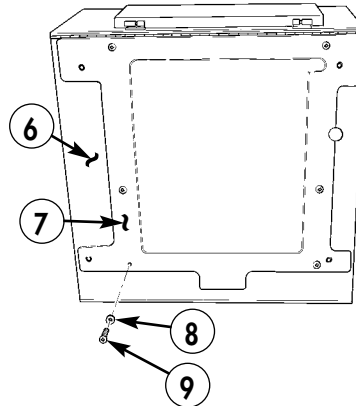

Figure 5-41.



- 6. PRINTER MOUNT ASSEMBLY – A3265640 – QTY. 1
- 7. BOTTOM MOUNTING BRACKET – P/O A3265640 – QTY. 1
- 8. WASHER – P/O 3265640 – QTY. 6
- 9. SCREW – P/O 3265640 – QTY. 6

Figure 5-42.

17-3. Install printer mount assembly (6) and mounting brackets (10) and (14) on multi-net rack (1) with three screws (12) and lockwashers (11), and screw (13) and lockwasher (11).

17-4. Secure printer mount assembly (6) to mounting brackets (10) and (14) with eight screws (17), lockwashers (16), and washers (15).

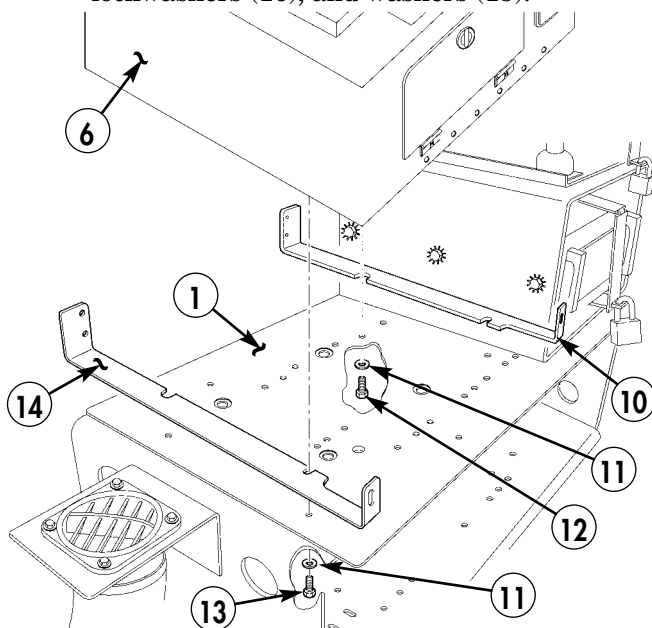

- 10. MOUNTING BRACKET – P/O A3265640 – QTY. 1
- 11. LOCKWASHER – MS45904-68 – QTY. 4
- 12. SCREW – MS90728-8 – QTY. 3
- 13. SCREW – MS90728-6 – QTY. 1
- 14. MOUNTING BRACKET – P/O A3265640 – QTY. 1

Figure 5-43.

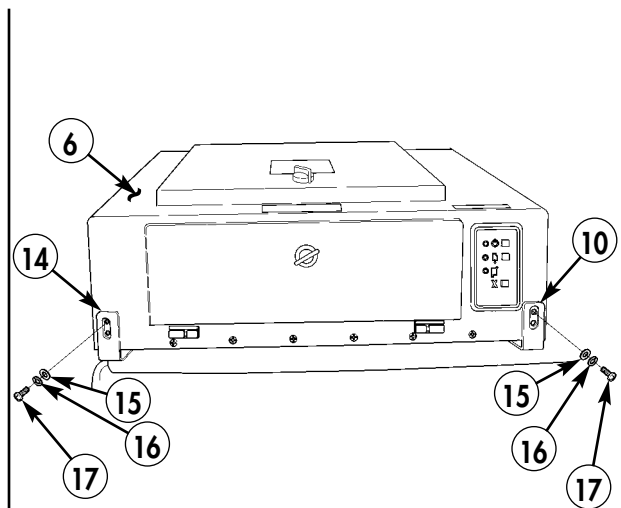

- 15. WASHER – MS27183-8 – QTY. 8
- 16. LOCKWASHER – MS35338-43 – QTY. 4
- 17. SCREW – MS35207-263 – QTY. 8

Figure 5-44.

17-5. Install ground strap (20) on printer mount assembly (6) and multi-net rack (1) with screw (21), existing wing nut (18), and lockwasher (19).

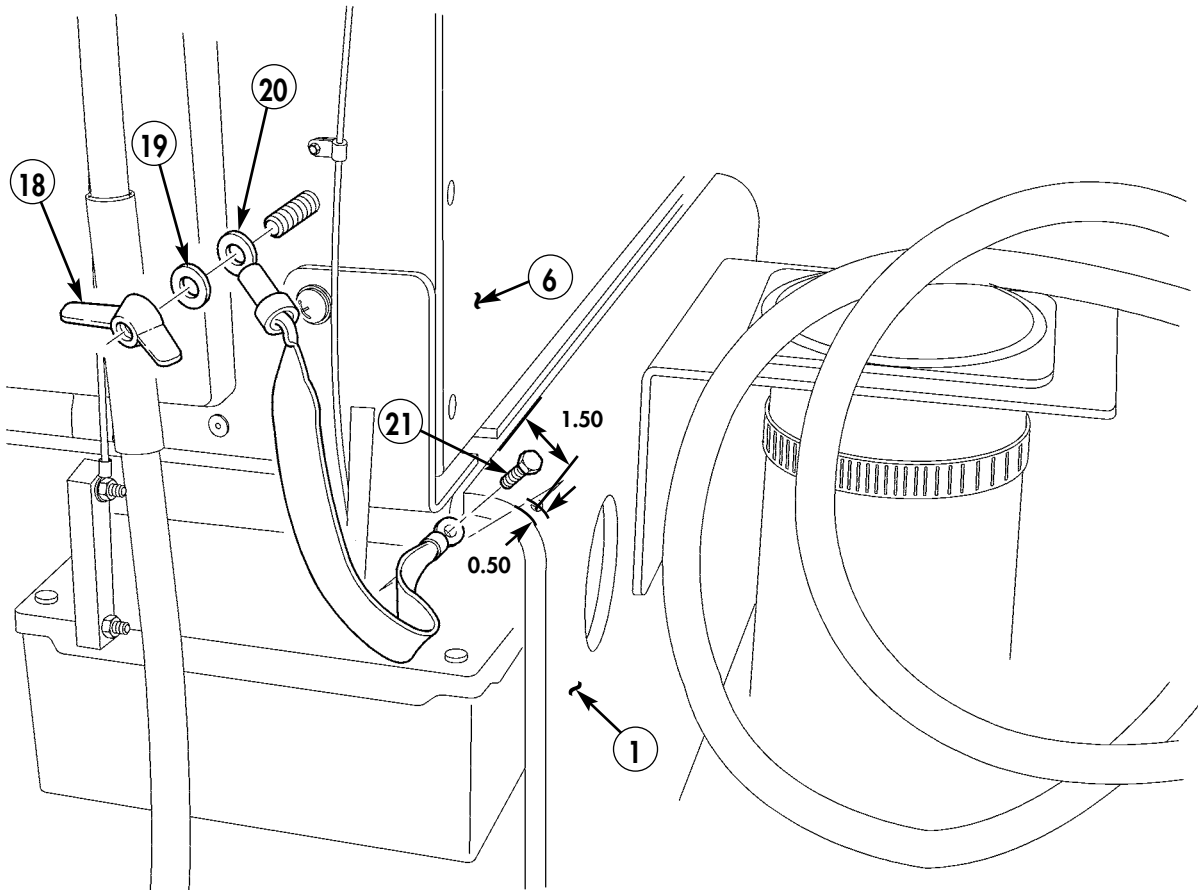

- 20. GROUND STRAP - 4801C3SG02 - QTY. 1
- 21. SCREW - 9421073 - QTY. 1

Figure 5-45.

Section XVIII. KOK-13 CRYPTO GENERATOR INSTALLATION

- 18-1. Locate, mark, and drill one 0.281-in. diameter hole (5) in KOK-13 mount support bracket (6).
- 18-2. Using KOK-13 mounting bracket (1) as template, locate, mark, and drill four 0.343-in. diameter holes (9) in multi-net lower shelf (2).
- 18-3. Attach KOK-13 mounting plate (1) to multi-net rack lower shelf (2) with four screws (3), eight washers (4), four lockwashers (7), and four nuts (8).

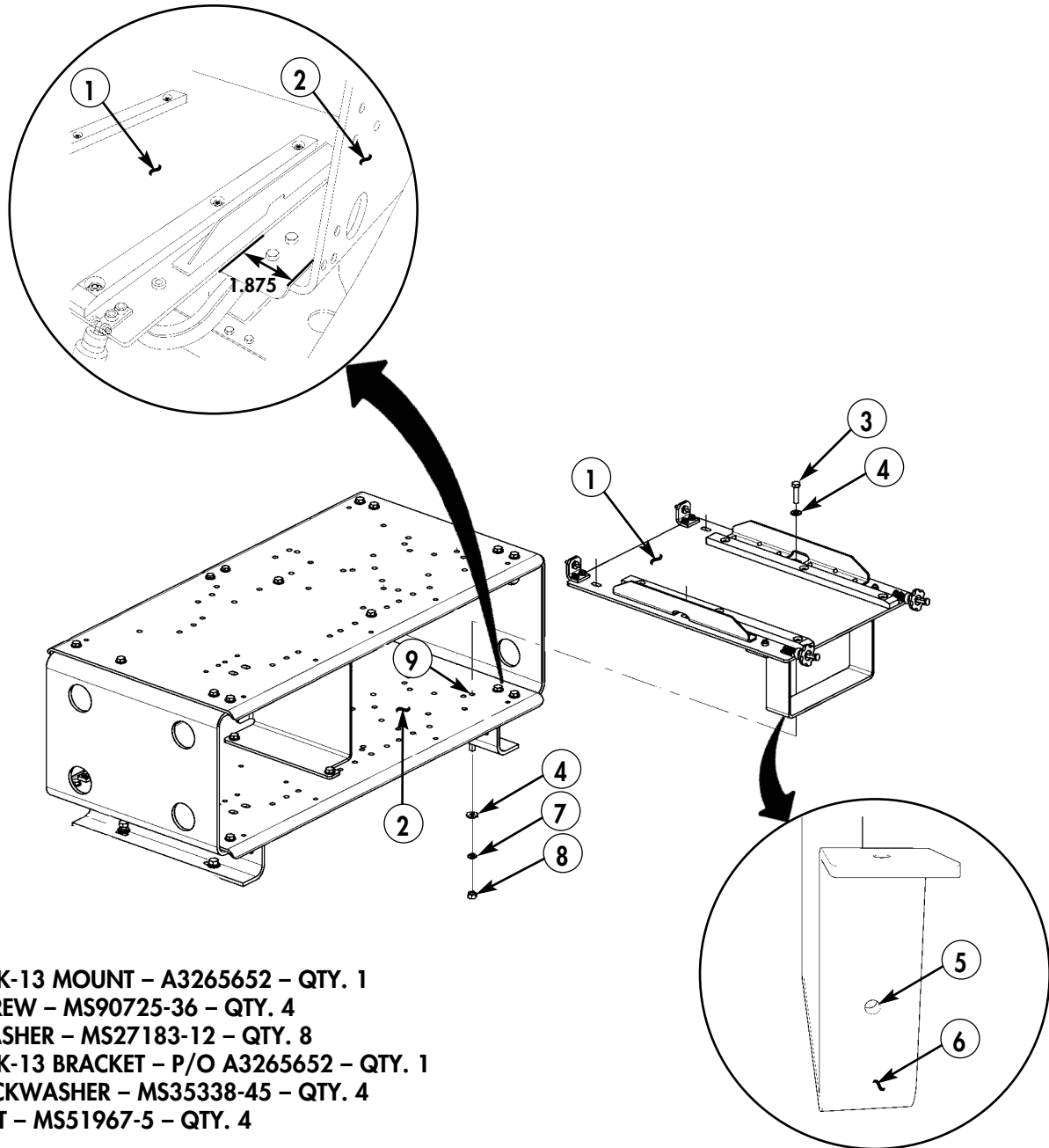

Figure 5-46.

Section XIX. BATTERY ALARM BOX INSTALLATION

- 19-1. Using battery alarm box as template, locate, mark, and drill four 0.281-in. diameter holes (1) in multi-net rack (2) lower shelf.
- 19-2. Install battery alarm box (3) on multi-net rack (2) lower shelf with four screws (4), eight washers (5), four lockwashers (6), and four nuts (7).

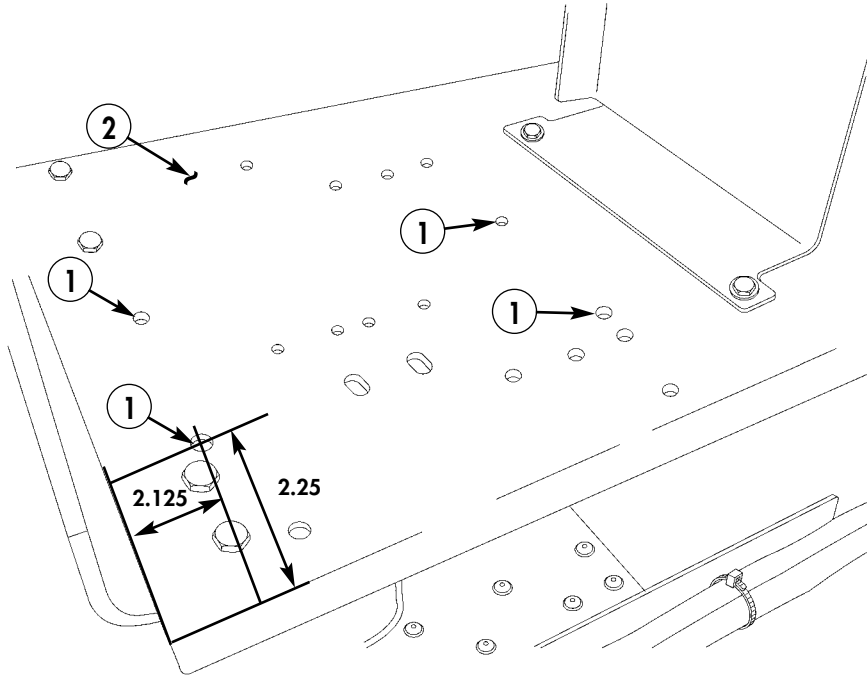
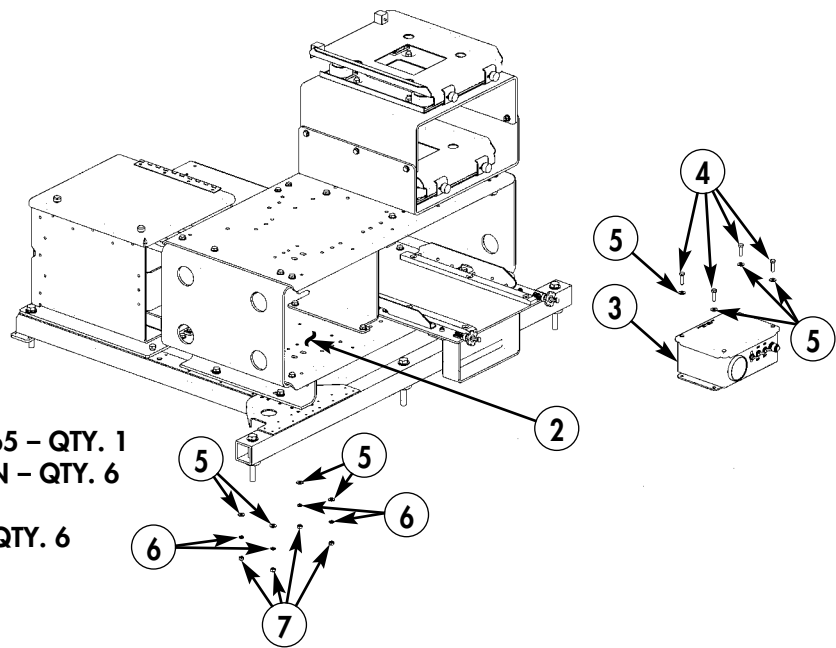

Figure 5-47.



- 3. BATTERY ALARM BOX - A3265665 - QTY. 1
- 4. CAPSCREW - B1821BH025C125N - QTY. 6
- 5. WASHER - 2436161 - QTY. 12
- 6. LOCKWASHER - MS35338-44 - QTY. 6
- 7. NUT - 9419143 - QTY. 6

Figure 5-48.

Section XX. INVERTER INSTALLATION

20-1. Locate, mark, and drill one 0.147-in. diameter hole (2) in multi-net rack (1).

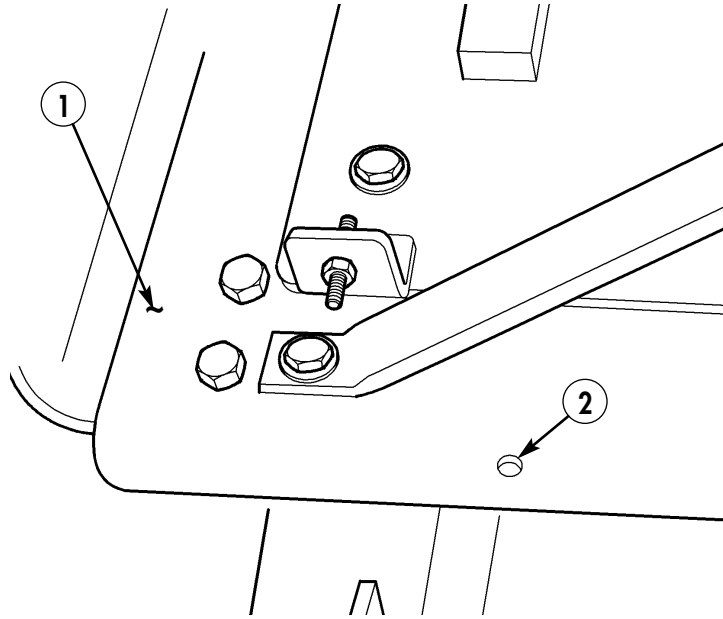
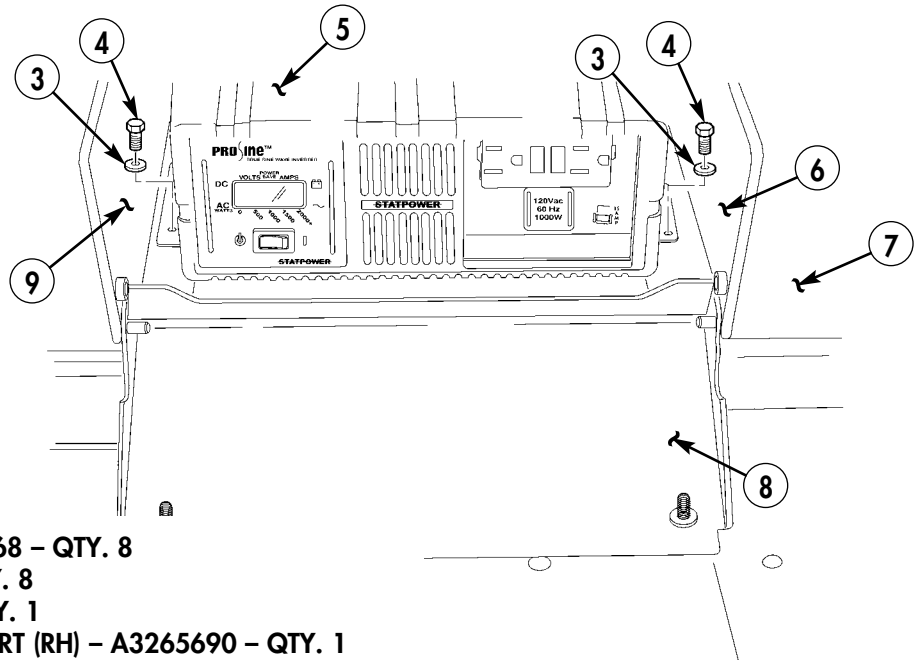

Figure 5-49.

20-2. Install inverter (5) on mounting plate (7) with eight screws (4), eight lockwashers (3), right-side inverter box plate (6), and left-side inverter box plate (9). Do not tighten screws at this time.

20-3. Install inverter box front plate (8) by inserting inverter box side plate (6) and (9) hinge pins into slots in inverter box front plate (8) and tightening all screws.



- 3. LOCKWASHER – MS45904-68 – QTY. 8
- 4. SCREW – MS90725-8 – QTY. 8
- 5. INVERTER – 806-1050 – QTY. 1
- 6. INVERTER HOUSING SUPPORT (RH) – A3265690 – QTY. 1
- 8. FRONT COVER PLATE – A3265693 – QTY. 1
- 9. INVERTER HOUSING SUPPORT (LH) – P/O A3265690 – QTY. 1

Figure 5-50.

20-4. Install inverter top plate (10) on inverter side plates (6) and (9) with four screws (11) and lockwashers (3).

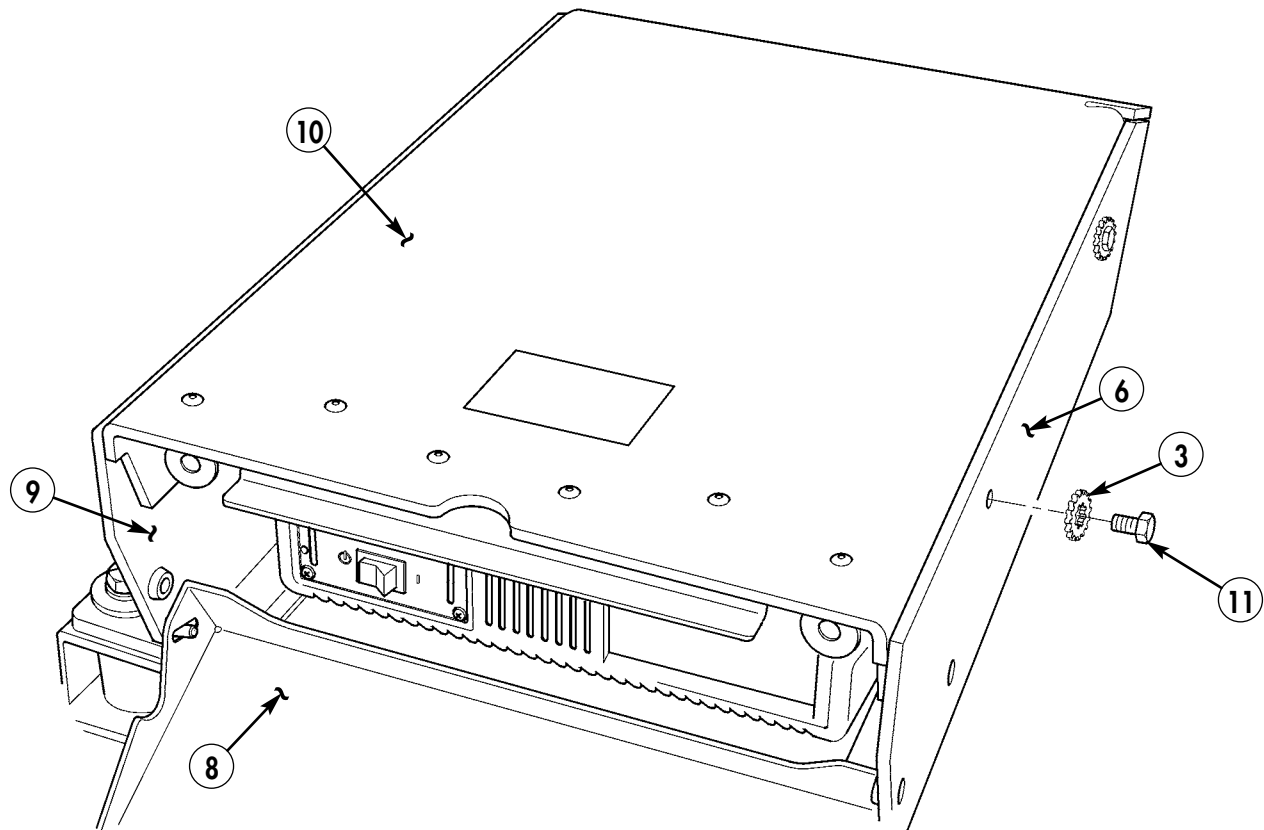

- 3. LOCKWASHER – MS45904-68 – QTY. 4
- 10. INVERTER TOP PLATE – A3265691 – QTY. 1
- 11. SCREW – MS90725-6 – QTY. 4

Figure 5-51.

Section XXI. REAR BATTERY BOX INSTALLATION

- 21-1.** Position carriage bolts (2) in rear battery tray (10).
- 21-2.** Install rear battery tray (10) and rear battery box (9) on mounting plate (8) with four screws (1).
- 21-3.** Install rear battery (3) in rear battery tray (10).
- 21-4.** Secure rear battery (3) to rear battery tray (10) with channel hold down (4), two washers (5), lockwashers (6), and nuts (7).

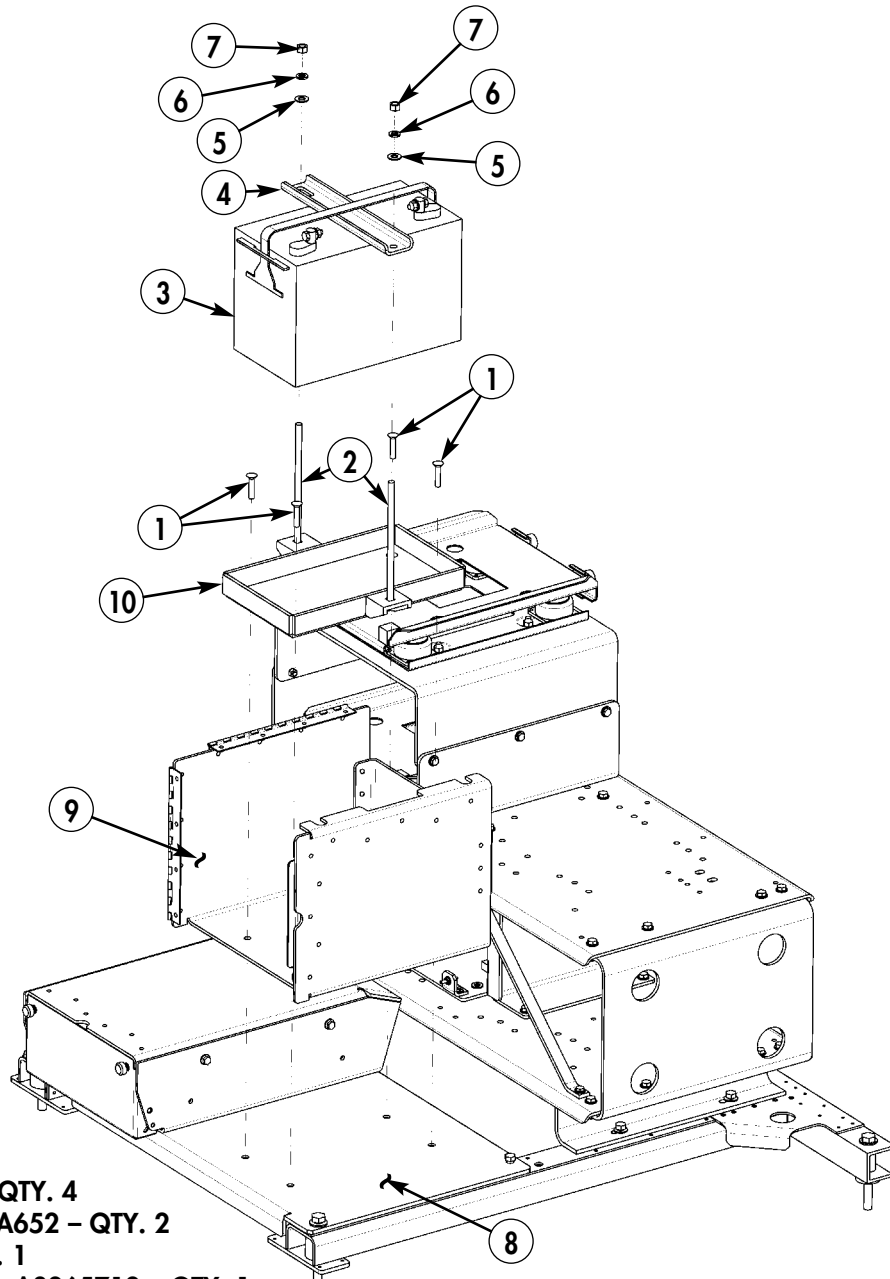

1. SCREW – MS24671-43 – QTY. 4
2. BOLT CARRIAGE – 93548A652 – QTY. 2
3. BATTERY – 8A27M – QTY. 1
4. CHANNEL HOLD DOWN – A3265712 – QTY. 1
5. WASHER – MS27183-14 – QTY. 2
6. LOCKWASHER – MS35338-46 – QTY. 2
7. NUT – MS51967-8 – QTY. 2
9. BATTERY BOX – A3265709 – QTY. 1
10. BATTERY TRAY – A3265708 – QTY. 1

Figure 5-52.

Section XXII. AC DISTRIBUTION BOX INSTALLATION

- 22-1.** Using AC distribution box (5) as template, locate, mark, and drill four 0.281-in. diameter holes (8) in left rear wheelhouse (4).
- 22-2.** Secure AC distribution box (5) to left rear wheelhouse (4) with four screws (7), washers (6), fender washers (3), lockwashers (2), and nuts (1).

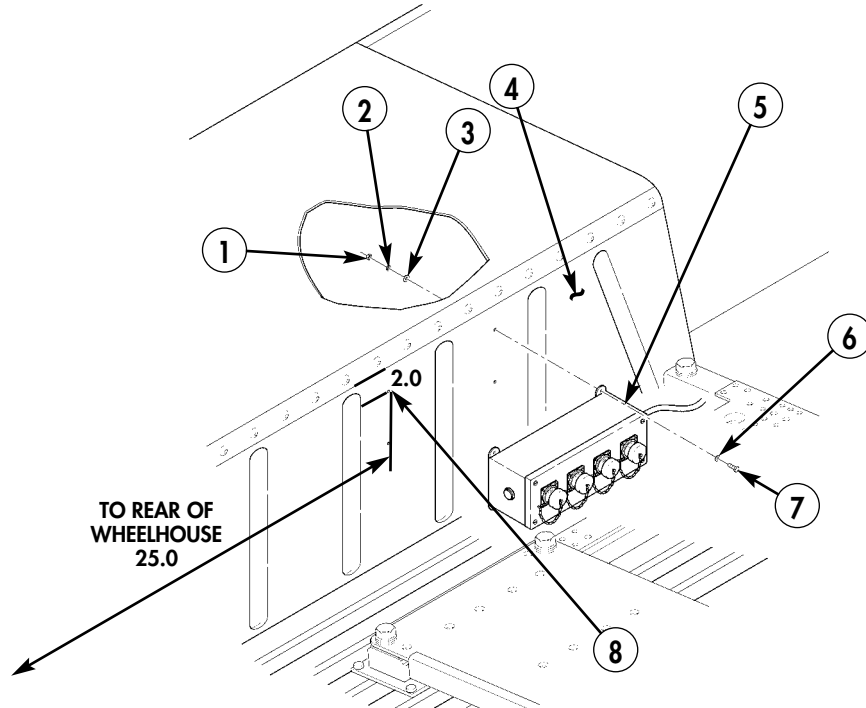

- 1. NUT – MS51967-2 – QTY. 4
- 2. LOCKWASHER – MS35338-44 – QTY. 4
- 3. FENDER WASHER – 6001001 – QTY. 4
- 5. AC DISTRIBUTION BOX– A3265676 – QTY. 1
- 6. WASHER – 2436161 – QTY. 4
- 7. SCREW – B1821BH025C100N – QTY. 4

Figure 5-53.

Section XXIII. AC OUTPUT SELECTION BOX INSTALLATION

- 23-1.** Using AC output selection box (5) as template, locate, mark, and drill four 0.313-in. diameter holes (4) in left rear wheelhouse (8).
- 23-2.** Secure AC output selection box (5) to left rear wheelhouse (8) with four screws (6), washers (7), fender washers (3), lockwashers (2), and nuts (1).

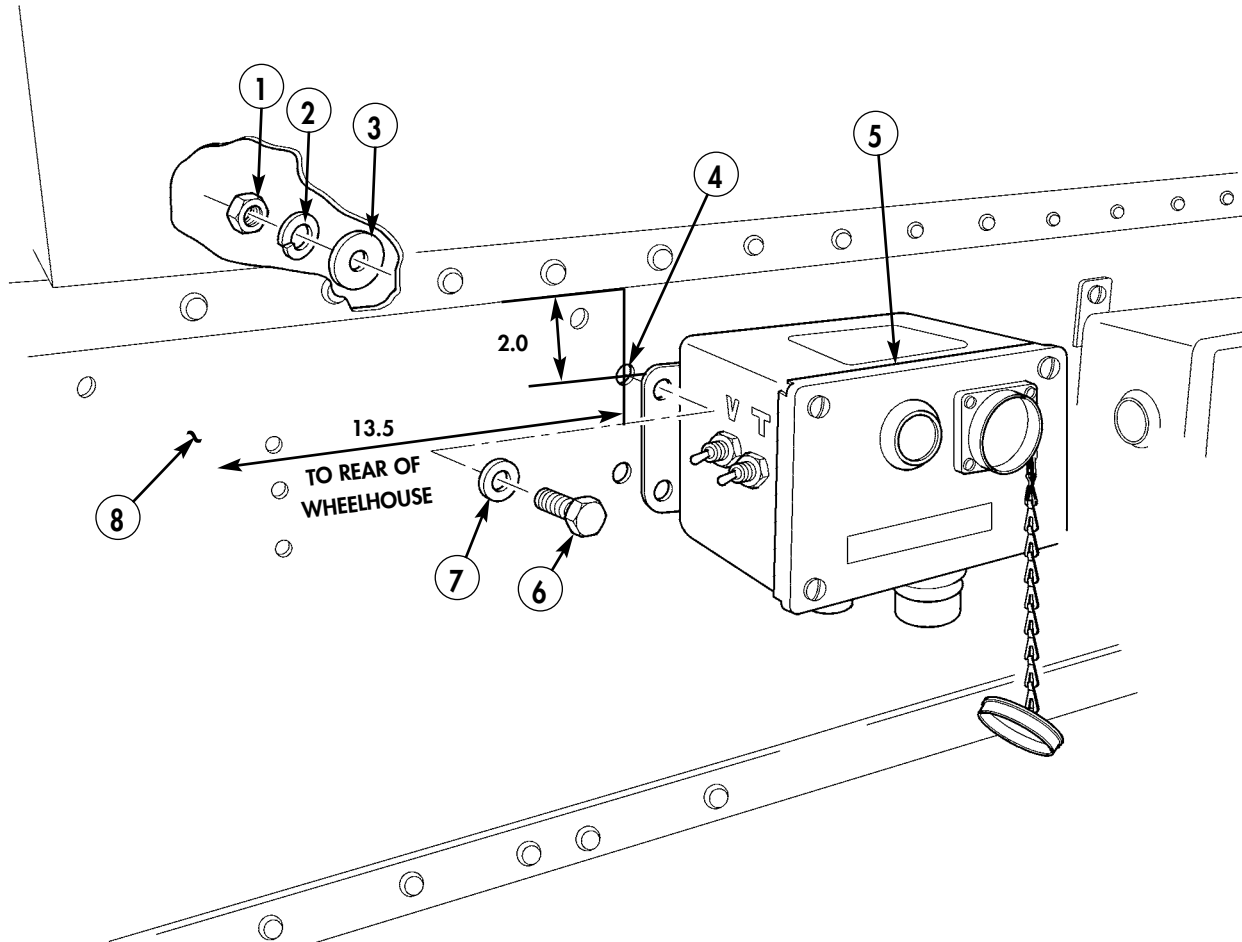

1. NUT – MS51967-6 – QTY. 4
2. LOCKWASHER – MS35338-45 – QTY. 4
3. FENDER WASHER – 90313A112 – QTY. 4
5. AC OUTPUT SELECTION BOX – A3265686 – QTY. 1
6. SCREW – B1821BH025C100N – QTY. 4
7. WASHER – 2436162 – QTY. 4

Figure 5-54.

Section XXIV. DC CHARGER INSTALLATION

- 24-1. Using DC charger (6) as template, locate, mark, and drill four 0.343-in. diameter holes (1) in left rear wheelhouse (2).
- 24-2. Using DC charger guard (12) as template, locate, mark, and drill four 0.281-in. diameter holes (3) in left rear wheelhouse (2).
- 24-3. Modify one fender washer (4) by removing 0.50-in. (5) from one side.

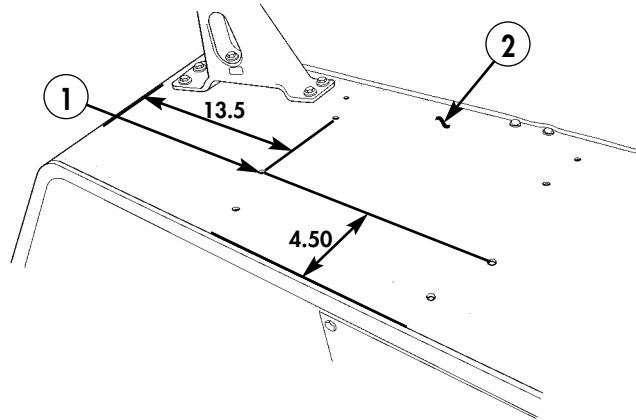

Figure 5-55.

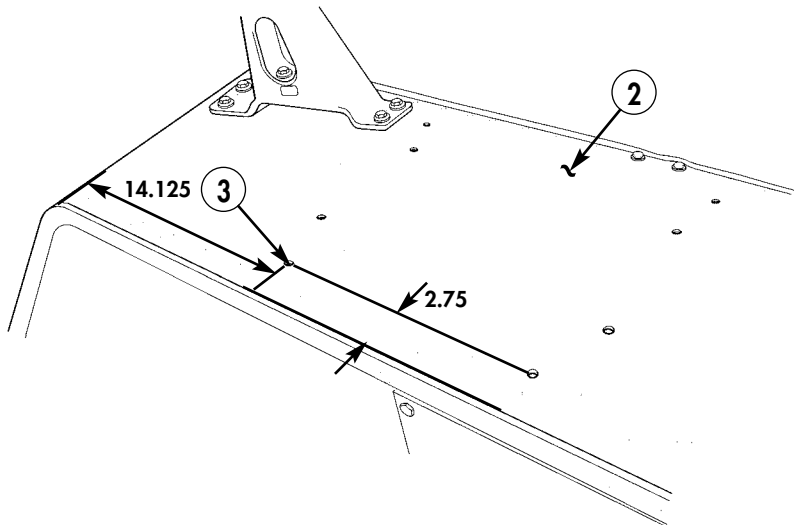
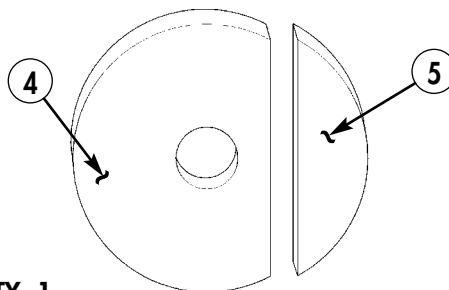

Figure 5-56.



4. FENDER WASHER - 9109A111 - QTY. 1

Figure 5-57.

24-4. Install DC charger (6) on left rear wheelhouse (2) with four screws (7), washers (8), fender washers (9), lockwashers (10), and nuts (11).

24-5. Install DC charger guard (12) on left rear wheelhouse (2) with four screws (13), lockwashers (16), washers (14), fender washers (15), and nuts (17).

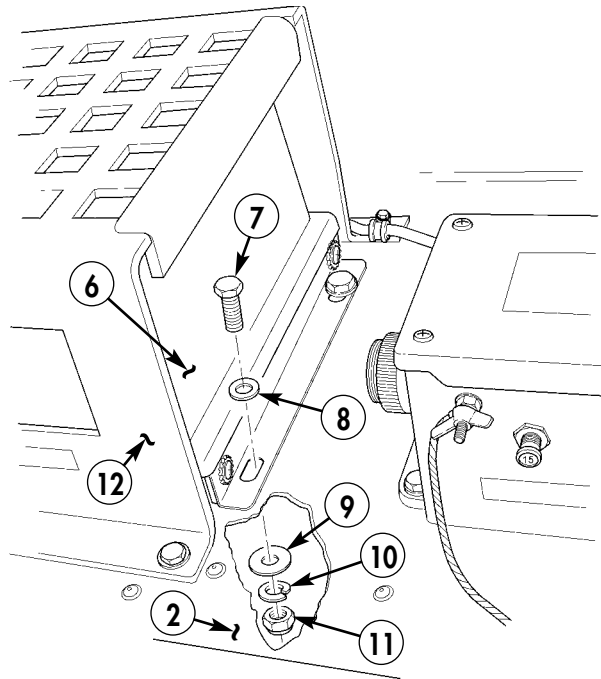

- 6. DC CHARGER – 93-WP40-A – QTY. 1
- 7. SCREW – B1821BH031C100N – QTY. 4
- 8. WASHER – 2436162 – QTY. 4
- 9. FENDER WASHER – 9109A111 – QTY. 4
- 10. LOCKWASHER – MS35338-45 – QTY. 4
- 11. NUT – 9417954- QTY. 4

Figure 5-58.

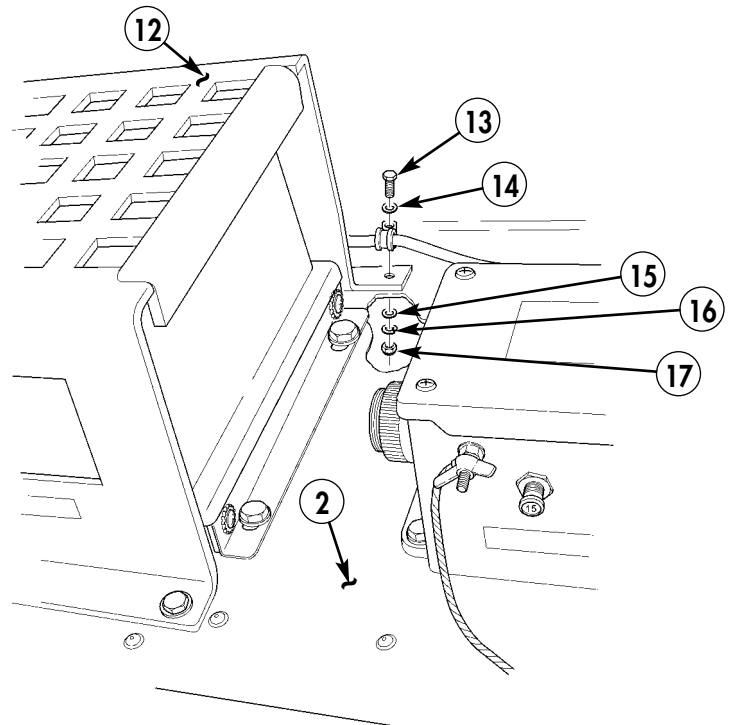

- 12. DC CHARGER GUARD – A3265713 – QTY. 1
- 13. SCREW – B1821BH025C100N – QTY. 4
- 14. WASHER – 2436161 – QTY. 4
- 15. FENDER WASHER – 9109A111 – QTY. 4
- 16. LOCKWASHER – MS45904-68 – QTY. 4
- 17. NUT – 9419143- QTY. 4

Figure 5-59.

Section XXV. EXTERNAL POWER RECEPTION BOX INSTALLATION

- 25-1. Locate, mark, and drill one 0.147-in. diameter hole (1) in right rear wheelhouse (2).
- 25-2. Using external power reception box (4) as template, locate, mark, and drill four 0.343-in. diameter holes (3) in right rear wheelhouse (2).

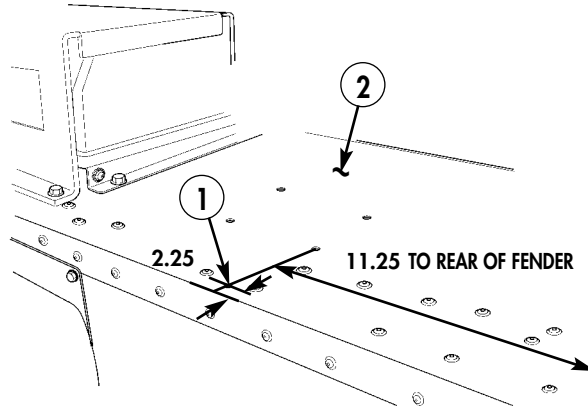

Figure 5-60.

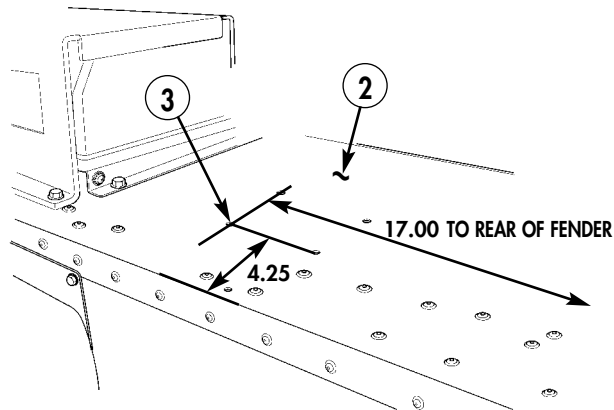
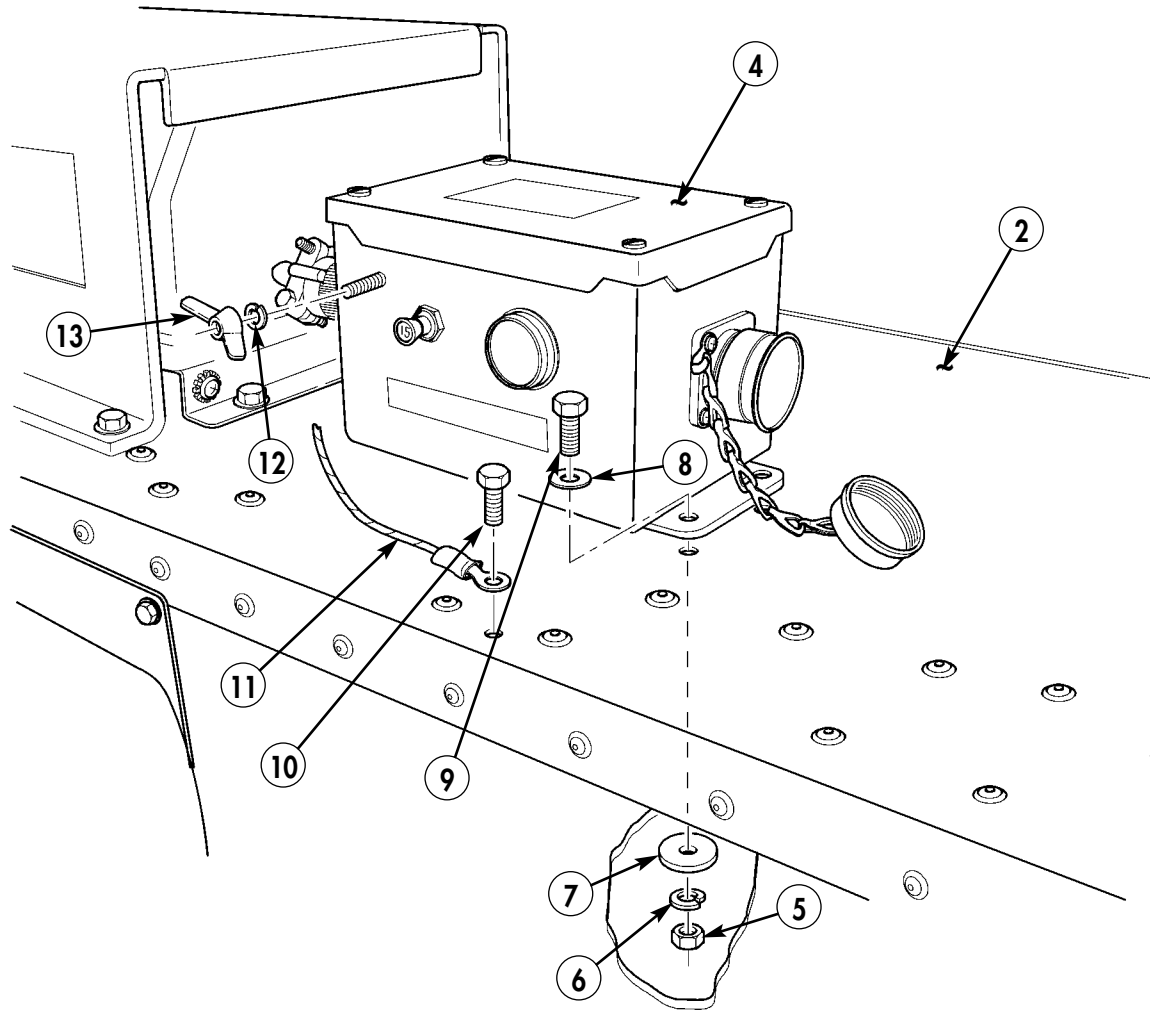

Figure 5-61.

- 25-3.** Install external power reception box (4) on right rear wheelhouse (2) with four screws (9), washers (8), fender washers (7), lockwashers (6), and nuts (5).
- 25-4.** Connect ground strap (11) to external power reception box (4) with existing wingnut (13) and lockwasher (12).
- 25-5.** Connect ground strap (11) to right rear wheelhouse (2) with screw (10).



- 4.** BOX, EXTERNAL POWER RECEPTION – A3265660 – QTY. 1
5. NUT – 9417954 – QTY. 4
6. LOCKWASHER – MS35338-45 – QTY. 4
7. FENDER WASHER – 9109A111 – QTY. 4
8. WASHER – MS27183-12 – QTY. 4
9. SCREW – B1821BH031C100N – QTY. 4
10. SCREW, SELF-TAPPING – 9421073 – QTY. 1
11. STRAP, GROUND – 4801C3SG02 – QTY. 1

Figure 5-62.

Section XXVI. EPLRS ANTENNA INSTALLATION

- 26-1. Install grommet (10) on antenna bracket (5).
- 26-2. Position antenna (1) and gasket (4) on antenna mounting bracket (5).
- 26-3. Install antenna (1) and gasket (4) on antenna mounting bracket (5) with four capscrews (2), eight lockwashers (3), and four nuts (6).
- 26-4. Install antenna mounting bracket (5) on fiberglass body (9) with three capscrews (7), six lockwashers (3), and three nuts (8).
- 26-5. Repeat steps 26-1 through 26-4 for left-hand side.

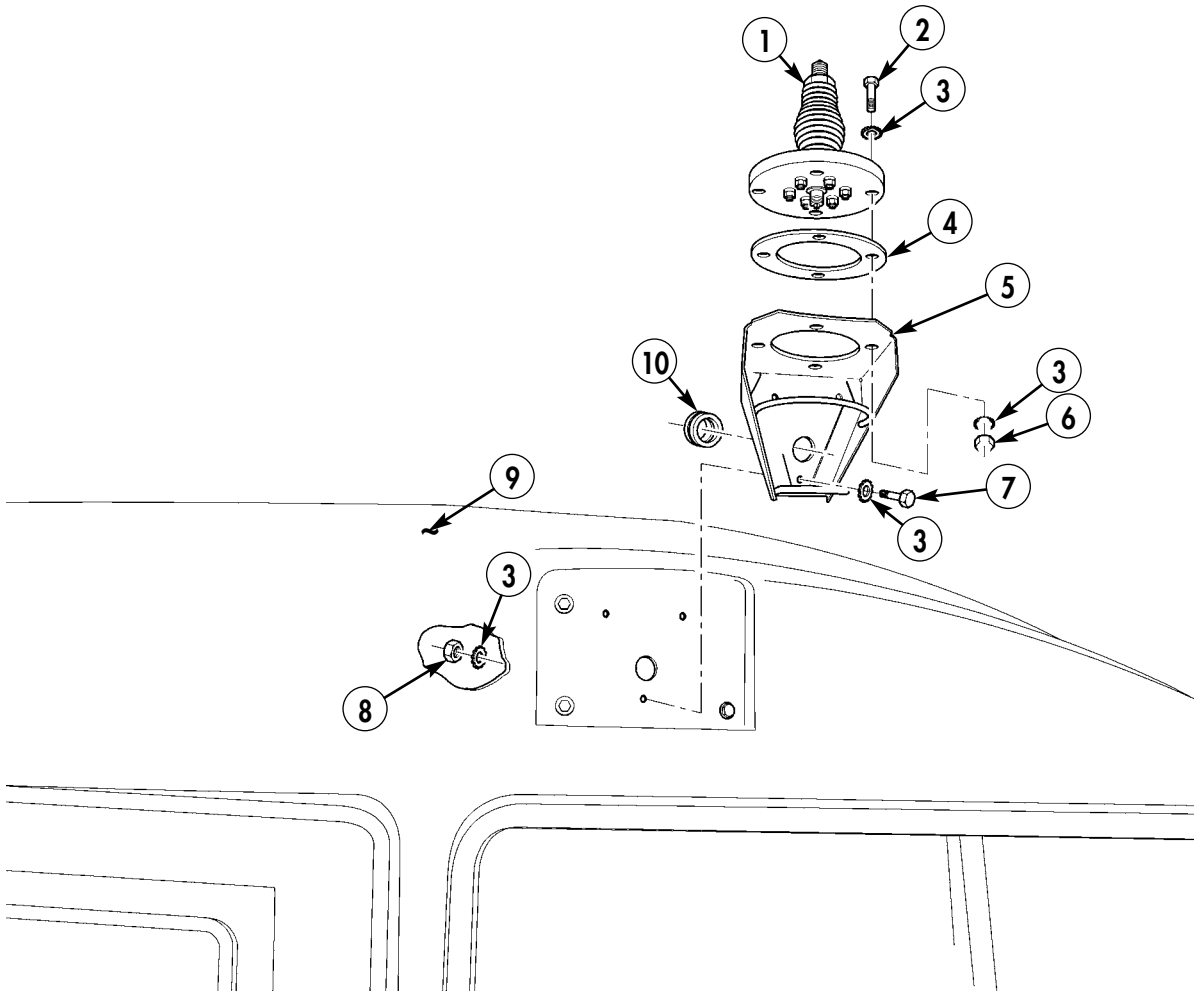

- 1. ANTENNA – A3005031 – QTY. 2
- 2. CAPSCREW – MS35307-365 – QTY. 3
- 3. LOCKWASHER – MS45904-72 – QTY. 28
- 4. GASKET – A3013655-1 – QTY. 2
- 5. ANTENNA MOUNTING BRACKET – A3014546-1 – QTY. 2
- 6. NUT – 13218E0320-293 – QTY. 8
- 7. CAPSCREW – B1821BH031F125N – QTY. 6
- 8. NUT – 9418892 – QTY. 6
- 10. GROMMET – 12338098 – QTY. 2

Figure 5-63.

Section XXVII. LEFT-SIDE SINGARS ANTENNA MOUNT INSTALLATION

27-1. Install angle plate (1) on antenna support (2) with four screws (6), eight washers (5), four lockwashers (4), and four nuts (3).

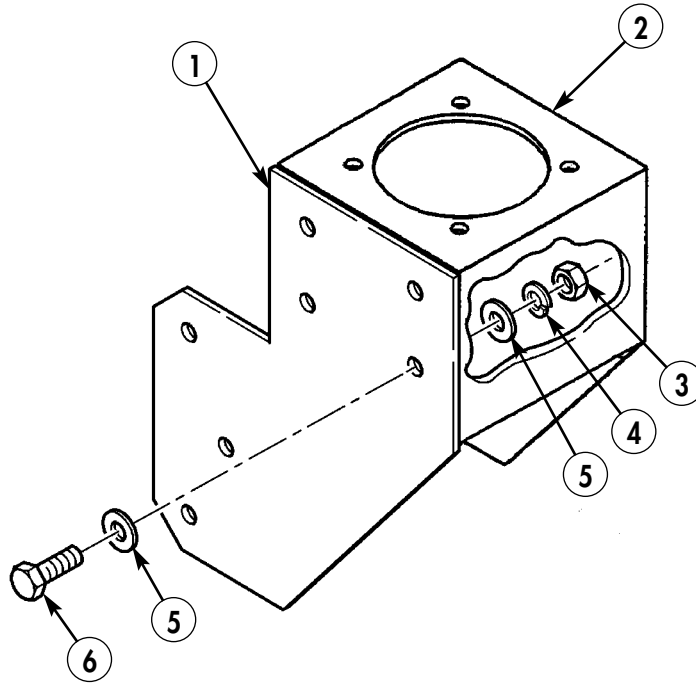

1. PLATE (ANGLED) – A3103740 – QTY. 1
2. ANTENNA SUPPORT – A3103782 – QTY. 1
3. NUT – MS35690-610 – QTY. 4
4. LOCKWASHER – MS35338-141 – QTY. 4
5. WASHER – MS15795-814 – QTY. 8
6. SCREW – MS90725-64 – QTY. 4

Figure 5-64.

27-2. Using angle plate (1) as template, locate, mark, and drill three 0.406-in. diameter holes on left-side rear wheelhouse (7).

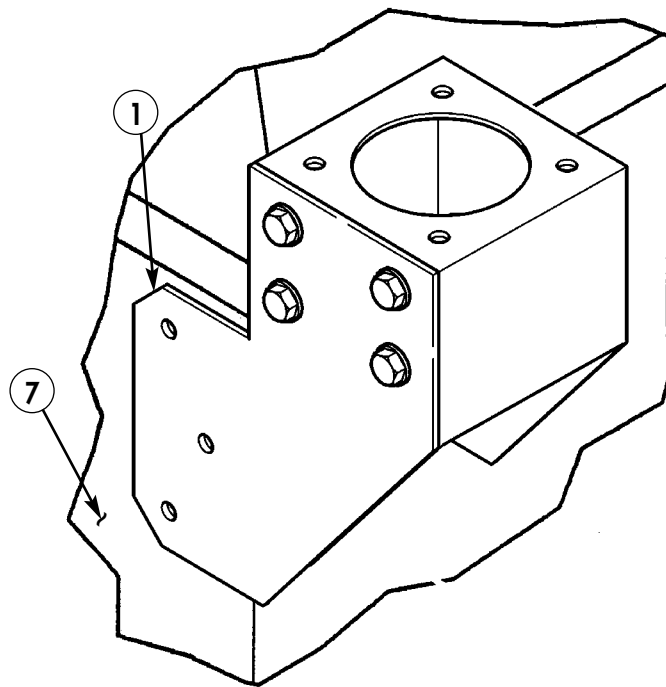
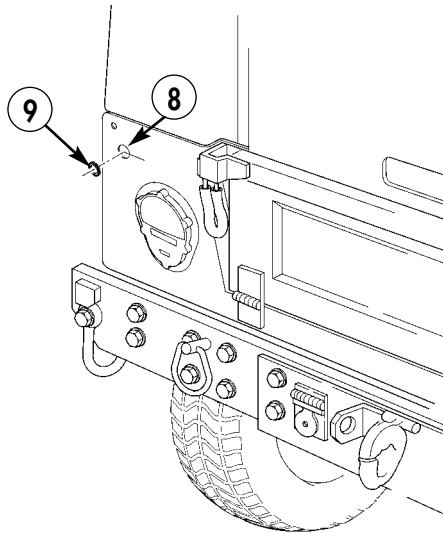

Figure 5-65.

- 27-3. Install 4.250-in. piece of plastic-edge grommet (9) in hole (8) in left-side rear wheelhouse (7).
- 27-4. Temporarily secure antenna support (2) and angle plate (1) to left side of rear wheelhouse (7) with three screws (6) and three nuts (3).
- 27-5. Using antenna support (2) as template, locate, mark and drill two 0.406-in. diameter holes (10) on left-side rear wheelhouse (7).
- 27-6. Remove antenna support (2) and angle plate (1) from left-side rear wheelhouse (7).



9. GROMMET – MS21266-4N – QTY. A/R

Figure 5-66.

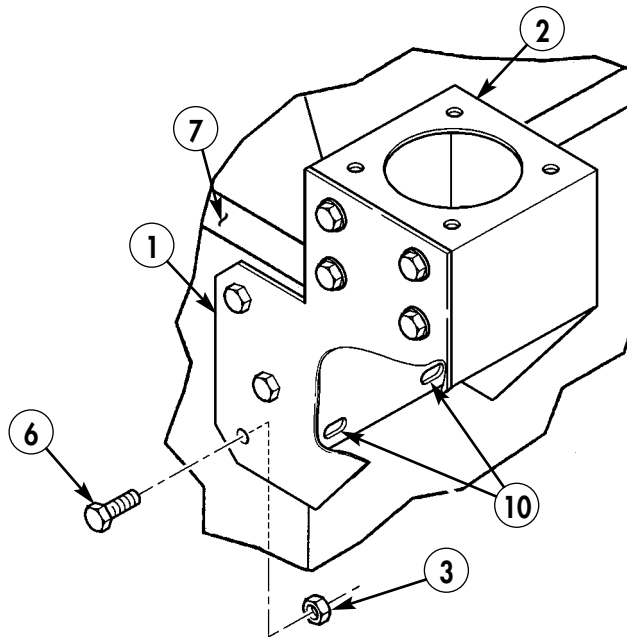

3. NUT – MS35690-610 – QTY. 3
 6. SCREW – MS90725-64 – QTY. 3

Figure 5-67.

- 27-7. Install 4.250-in. piece of plastic-edge grommet (9) in hole (11) of antenna bracket (2).
- 27-8. Secure angle plate (1) and antenna support (2) to left side of rear wheelhouse (7) with backing plate (13), three screws (6), six washers (5), three lockwashers (4), and three nuts (3).
- 27-9. Secure antenna support (2) to left side of rear wheelhouse (7) with plate (12), two screws (6), four washers (5), two lockwashers (4), and two nuts (3).

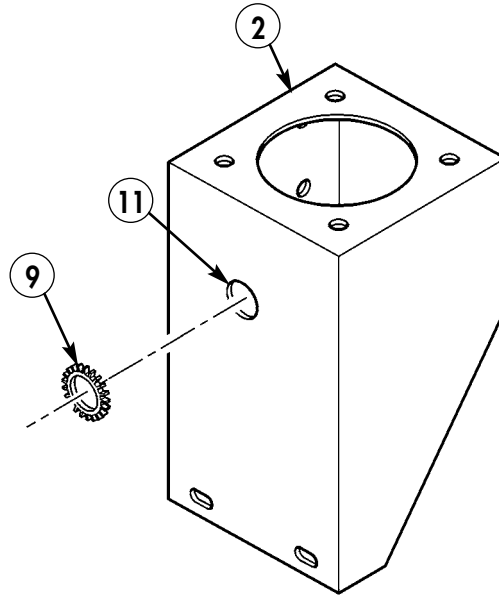

9. GROMMET – MS21266-4N – QTY. A/R

Figure 5-68.

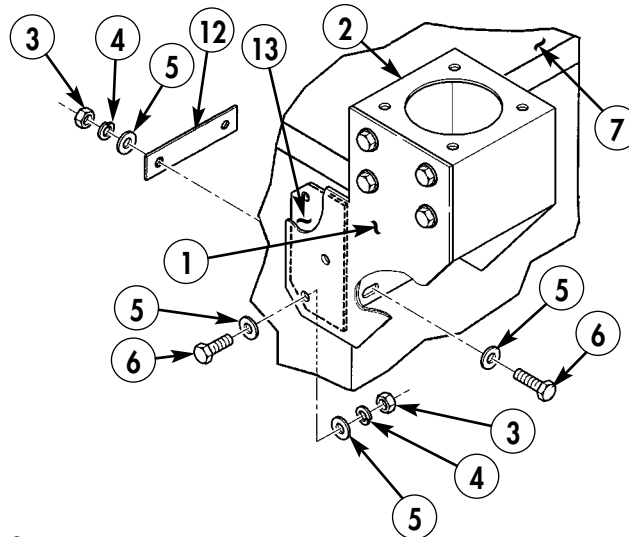

- 3. NUT – MS35690-610 – QTY. 2
- 4. LOCKWASHER – MS35338-141 – QTY. 5
- 5. WASHER – MS15795-814 – QTY. 10
- 6. SCREW – MS90725-64 – QTY. 2
- 12. PLATE – A3103784 – QTY. 1
- 13. BACKING PLATE – A3046222 – QTY. 1

Figure 5-69.

- 27-10.** Install upper half of antenna offset mount (15) on lower half of antenna mount (2) with four screws (16), eight washers (5), four lockwashers (4), and four nuts (3).

NOTE

Ensure holes in antenna base and grommet are aligned with weldnut holes in mounting bracket.

- 27-11.** Install antenna (22) and gasket (21) on top of antenna offset mount (15) with four screws (14), lockwashers (24), and washers (23).

NOTE

Prior to securing antenna ground lead, enlarge hole on offset mount with 9/32-in. drill bit to allow 1/4-in. screw to fit.

- 27-12.** Secure antenna ground lead (19) to lower half of antenna mount (2) with screw (17), two lockwashers (18), and nut (20).

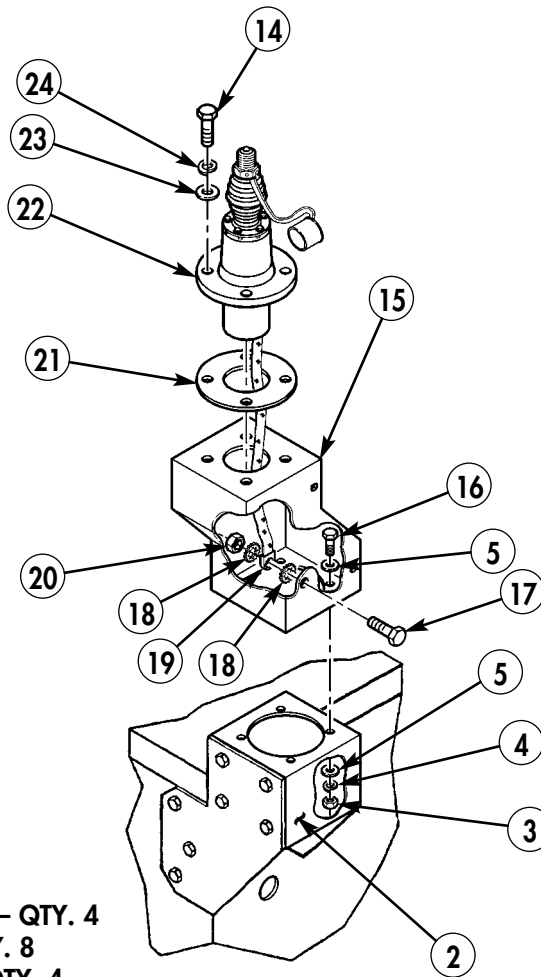

- 3. NUT – MS35690-610 – QTY. 4
- 4. LOCKWASHER – MS35338-141 – QTY. 4
- 5. WASHER – MS15795-814 – QTY. 8
- 14. CAPSCREW – MS35307-365 – QTY. 4
- 15. OFFSET MOUNT – A3046219 – QTY. 1
- 16. SCREW – MS90725-62 – QTY. 4
- 17. SCREW – MS35207-263 – QTY. 1
- 18. LOCKWASHER – MS45904-68 – QTY. 2
- 20. NUT – MS35650-302 – QTY. 1
- 21. GASKET – A3013655-1 – QTY. 1
- 22. ANTENNA – A3017889-2 – QTY. 1
- 23. WASHER – 2436163 – QTY. 4
- 24. LOCKWASHER – MS45904-72 – QTY. 4

Figure 5-70.

- 27-13. Attach upper antenna element (25) to lower antenna element (27).
- 27-14. Attach antenna assembly to antenna base (22).
- 27-15. Attach fiber rope assembly (26) to upper antenna element (25).
- 27-16. Secure lower antenna element (27) to antenna base (22) with lockwire (28).

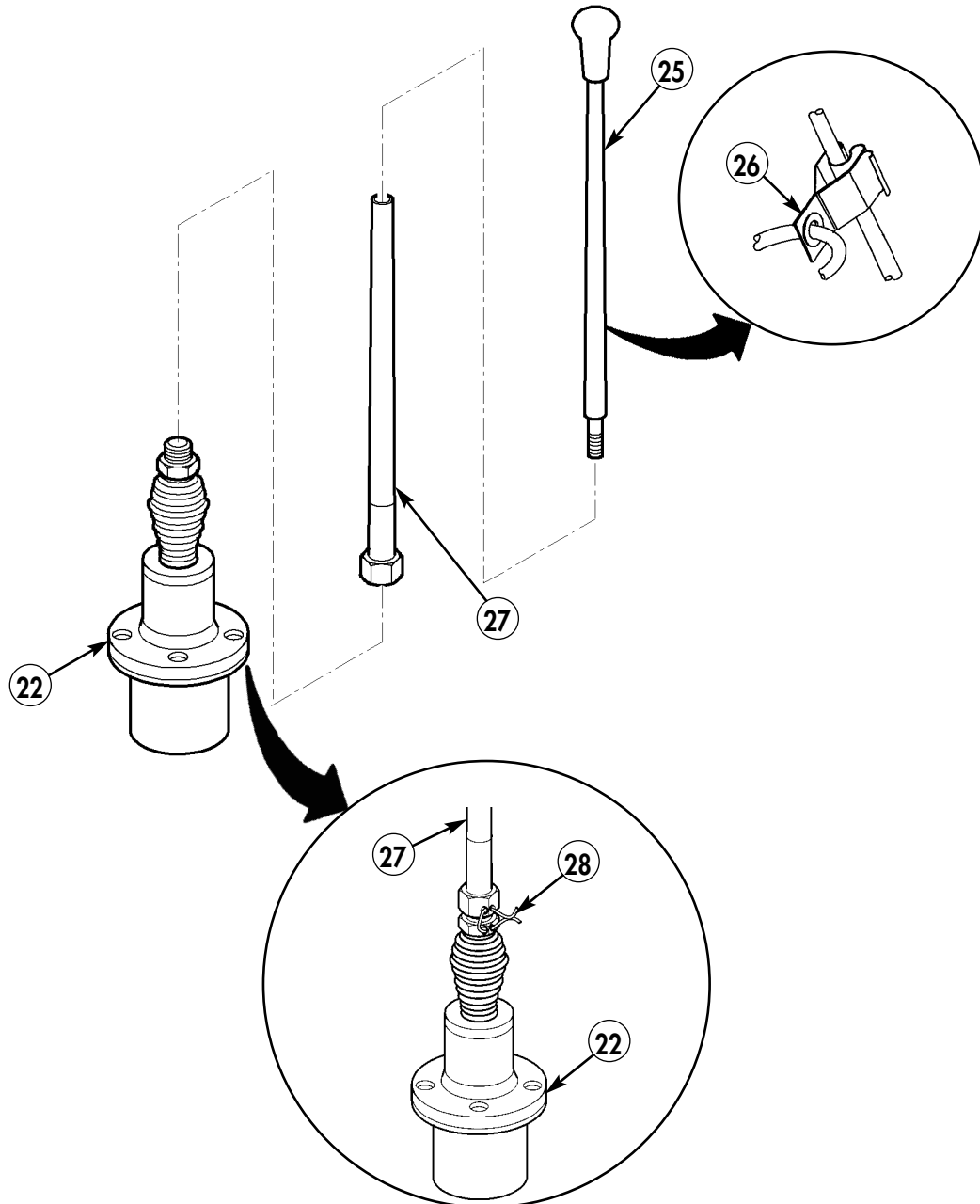

- 25. UPPER ANTENNA ELEMENT – A3017901-2 – QTY. 1
- 26. FIBER ROPE ASSEMBLY – A3167672-1 – QTY. 1
- 27. LOWER ANTENNA ELEMENT – A3018230-1 – QTY. 1
- 28. LOCKWIRE – MS20995C32 – QTY. A/R

Figure 5-71.

Section XXVIII. RIGHT-SIDE SINGARS ANTENNA INSTALLATION

28-1. Install angle plate (2) on antenna support (1) with four screws (4), eight washers (3), four lockwashers (5), and four nuts (6).

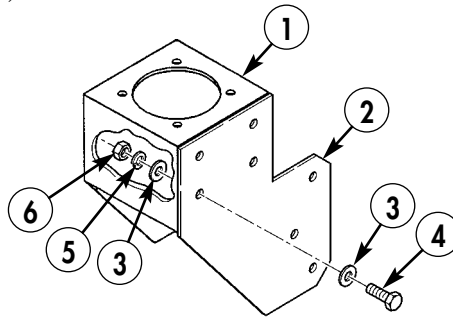

- | | |
|--|--------------------------------------|
| 1. ANTENNA SUPPORT – A3103782 – QTY. 1 | 4. SCREW – MS90725-64 – QTY. 4 |
| 2. PLATE (ANGLED) – A3103740 – QTY. 1 | 5. LOCKWASHER – MS35338-141 – QTY. 4 |
| 3. WASHER – MS15795-814 – QTY. 8 | 6. NUT – MS35690-610 – QTY. 4 |

Figure 5-72.

28-2. Using angle plate (2) as template, locate, mark, and drill three 0.406-in. diameter holes on right-side rear wheelhouse (7).

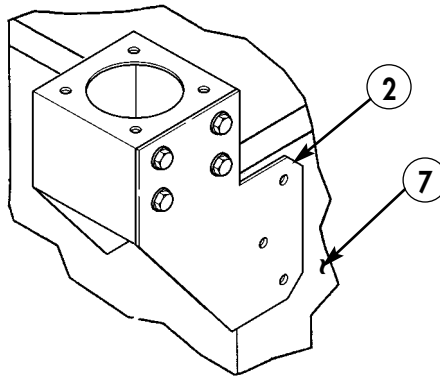
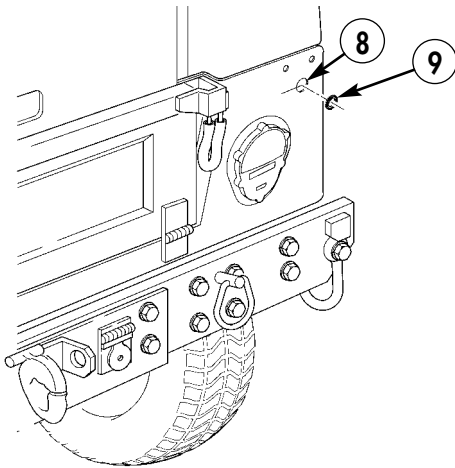

Figure 5-73.

- 28-3. Install 4.250-in. piece of plastic-edge grommet (9) in existing hole (8) of right-side rear wheelhouse (7).
- 28-4. Temporarily secure antenna support (1) and angle plate (2) to right-side rear wheelhouse (7) with three screws (4) and three nuts (6).
- 28-5. Using antenna support (1) as template, locate, mark, and drill two 0.406-in. diameter holes (10) in right-side rear wheelhouse (7).
- 28-6. Remove antenna support (1) and angle plate (2) from right-side rear wheelhouse (7).



9. GROMMET - MS21266-4N - QTY. A/R

Figure 5-74.

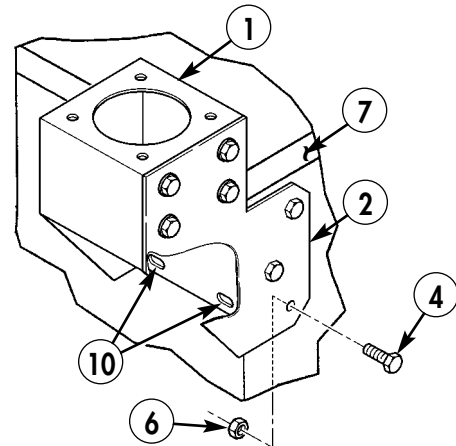

4. SCREW - MS90725-64 - QTY. 3
6. NUT - MS35690-610 - QTY. 3

Figure 5-75.

- 28-7. Install 4.250-in. piece of plastic-edge grommet (9) in hole (11) of antenna support (1).
- 28-8. Secure angle plate (2) and antenna support (1) to right-side rear wheelhouse (7) with backing plate (13), three screws (4), six washers (3), three lockwashers (5), and three nuts (6).
- 28-9. Secure antenna support (1) to right-side rear wheelhouse (7) with plate (12), two screws (4), four washers (3), two lockwashers (5), and two nuts (6).

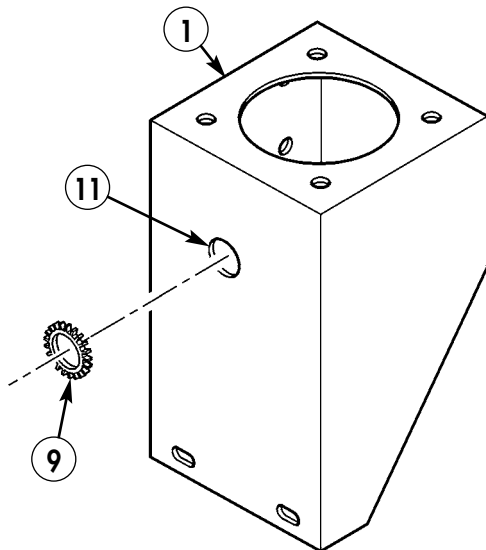

9. GROMMET - MS21266-4N - QTY. A/R

Figure 5-76.

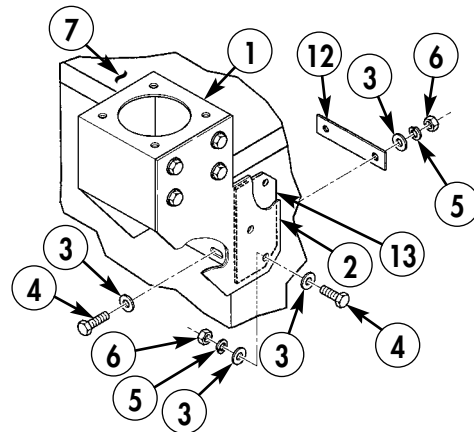

3. WASHER - MS15795-814 - QTY. 10
4. SCREW - MS90725-64 - QTY. 2
5. LOCKWASHER - MS35338-141 - QTY. 5
6. NUT - MS35690-610 - QTY. 2
12. PLATE - A3103784 - QTY. 1
13. BACKING PLATE - A3046222 - QTY. 1

Figure 5-77.

28-10. Install upper half of antenna offset mount (18) to antenna support (1) with four screws (23), eight washers (3), four lockwashers (5), and four nuts (6).

NOTE

Ensure holes in antenna base are aligned with weldnut holes in mounting bracket.

28-11. Install antenna (24) and gasket (17) on antenna offset mount (18) and secure with four screws (14), lockwashers (15), and washers (16).

NOTE

Prior to securing antenna ground lead, enlarge hole on offset mount with 9/32-in. drill bit to allow 1/4-in. screw to fit.

28-12. Secure antenna ground lead (20) to antenna offset mount (18) with screw (22), two lockwashers (21), and nut (19).

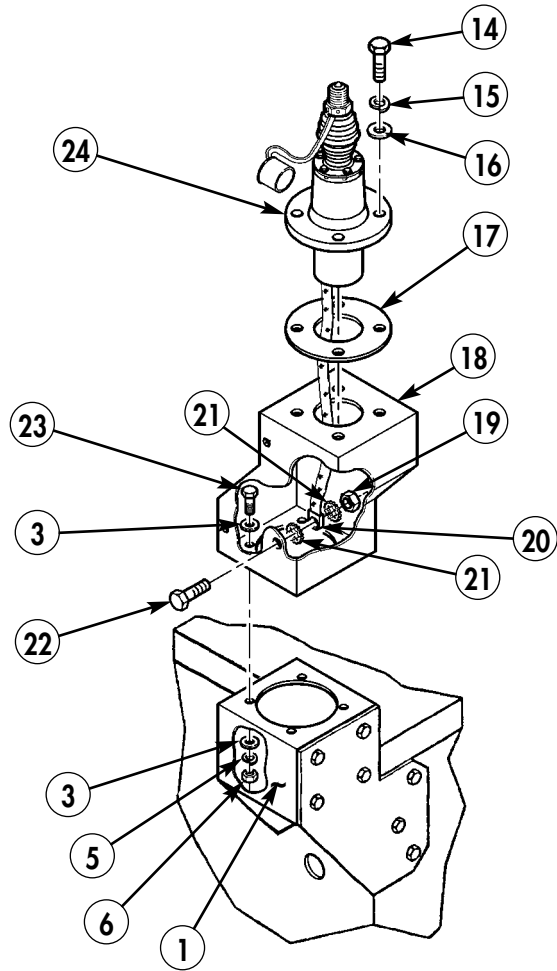

- | | |
|--------------------------------------|--------------------------------------|
| 3. WASHER – MS15795-814 – QTY. 8 | 18. OFFSET MOUNT – A3046219 – QTY. 1 |
| 5. LOCKWASHER – MS35338-141 – QTY. 4 | 19. NUT – MS35650-302 – QTY. 1 |
| 6. NUT – MS35690-610 – QTY. 4 | 21. LOCKWASHER – MS45904-68 – QTY. 2 |
| 14. CAPSCREW – MS35307-365 – QTY. 4 | 22. SCREW – MS35207-263 – QTY. 1 |
| 15. LOCKWASHER – MS45904-72 – QTY. 4 | 23. SCREW – MS90725-62 – QTY. 4 |
| 16. WASHER – 2436163 – QTY. 8 | 24. ANTENNA – A3017899-2 – QTY. 1 |
| 17. GASKET – A3013655-1 – QTY. 1 | |

Figure 5-78.

- 28-13. Attach upper antenna element (25) to lower antenna element (27).
- 28-14. Attach antenna assembly to antenna base (24).
- 28-15. Attach fiber rope assembly (26) to upper antenna element (25).
- 28-16. Secure lower antenna element (27) to antenna base (24) with lockwire (28).

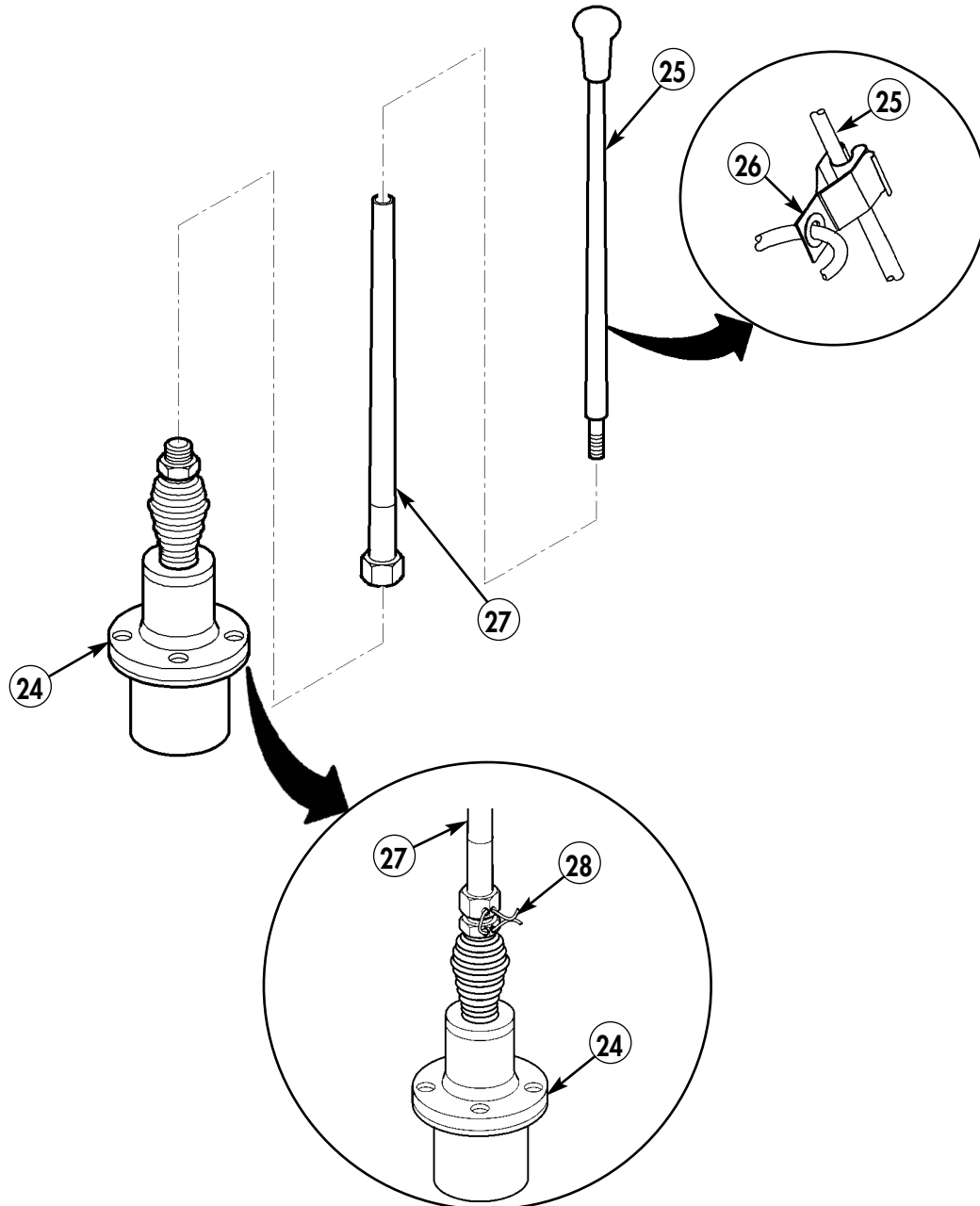

- 25. UPPER ANTENNA ELEMENT – A3017901-2 – QTY. 1
- 26. FIBER ROPE ASSEMBLY – A3167672-1 – QTY. 1
- 27. LOWER ANTENNA ELEMENT – A3018230-1 – QTY. 1
- 28. LOCKWIRE – MS20995C32 – QTY. A/R

Figure 5-79.

Section XXIX. VEHICLE GROUND INSTALLATION

29-1. Locate, mark, and drill one 0.343-in. diameter hole (2) in rear wall (1).

29-2. Install one screw (3), two lockwashers (4), one nut (5), two washers (6), and one wingnut (7) in rear wall (1).

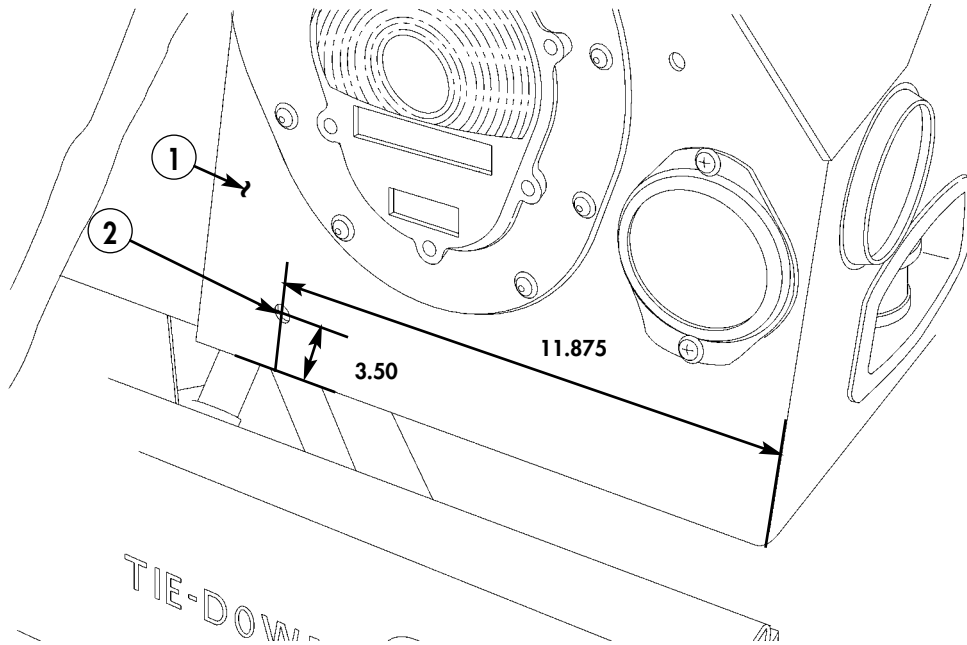
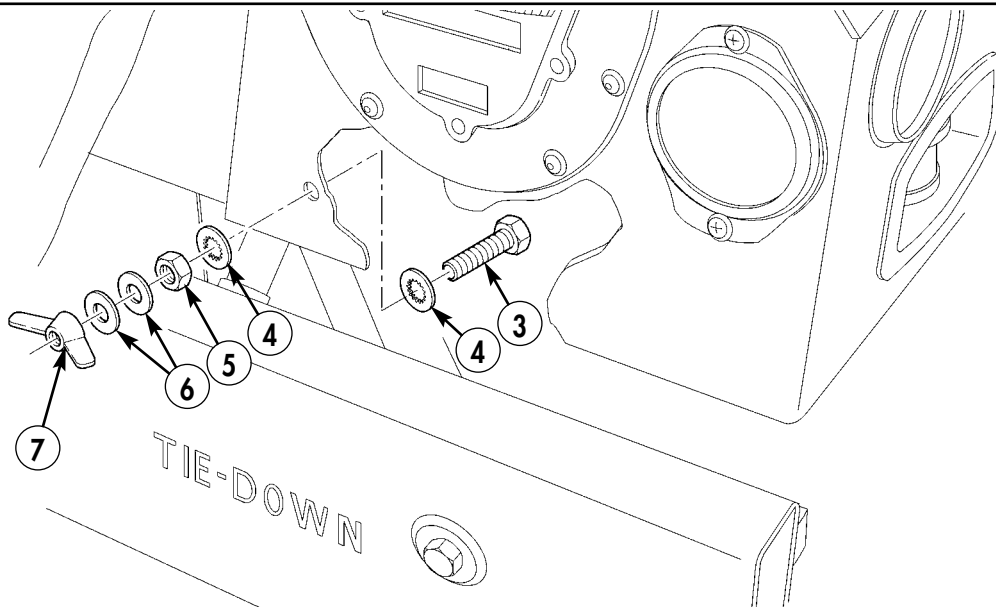

Figure 5-80.



- 3. SCREW - B1821BH038C150N - QTY. 1
- 4. LOCKWASHER - MS35333-76 - QTY. 2
- 5. NUT - MS51967-9 - QTY. 1
- 6. WASHER - 2436163 - QTY. 2
- 7. WINGNUT - MS35425-75 - QTY. 1

Figure 5-81.

Section XXX. QEAM: ANTENNAS AND BRACKETS INSTALLATION

30-1. Install four clamp subassemblies (5) on QEAM rack (4) with four screws (1), washers (2), and lockwashers (3).

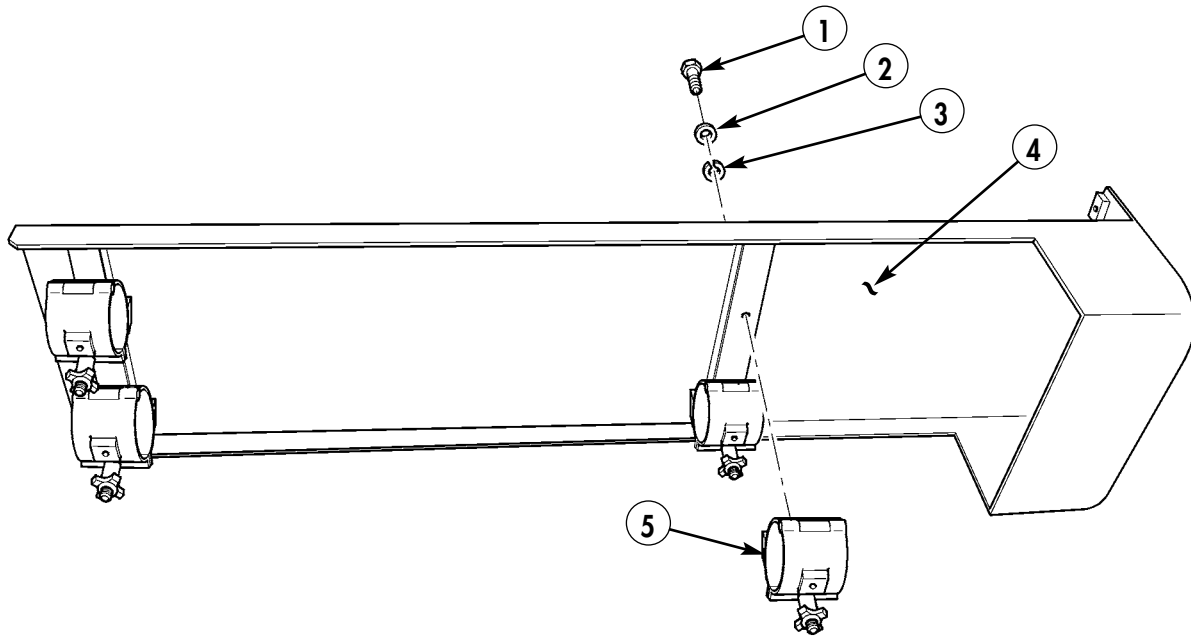

- 1. SCREW – 8599267-531 – QTY. 4
- 2. WASHER – MS27183-14 – QTY. 4
- 3. LOCKWASHER – MS35338-46 – QTY. 4
- 4. QEAM RACK – A3265715 – QTY. 1
- 5. CLAMP SUBASSEMBLY – A3209994 – QTY. 4

Figure 5-82.

- 30-2. Using QEAM rack (4) as template, locate, mark, and drill four 0.344-in. diameter holes (9) in roof of vehicle (14).
- 30-3. Mark location for four QEAM spacers (8) and apply RTV sealant to marked areas (10).

NOTE

Allow RTV to cure for 30 minutes.

- 30-4. Press four spacers (8) onto roof of vehicle (14).
- 30-5. Position QEAM rack (4) over holes in four spacers (8).
- 30-6. Apply RTV to four bolt holes (9) and insert four bolts (6) and washers (7) into QEAM carrier.
- 30-7. Apply RTV to one side of four washers (11). Press washers (11) in place.
- 30-8. Install lockwasher (12) and nut (13).

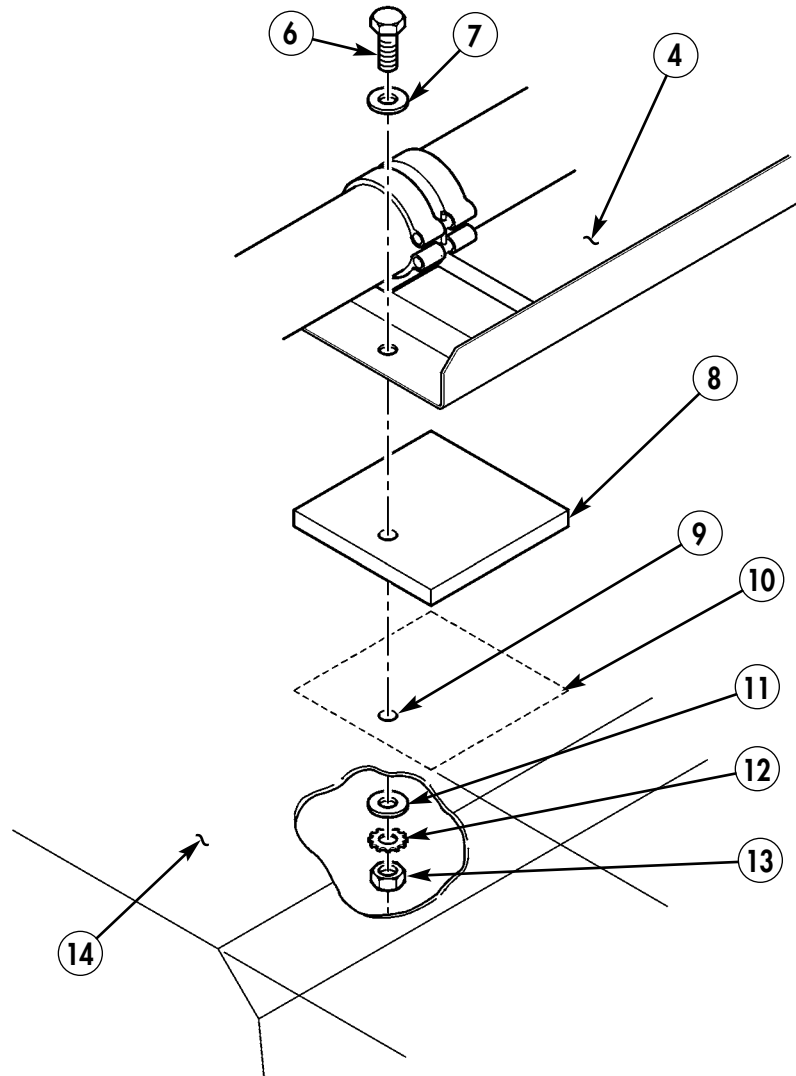

- 6. SCREW – B1821BH031C300N – QTY. 4
- 7. WASHER – 120393 – QTY. 4
- 8. QEAM SPACER (PART OF A3265715) – QTY. 4
- 11. WASHER – 120393 – QTY. 4
- 12. LOCKWASHER – MS45904-72 – QTY. 4
- 13. NUT – MS51967-6 – QTY. 4

Figure 5-83.

NOTE

Use folding step as a template to correctly space holes.

30-9. Locate, mark, and drill two 0.328-in. diameter holes (16) in body of vehicle (15).

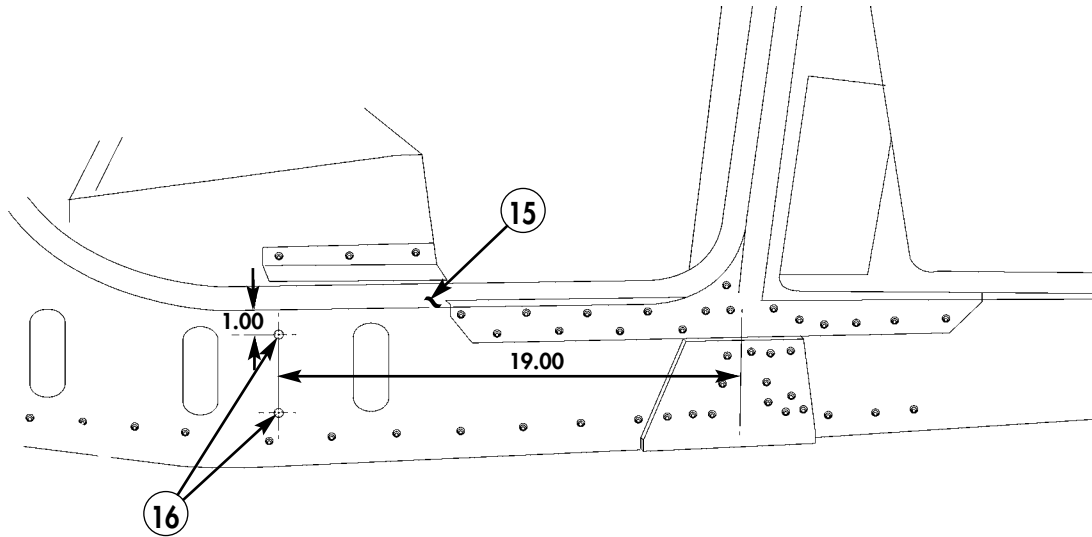

Figure 5-84.

30-10. Locate, mark, and drill two 0.328-in. diameter holes (17) in body of vehicle (15).

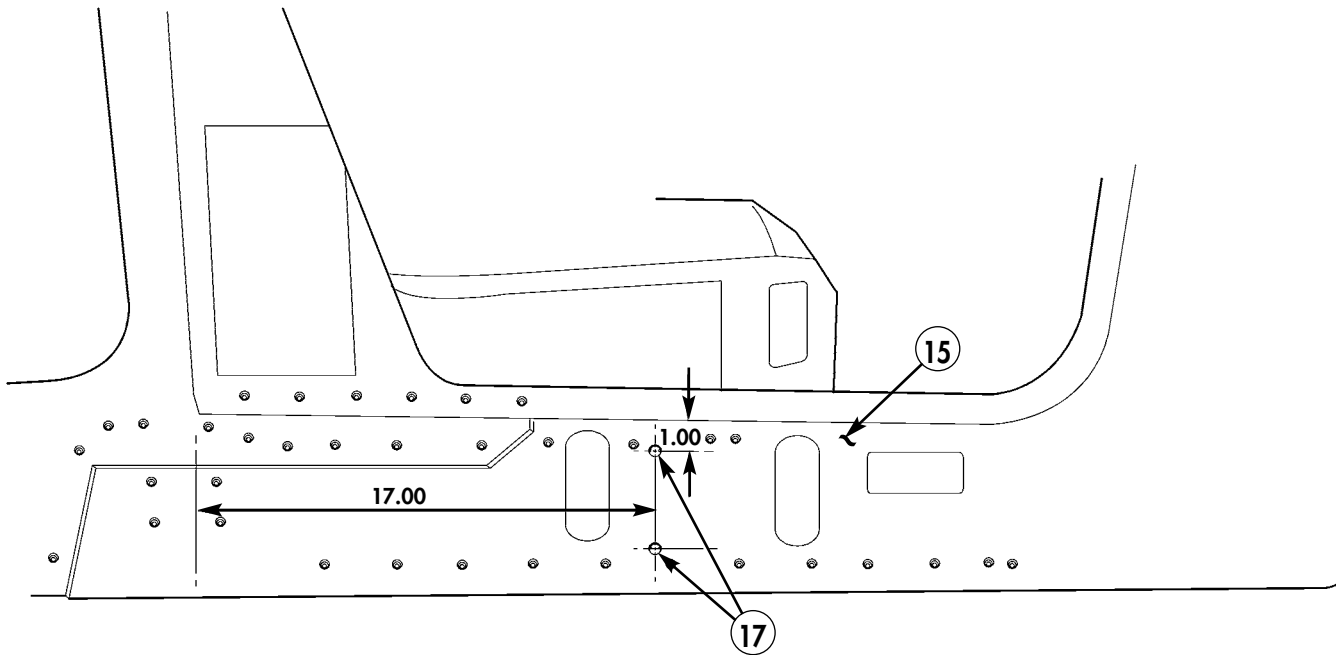
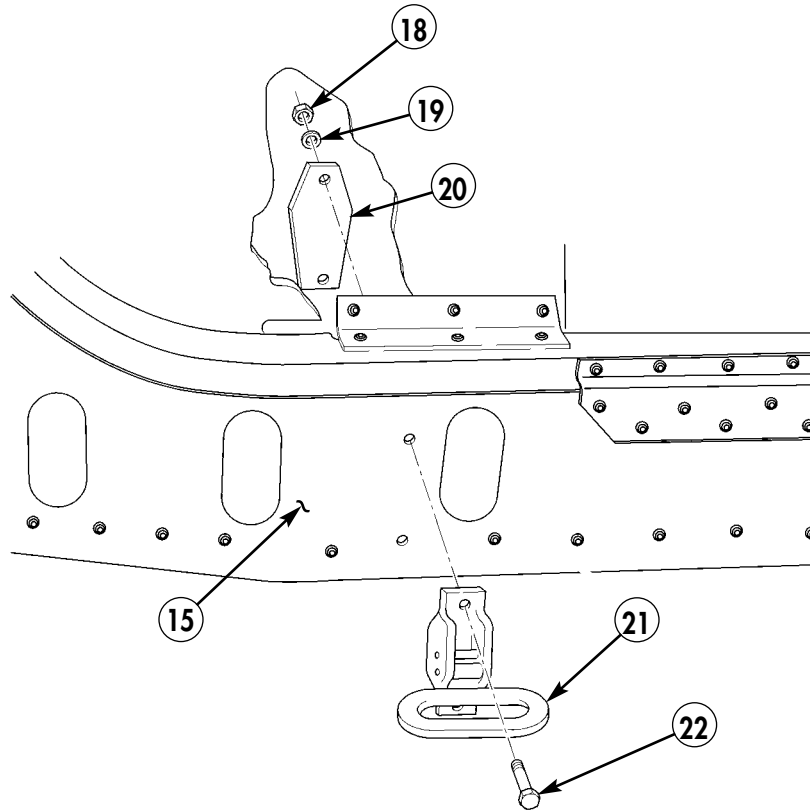

Figure 5-85.

NOTE

Rear folding step installation is shown. Front folding step is mounted the same way.

- 30-11.** Install two folding steps (21) on body of vehicle (15) with four screws (22), two backing plates (20), four washers (19), and four locknuts (18).



18. LOCKNUT - MS17829-5C - QTY. 4
 19. WASHER - MS51412-25 - QTY. 4
 20. BACKING PLATE - P/O A3265715 - QTY. 2
 21. FOLDING STEP - P/O A3265715 - QTY. 2
 22. SCREW - B1821BH031C125N - QTY. 4

Figure 5-86.

Section XXXI. SINGGARS ANTENNA CABLE INSTALLATION

NOTE

Loosen left- and right-side tunnel insulation.
(Refer to TM 9-2320-280-20.)

- 31-1. Route antenna cable (1) and power cable (2) from left side of mounting base (11), down through center access hole (4), under integrated rack (5), and under right-side tunnel insulation (7) towards rear of vehicle.
- 31-2. Route antenna cable (10) from mounting base (11) to MT-6353/VRC mounting base (9).
- 31-3. Route power amp cable (3) from MT-6353/VRC mounting base (9) up through center access hole (4) and connect power amp cable (3) to W1J1 cable (3.1).
- 31-4. Route control cable (8) from MT-6353/VRC mounting base (9) up through center access hole (4) to mounting base (11).
- 31-5. Route antenna cable (6) from front of MT-6353/VRC mounting base (9), under integrated rack (5), and under right-side tunnel insulation (7) towards rear of vehicle.

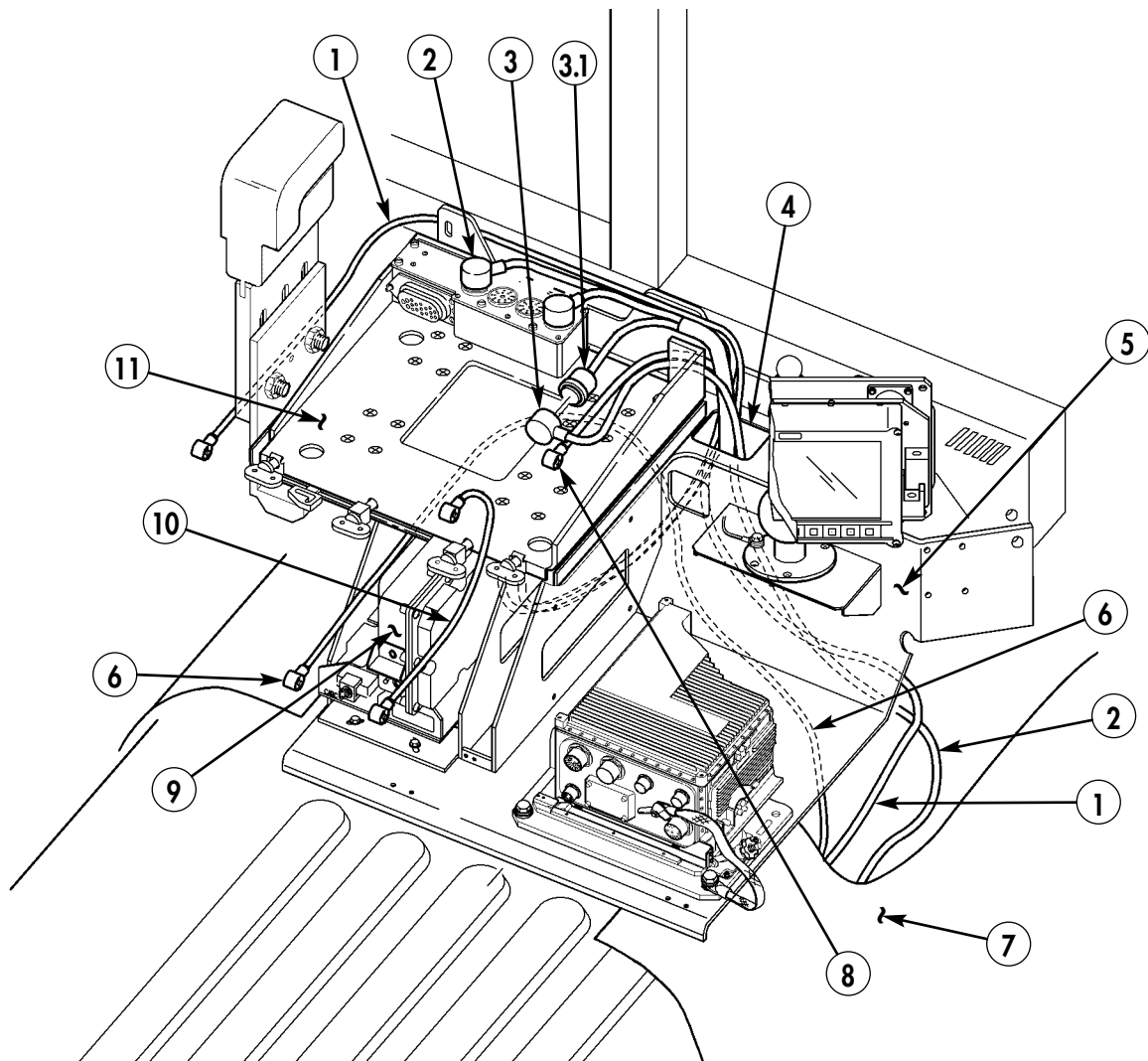

- 1. ANTENNA CABLE – A3014031-8 – QTY. 1
- 2. SINGGARS POWER CABLE – A3014039-2 – QTY. 1
- 6. ANTENNA CABLE – A3014031-17 – QTY. 1
- 10. ANTENNA CABLE – A3014032-3 – QTY. 1

Figure 5-87.

- 31-6.** Route two antenna cables (1) and (6) along right-rear seat/utility area with four self-tapping screws (13) and loop clamps (12).
- 31-7.** Route two antenna cables (1) and (6) through right wheelhouse/utility area with existing grommet, retainer, screws, and nut and lockwasher assemblies. (Refer to TM 9-2320-280-20.)

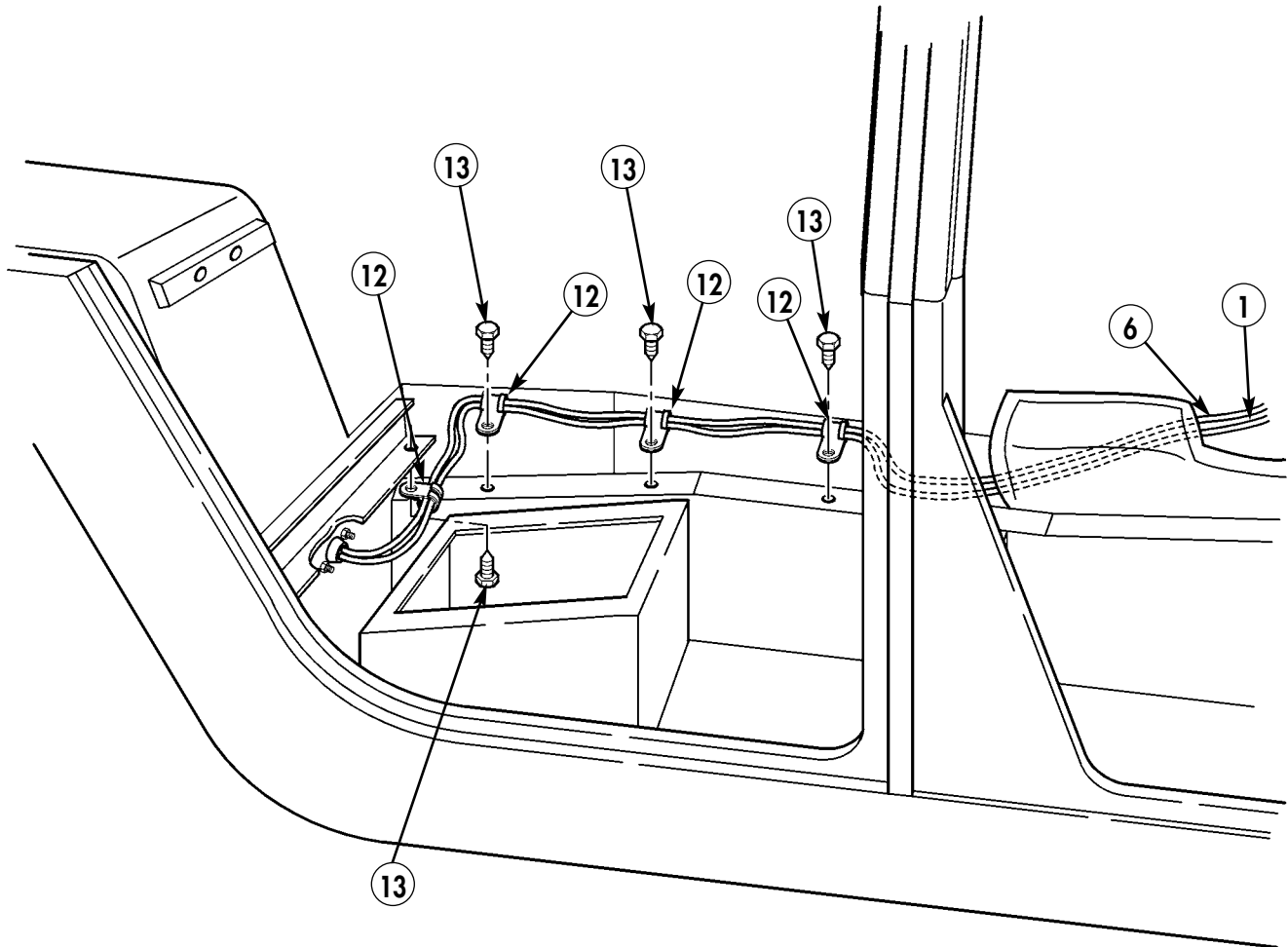

- 12. LOOP CLAMP – MS21333-69 – QTY. 4**
- 13. SELF-TAPPING SCREW – 9421073 – QTY. 4**

Figure 5-88.

- 31-8. Route two antenna cables (1) and (6) along front wheelwell seam (16) and along front (14), intermediate (35), and rear (33) cargo bed supports. Secure with two self-tapping screws (13), loop clamps (12), screw (17), loop clamp (12), nut (15), and existing self-tapping screw (18) and loop clamp (33).
- 31-9. Route antenna cable (1) along existing taillight wiring harness (44) with two existing loop clamps (27) and (26), self-tapping screws (18), and lockwashers (25).
- 31-10. Route antenna cable (1) to antenna base (32) with existing loop clamp (19), nut (23), lockwasher (22), washer (21), and screw (20).
- 31-11. Attach antenna cable (1) to antenna base (32).
- 31-12. Coil excess antenna cable (1) and secure to inside of taillight closeout cover with tiedown strap (24).
- 31-13. Attach cover plate (31) to offset antenna mount (28) with four screws (29) and four washers (30).

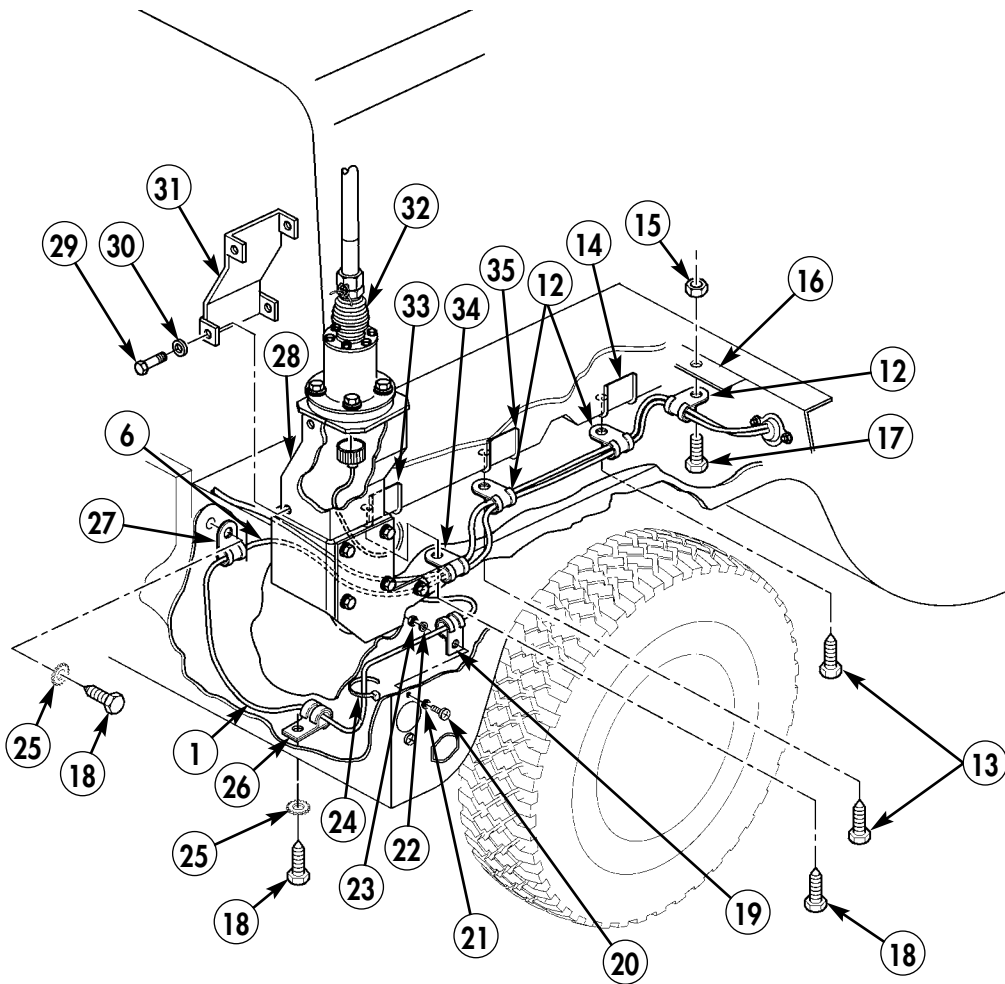

- 12. LOOP CLAMP – MS21333-69 – QTY. 3
- 13. SELF-TAPPING SCREW – 9421073 – QTY. 2
- 15. NUT – MS35650-302 – QTY. 1
- 17. SCREW – MS35224-65 – QTY. 1
- 24. TIE STRAP – MS3367-1-0 – QTY. A/R
- 29. SCREW – MS90725-30 – QTY. 4
- 30. WASHER – MS27183-12 – QTY. 4

Figure 5-89.

- 31-14. Route antenna cable (6) along existing taillight wiring harness (44) on rear cargo bed support (33) and secure with four existing loop clamps (45), (46), (47), (48), and existing self-tapping screws (40).
- 31-15. Route antenna cable (6) along existing taillight wiring harness (44) on left-side frame rail with three existing loop clamps (43), (42), and (48), and existing self-tapping screws (40) and lockwashers (41).
- 31-16. Route antenna cable (6) to antenna base (36) with existing loop clamp (37), screw (53), lockwasher (38), and nut (39).
- 31-17. Attach antenna cable (6) to antenna base (36).
- 31-18. Coil excess antenna cable (6) and secure to inside of taillight closeout cover with tiedown strap (49).
- 31-19. Attach cover plate (50) to offset antenna mount (54) with four screws (51) and washers (52).

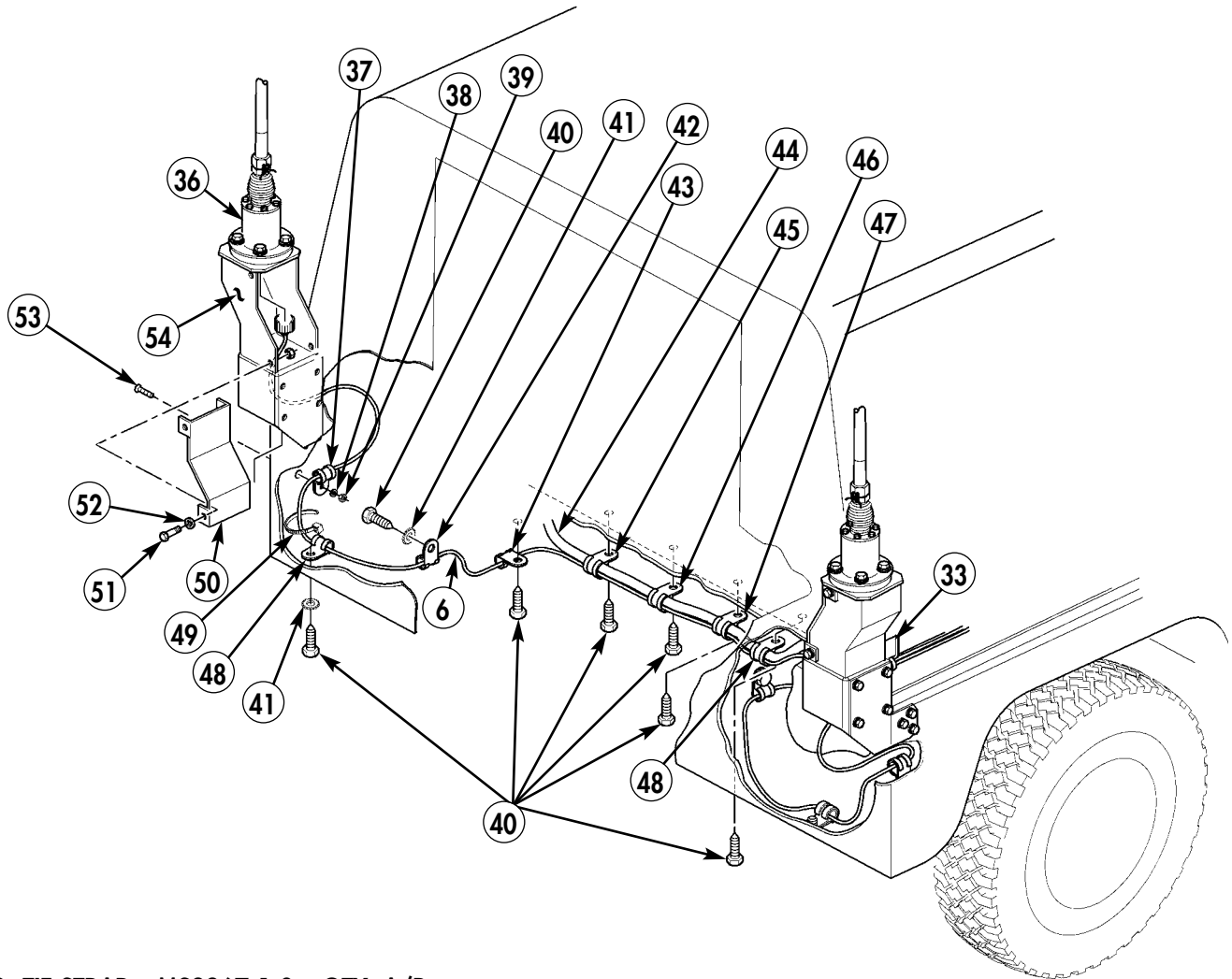

- 49. TIE STRAP – MS3367-1-0 – QTY. A/R
- 51. SCREW – MS90725-30 – QTY. 4
- 52. WASHER – MS27183-12 – QTY. 4

Figure 5-90.

Section XXXII. PLGR POWER CABLE INSTALLATION

32-1. Route INC-EPUU cable (1) from mounting base (5), through access hole (2), under right-side tunnel insulation (4), to rear battery box.

32-2. Route PLGR power cable (3) under right-side tunnel insulation (4) to rear battery box.

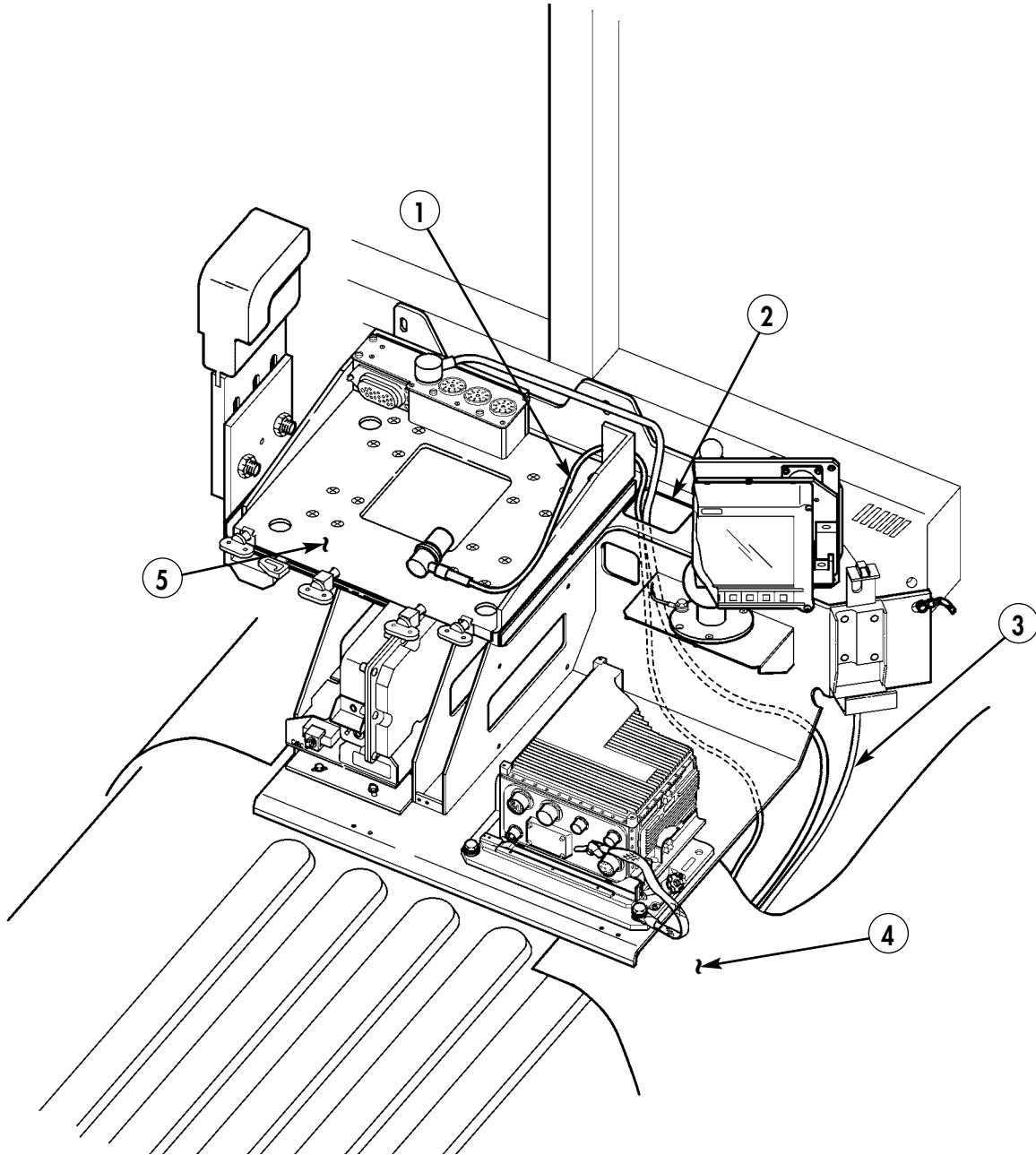

- 1. INC-EPUU CABLE – A3279383-3 – QTY. 1
- 3. PLGR-POWER CABLE – 9728558-10 – QTY. 4

Figure 5-91.

Section XXXIII. LEFT-SIDE EPLRS ANTENNA CABLE INSTALLATION

- 33-1.** Connect EPLRS antenna cable (2) to EPLRS antenna (1).
- 33-2.** Route EPLRS antenna cable (2) through hole in bracket (3) and fiberglass body (4). Secure with clamp (6) and self-tapping screw (5).

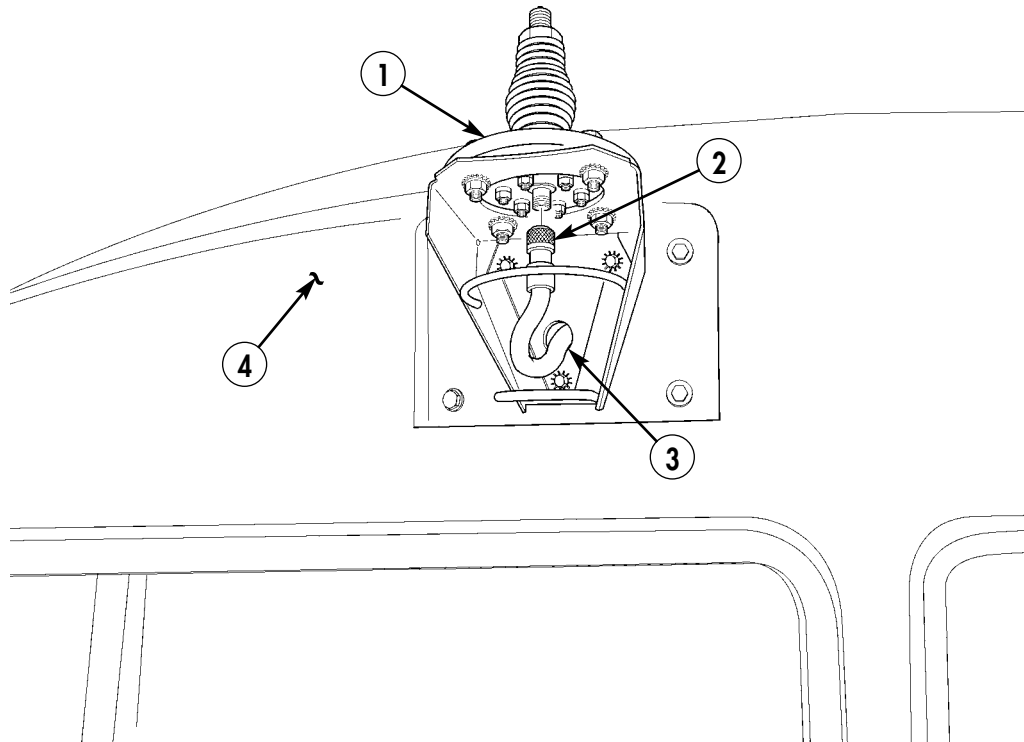

2. EPLRS ANTENNA CABLE – SM-C-911480 – QTY. 1

Figure 5-92.

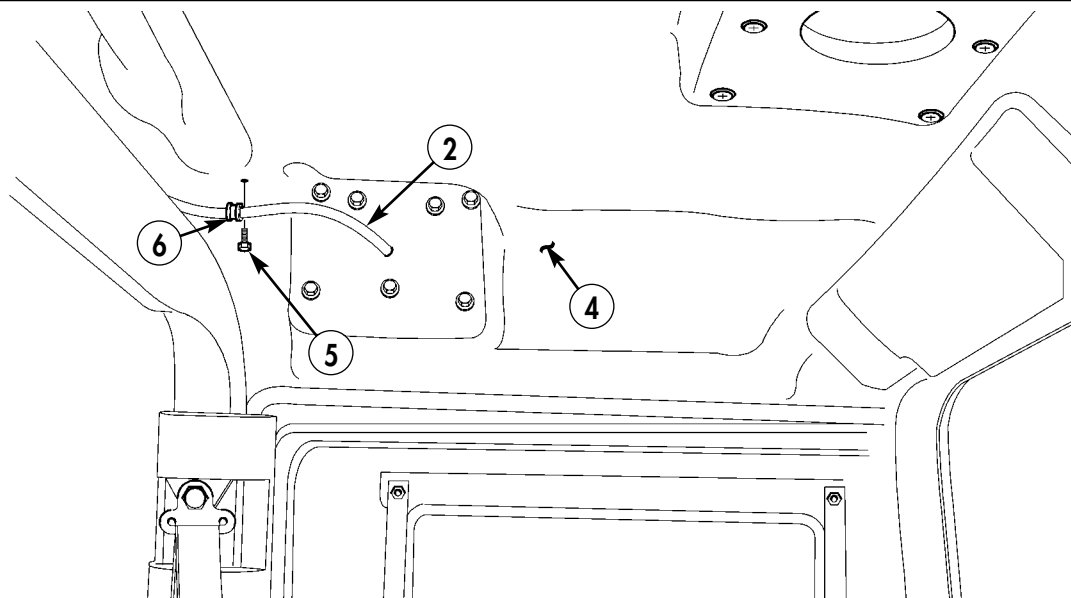

5. SELF-TAPPING SCREW – 9421073 – QTY. 1

6. LOOP CLAMP – MS21333-71 – QTY. 1

Figure 5-93.

33-3. Route EPLRS antenna cable (2) to C-pillar (7) and secure with clamp (6) and self-tapping screw (5).

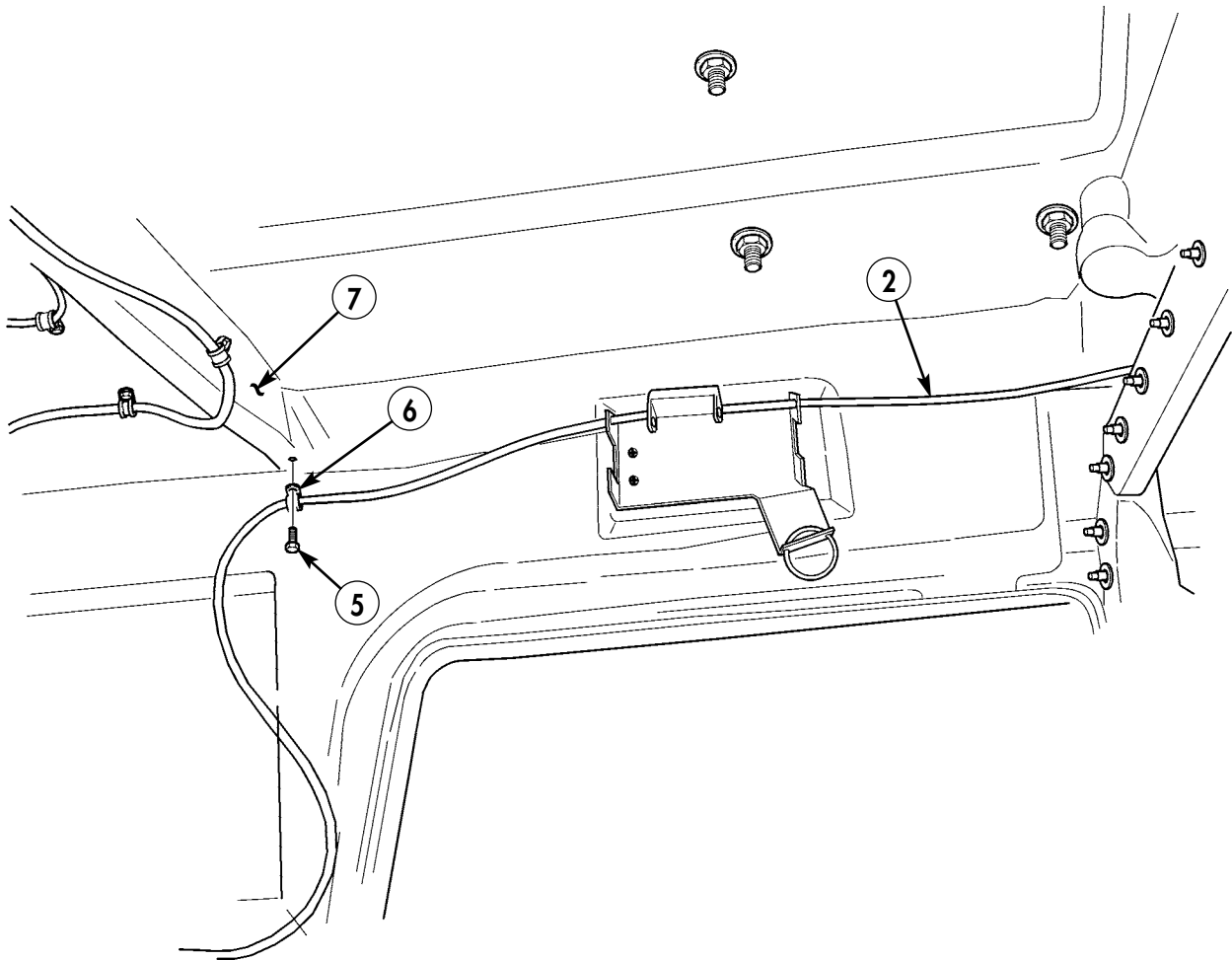

- 5. SELF-TAPPING SCREW - 9421073 - QTY. 1
- 6. LOOP CLAMP - MS21333-71 - QTY. 1

Figure 5-94.

- 33-4. Route cable (2) down cargo box (10) to rear wheelhouse (11) and secure with clamp (6) and self-tapping screw (5).
- 33-5. Locate, mark, and drill four 0.281-in. diameter holes (12) in rear wheelhouse (11).

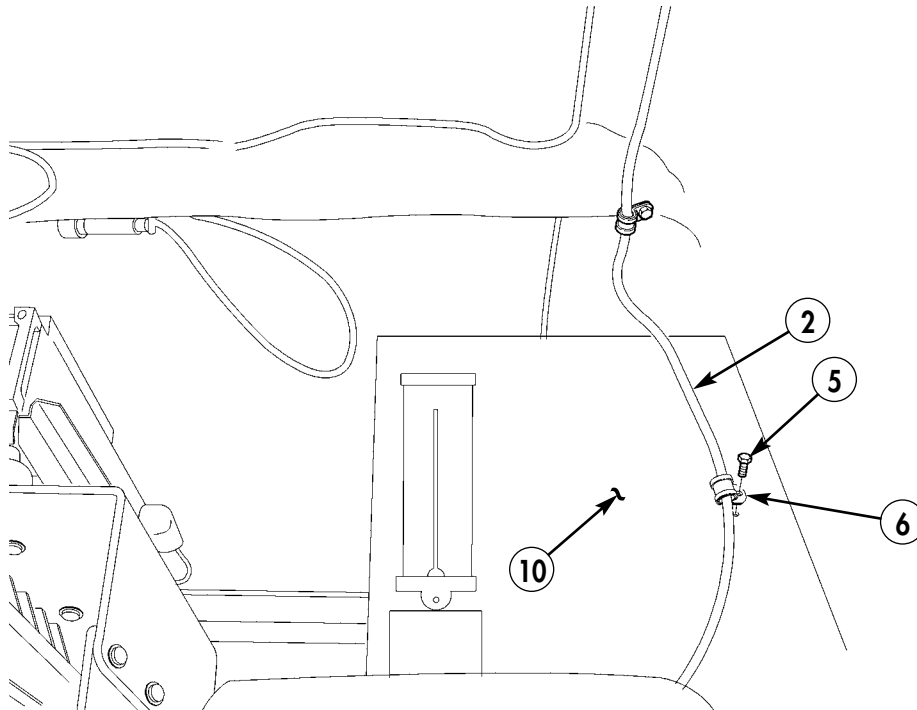

- 5. SELF-TAPPING SCREW - 9421073 - QTY. 1
- 6. LOOP CLAMP - MS21333-71 - QTY. 1

Figure 5-95.

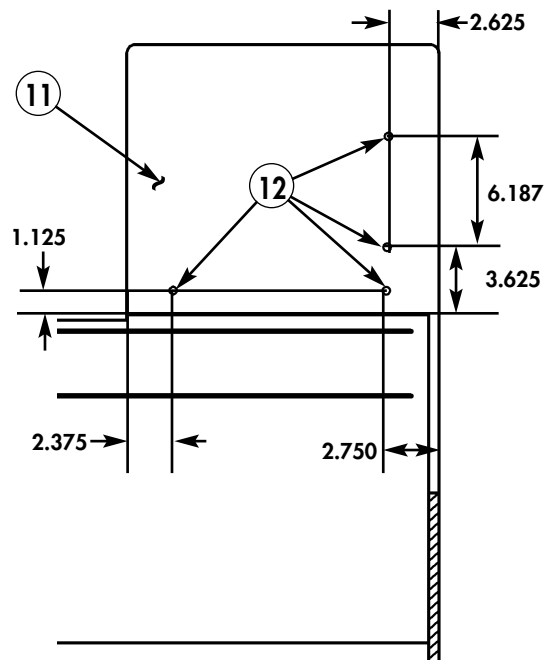
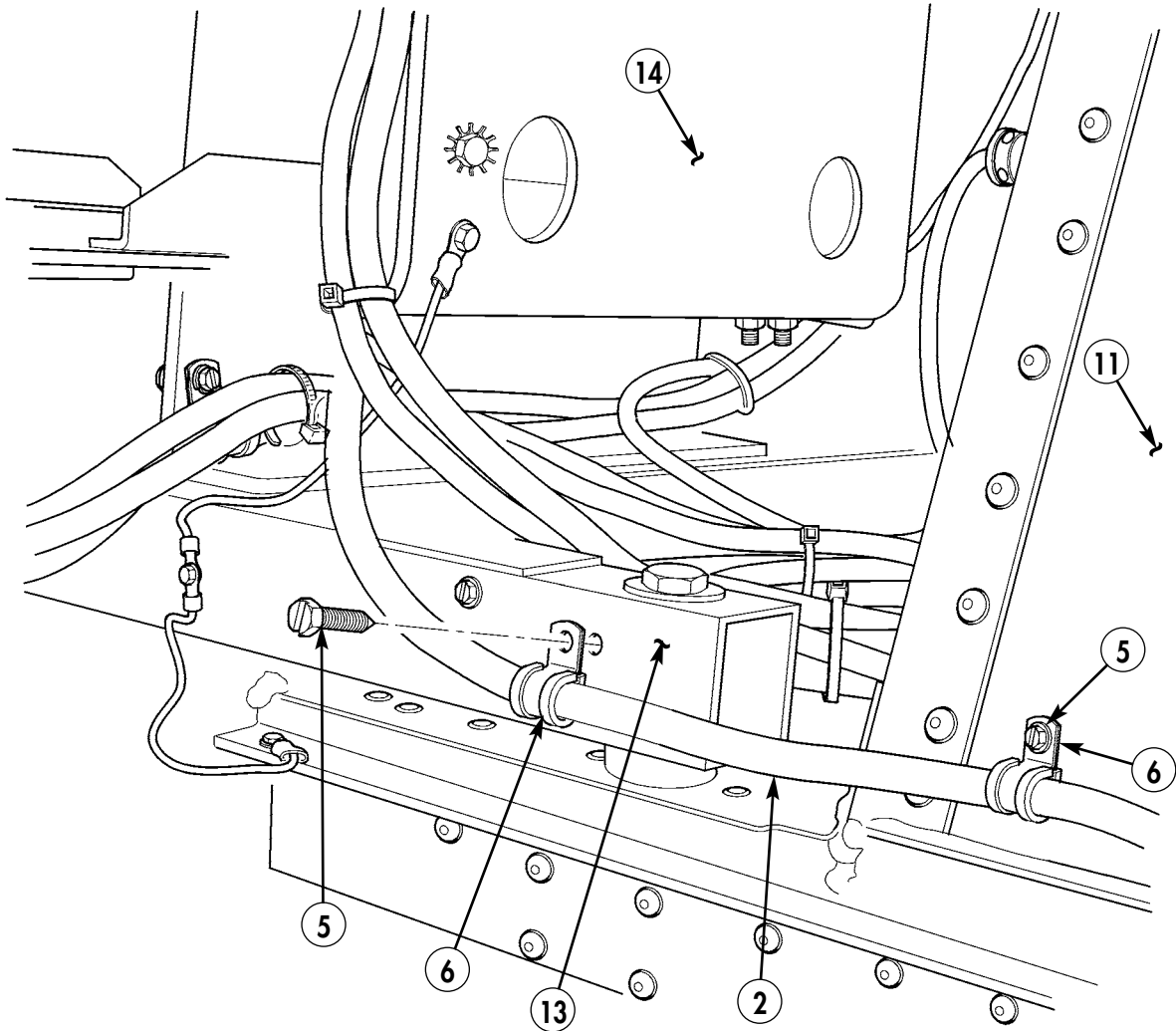

Figure 5-96.

- 33-6. Route cable (2) along rear wheelhouse (11) to multi-net frame (13).
- 33-7. Secure cable (2) to rear wheelhouse (11) using four clamps (6) and screws (5).
- 33-8. Secure cable (2) to multi-net frame (13) using clamp (6) and screw (5).
- 33-9. Route cable (2) to vicinity of upper EPLRS mount (14).



- 5. SELF-TAPPING SCREW - 9421073 - QTY. 5
- 6. LOOP CLAMP - MS21333-71 - QTY. 5

Figure 5-97.

Section XXXIV. RIGHT-SIDE EPLRS ANTENNA CABLE INSTALLATION

- 34-1.** Connect EPLRS antenna cable (5) to EPLRS antenna (2).
- 34-2.** Route EPLRS antenna cable (5) through hole (4) in bracket (1) and fiberglass body (3).
- 34-3.** Route EPLRS antenna cable (5) to C-pillar (8) and secure with two clamps (6) and self-tapping screws (7).

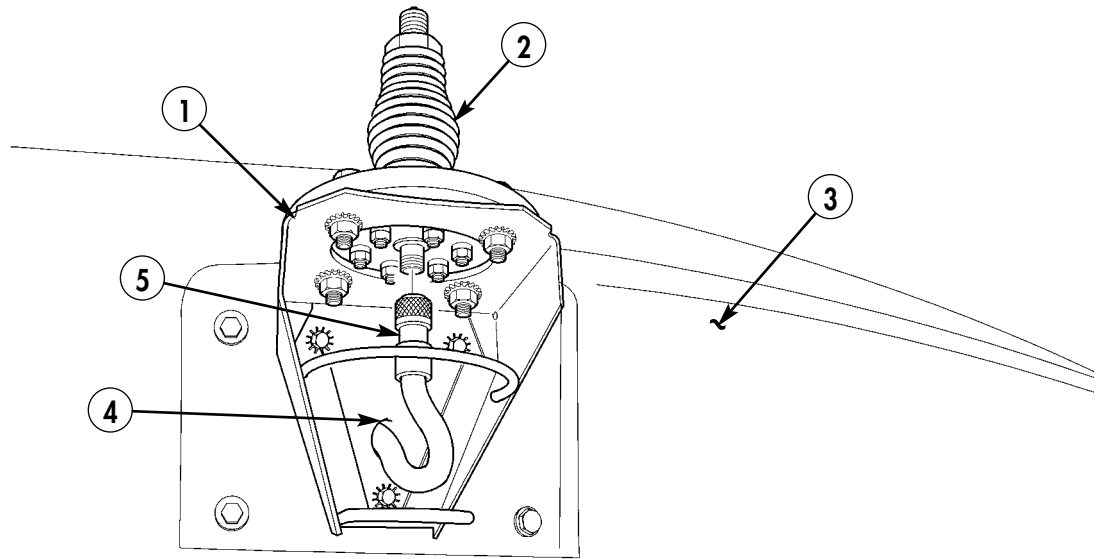

5. EPLRS ANTENNA CABLE – SM-C-911480 – QTY. 1

Figure 5-98.

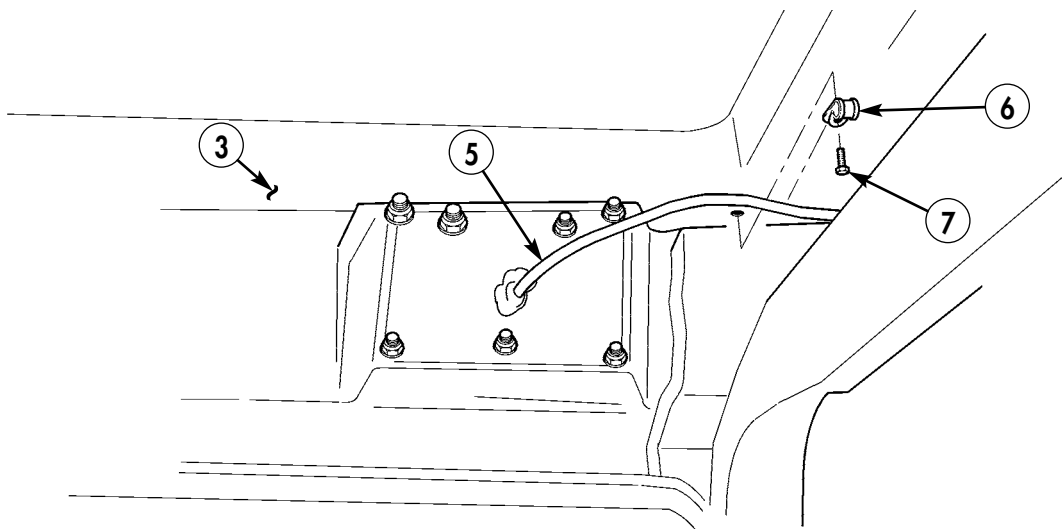

- 6. LOOP CLAMP – MS21333-71 – QTY. 1**
- 7. SELF-TAPPING SCREW – 9421073 – QTY. 1**

Figure 5-99.

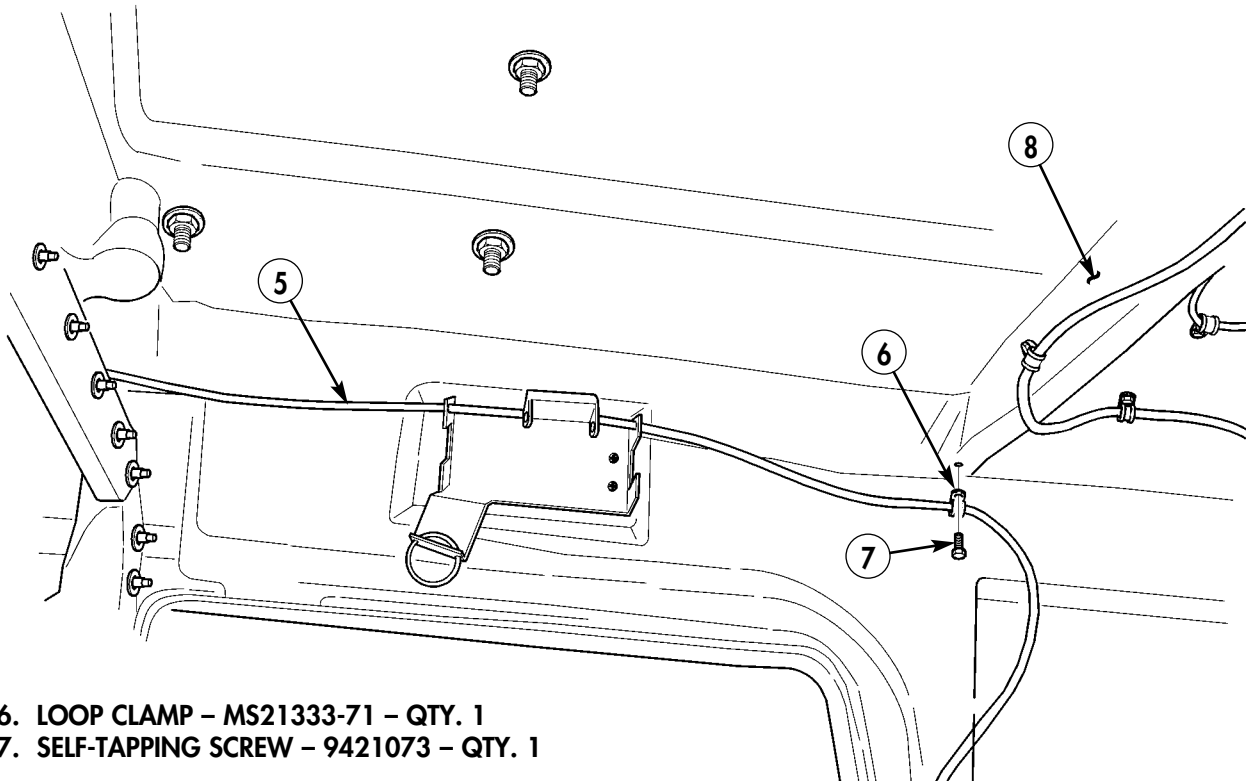

- 6. LOOP CLAMP - MS21333-71 - QTY. 1
- 7. SELF-TAPPING SCREW - 9421073 - QTY. 1

Figure 5-100.

- 34-4. Route EPLRS antenna cable (5) down C-pillar (8), to rear wheelhouse (9).
- 34-5. Route EPLRS antenna cable (5) along rear wheelhouse (9).
- 34-6. Locate, mark, and drill four 0.147-in. diameter holes (11) in wheelhouse (9).
- 34-7. Locate, mark, and drill two 0.281-in. diameter holes (10) in wheelhouse (9).

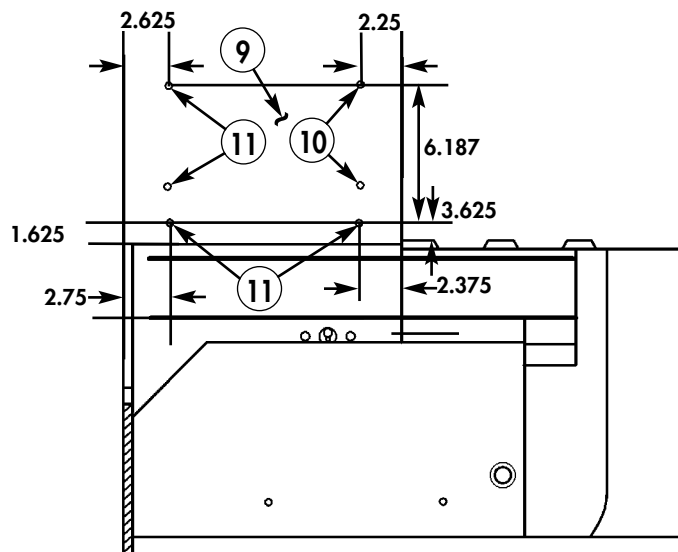
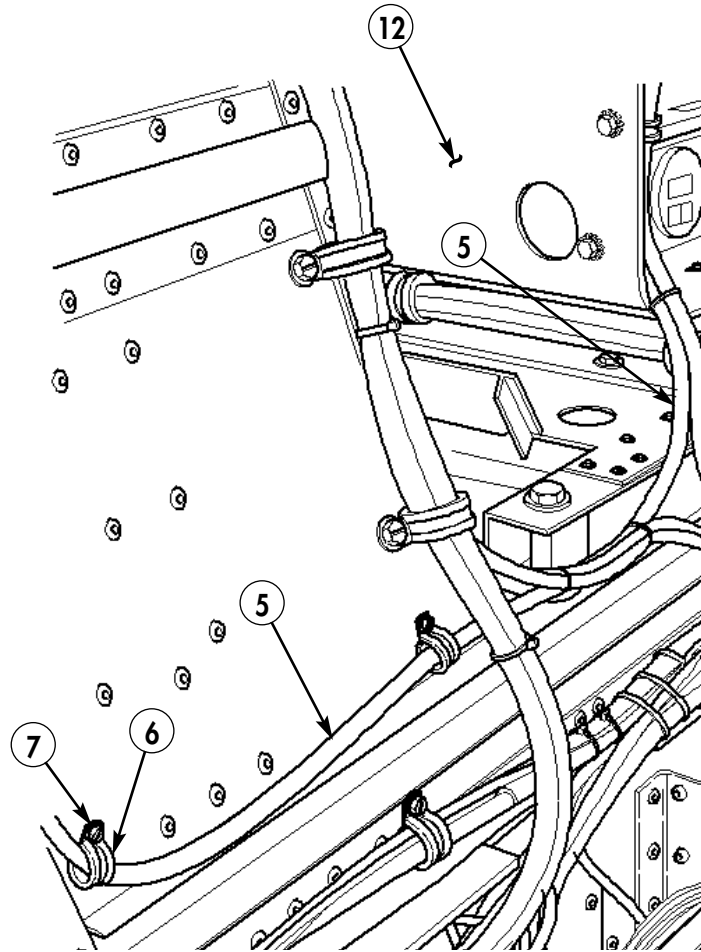

Figure 5-101.

- 34-8.** Route EPLRS antenna cable (5) along wheelhouse (9) to vicinity of lower EPLRS mount (12). Secure with four clamps (6) and self-tapping screws (7).



6. LOOP CLAMP - MS21333-71 - QTY. 4
 7. SELF-TAPPING SCREW - 9421073 - QTY. 4

Figure 5-102.

Section XXXV. COMPUTER STAND TUNNEL CABLE INSTALLATION

- 35-1.** Route Ethernet cable (3) from front cable carrier (5), along computer stand (4) lower shelf.
- 35-2.** Secure Ethernet cable (3), to computer stand (4) lower shelf with three clamps (1), and locknuts (2).
- 35-3.** Route DC-DC cable (7) from rear cable carrier (6), to DC-DC adapter (8).
- 35-4.** Route Parallel cable (10) and PCMCIA cable (9) from rear cable carrier (6), along computer stand (4) lower shelf.
- 35-5.** Secure Parallel cable (10) and PCMCIA cable (9), to computer stand (4) lower shelf with three clamps (11), and locknuts (2).
- 35-6.** Locate, mark, and drill four 0.147-in. diameter holes (13) in cargo floor (14).
- 35-7.** Route Ethernet cable (3), from computer stand (4) lower shelf along cargo floor (14) to KOK-13 support leg (18).
- 35-8.** Route Parallel cable (10) and PCMCIA cable (9), from computer stand (4) lower shelf along cargo floor (14) to KOK-13 support leg (18).
- 35-9.** Secure Ethernet cable (3), to cargo floor (14) with four clamps (1) and self-tapping screws (12).
- 35-10.** Secure Parallel cable (10) and PCMCIA cable (9), to cargo floor (14) with two clamps (11) and existing self-tapping screws (12).
- 35-11.** Secure Ethernet cable (3), to KOK-13 support leg (18) with clamp (1), screw (17), lockwasher (16), and locknut (15).
- 35-12.** Secure Parallel cable (10) and PCMCIA cable (9), to KOK-13 support leg (18) with clamp (11), existing screw (17), lockwasher (16), and locknut (15).

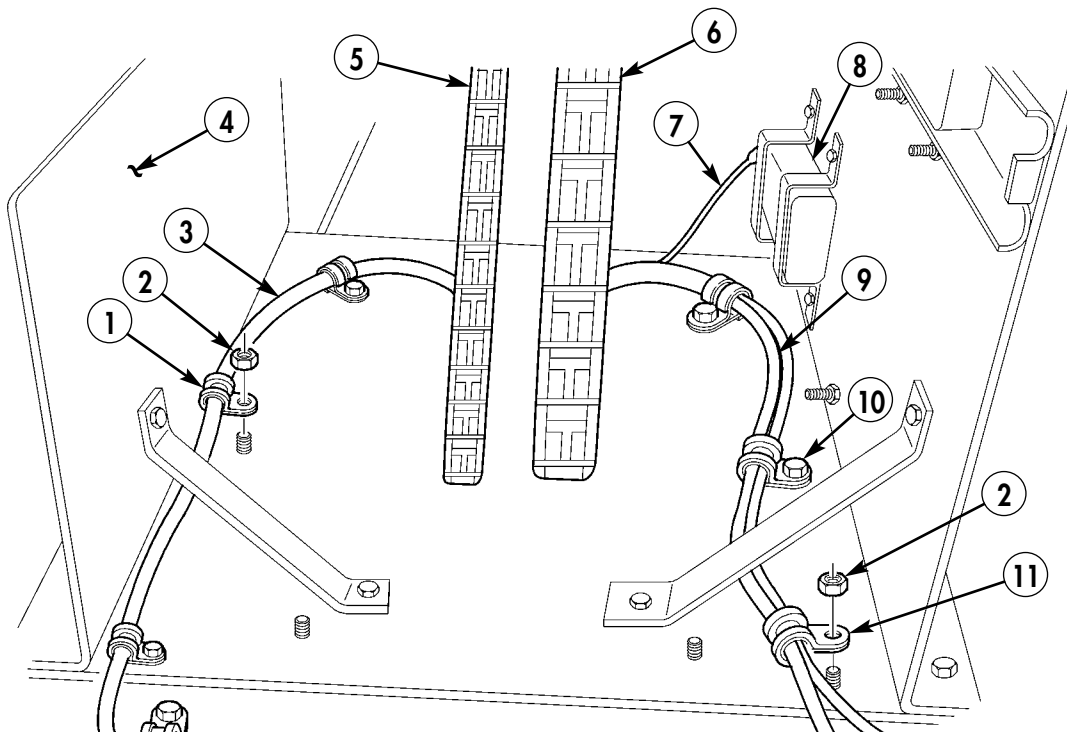

- 1. LOOP CLAMP – MS21333-69 – QTY. 3**
- 2. NUT – MS51967-5 – QTY. 6**
- 11. LOOP CLAMP – MS21333-75 – QTY. 3**

Figure 5-103.

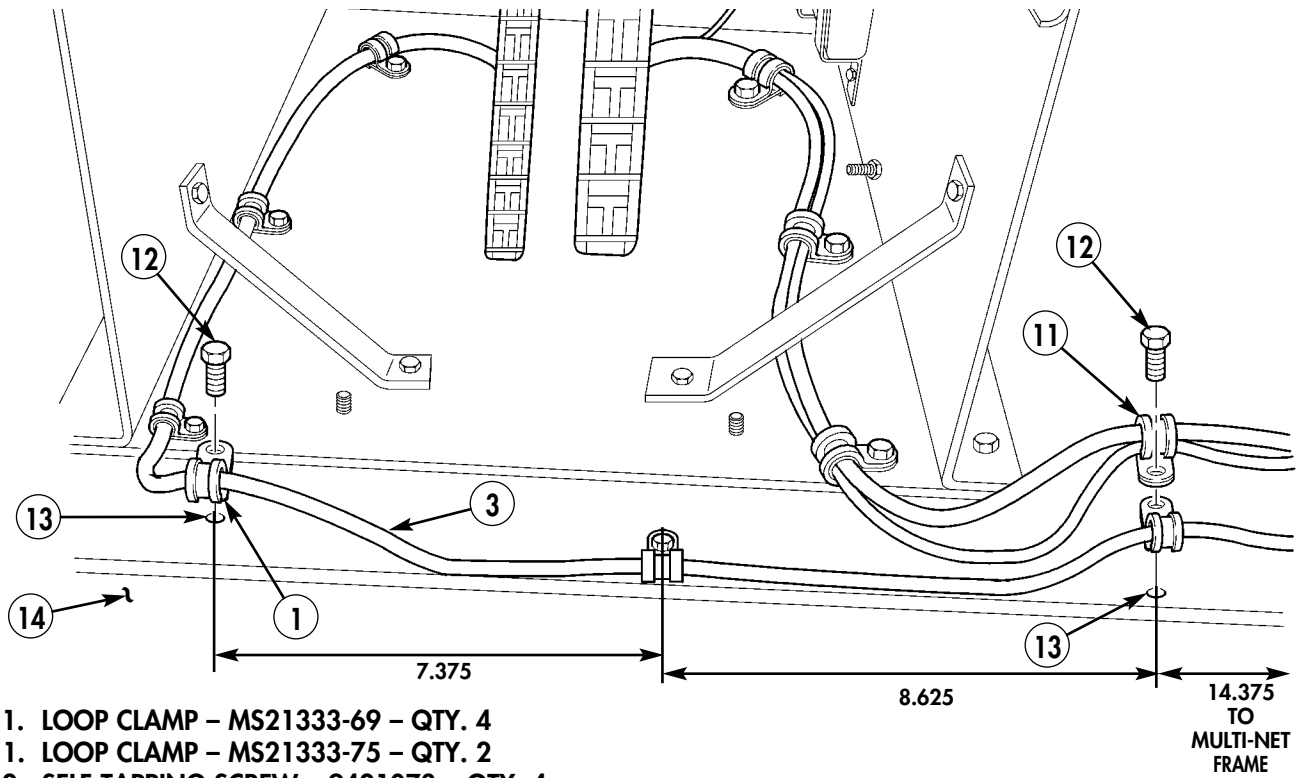

Figure 5-104.

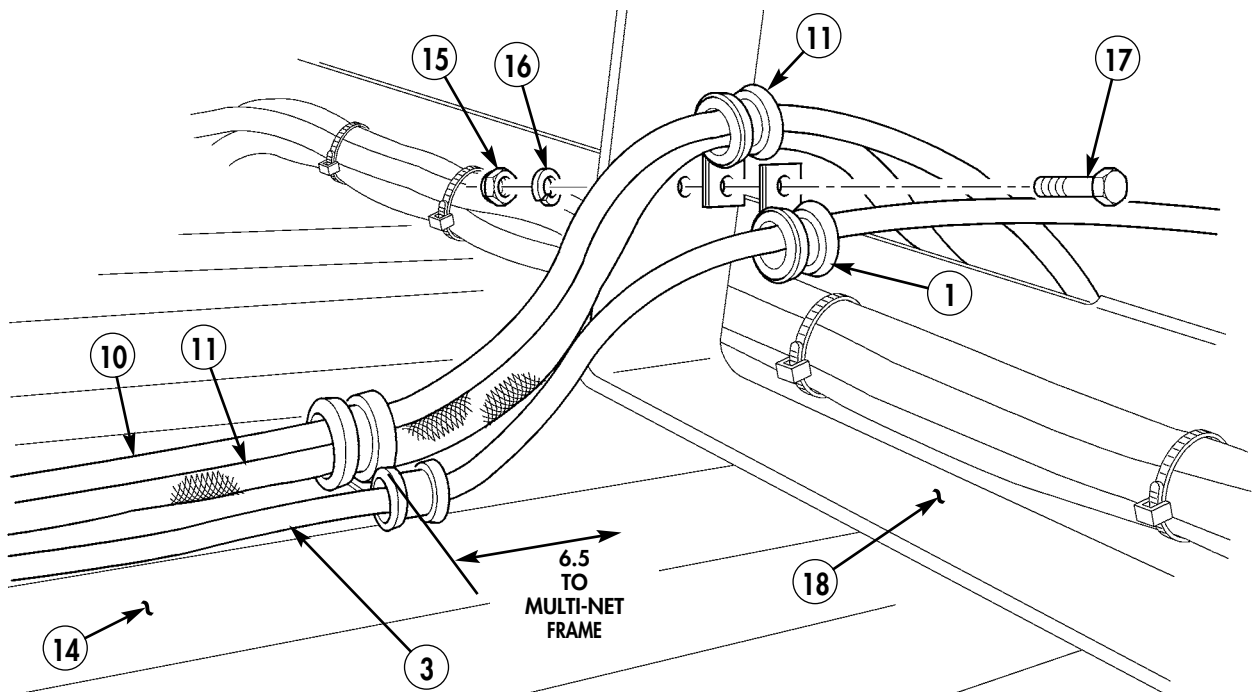
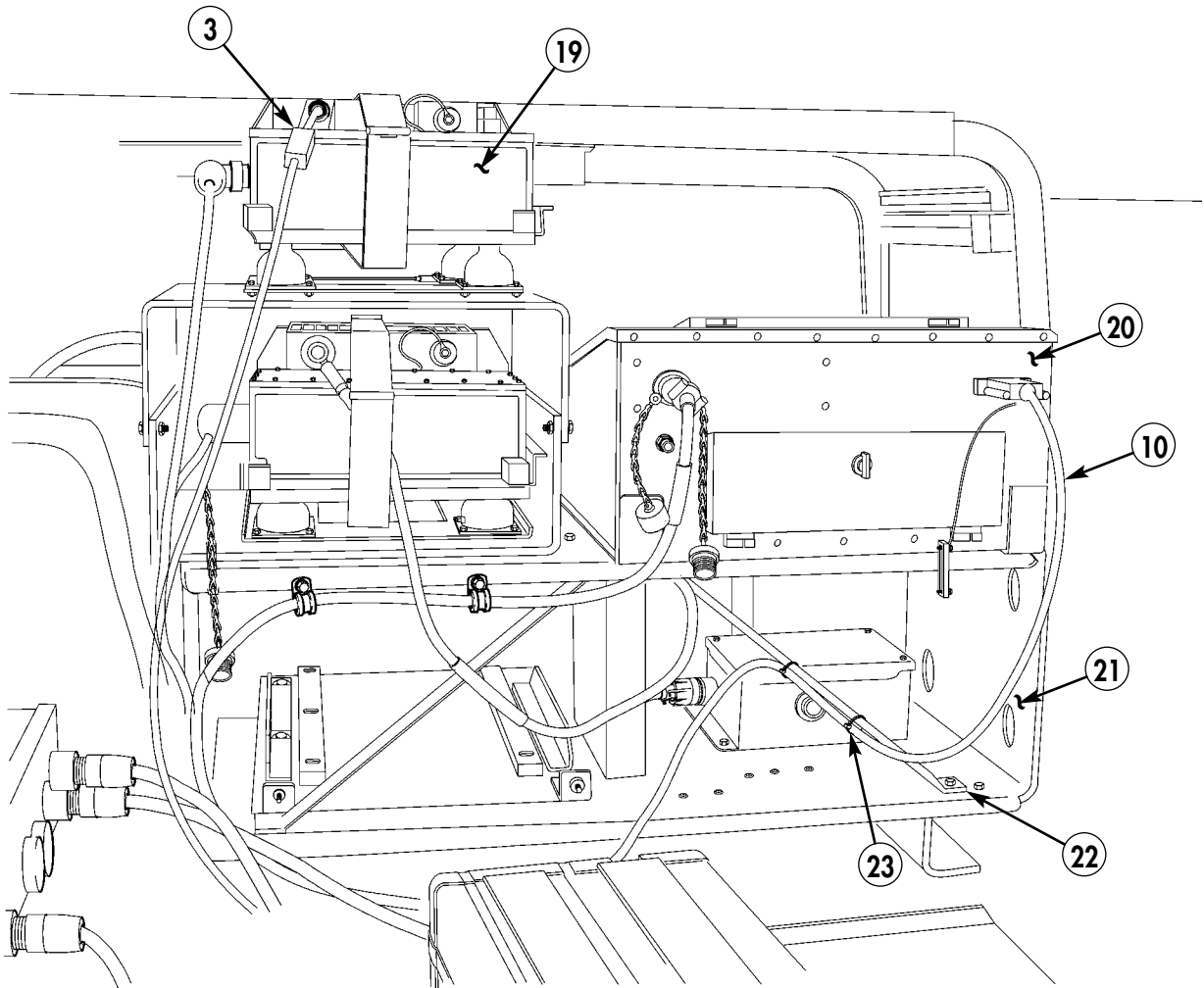

Figure 5-105.

- 35-13. Route Ethernet cable (3), from KOK-13 support leg (18) under multi-net rack (21) to upper EPLRS radio (19).
- 35-14. Route Parallel cable (10), from KOK-13 support leg (18) under multi-net rack (21) to printer (20).
- 35-15. Secure Parallel cable (10) to support brace (22) with two tiestraps (23).
- 35-16. Coil PCMCIA cable (9), under multi-net rack (21).



23. TIE STRAP – MS3367-1-0 – QTY. 2

Figure 5-106.

Section XXXVI. MASTER KILL SWITCH CABLE INSTALLATION

- 36-1.** Route master kill switch cables (1) and (4), from master kill switch (2) down computer stand (3) to tunnel (7).
- 36-2.** Route master kill switch cable (4) to rear battery box.
- 36-3.** Route master kill switch cable (1) through grommets hole (5) in cab enclosure panel (6) to vehicle battery (10).
- 36-4.** Secure master kill switch cable (1) to vehicle battery positive terminal (9) with existing nut (8).

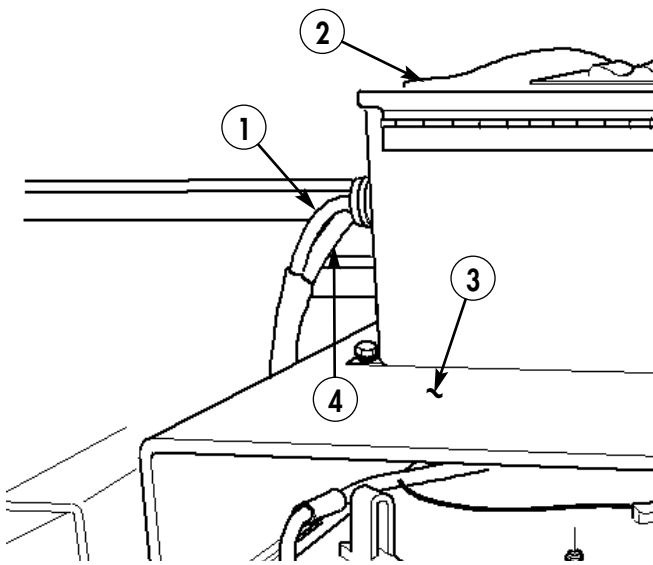

Figure 5-107.

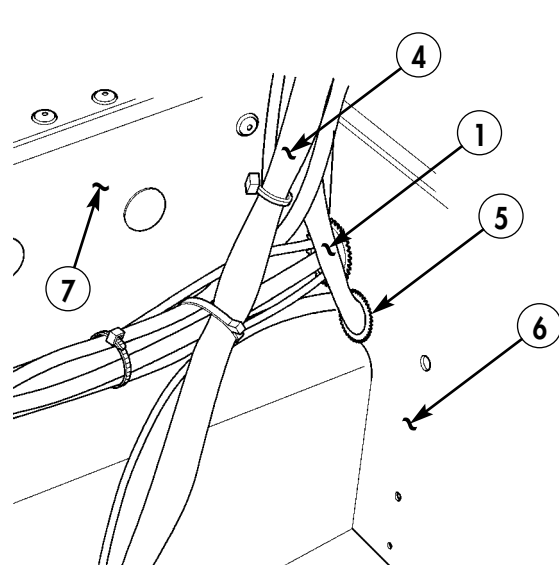

Figure 5-108.

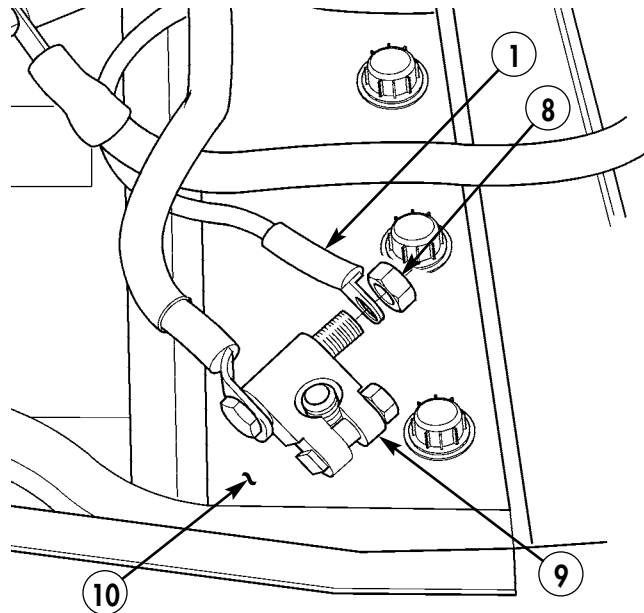
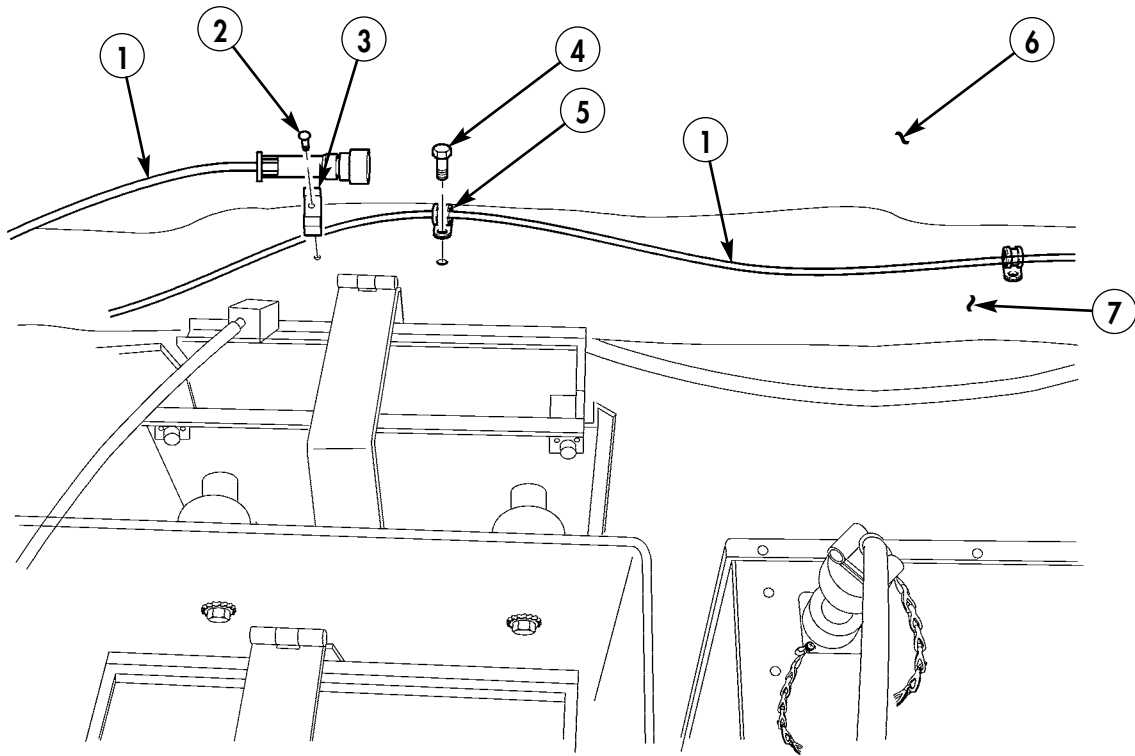

Figure 5-109.

Section XXXVII. REMOTE CURBSIDE SEPARATOR CABLE INSTALLATION

37-1. Route EPLRS radio Ethernet cable (1) along C-pillar (7) of roof (6).

37-2. Secure EPLRS radio Ethernet cable (1) to C-pillar (7) with screw (2), cable block (3), two clamps (5), and screws (4).



- 1. EPLRS RADIO ETHERNET CABLE - A3265725 - QTY. 1
- 2. SCREW - MS90728-6 - QTY. 1
- 3. CABLE BLOCK - 7565K51 - QTY. 1
- 4. SCREW - 9421073 - QTY. 2
- 5. LOOP CLAMP - MS21333-75 - QTY. 2

Figure 5-110.

37-3. Route EPLRS radio antenna cable (8) along C-pillar (7) of roof (6).

37-4. Secure EPLRS radio antenna cable (8) to C-pillar (7) with clamp (9) and screw (4).

37-5. Route EPLRS radio Ethernet cable (1) and EPLRS radio antenna cable (8) along roof (6) to curbside separator (10).

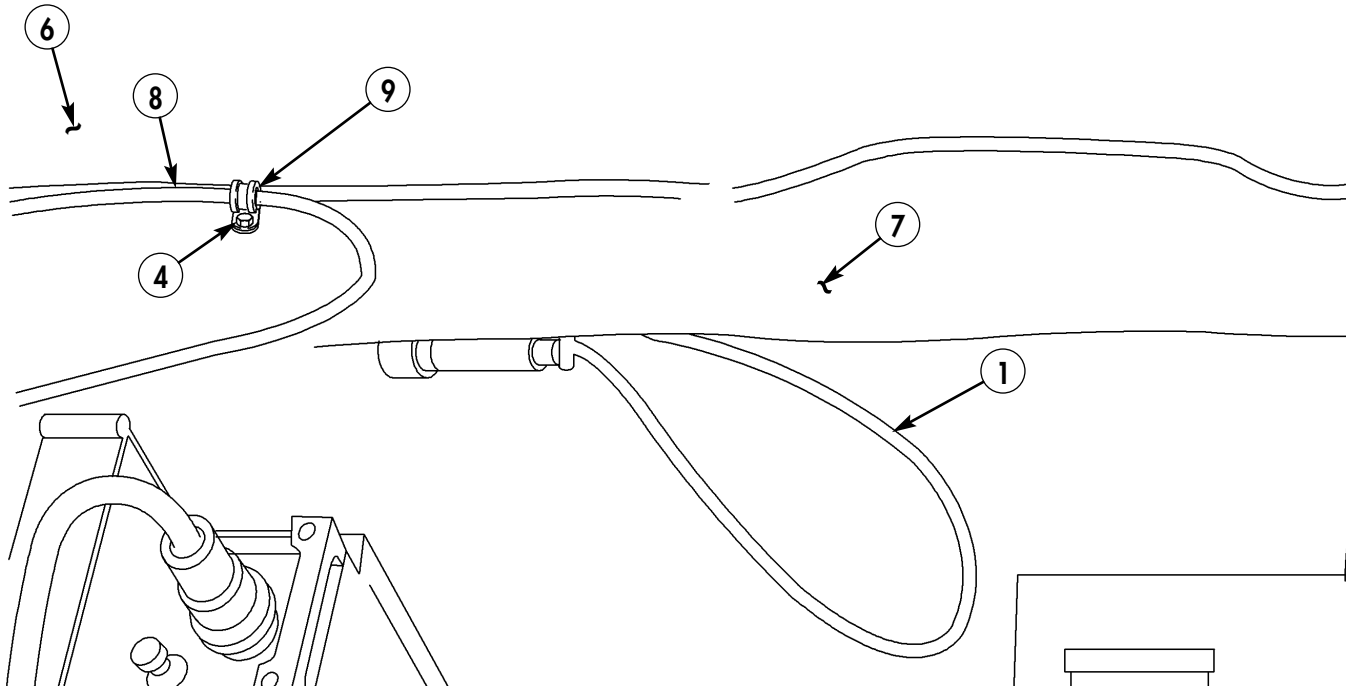

- 4. SCREW - 9421073 - QTY. 1
- 8. EPLRS RADIO ANTENNA CABLE - A3265727 - QTY. 1
- 9. CLAMP - MS21333-69 - QTY. 1

Figure 5-111.

- 37-6. Secure EPLRS radio Ethernet cable (1) to roof (6) with three clamps (5) and screws (4).
- 37-7. Secure EPLRS radio antenna cable (8) to roof (6) and C pillar (7) with four clamps (9) and screws (4).
- 37-8. Connect EPLRS radio Ethernet cable (1) to connector (11) on curbside separator (10).
- 37-9. Connect EPLRS radio antenna cable (8) to connector (12) on curbside separator (10).

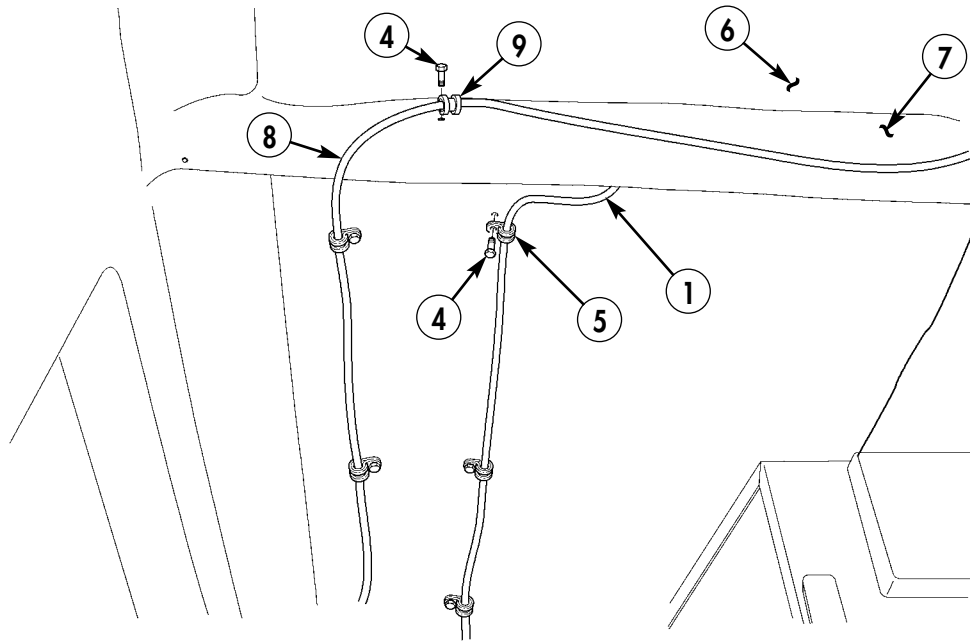

- 4. SCREW - 9421073 - QTY. 7
- 5. CLAMP - MS21333-75 - QTY. 3
- 9. CLAMP - MS21333-69 - QTY. 4

Figure 5-112.

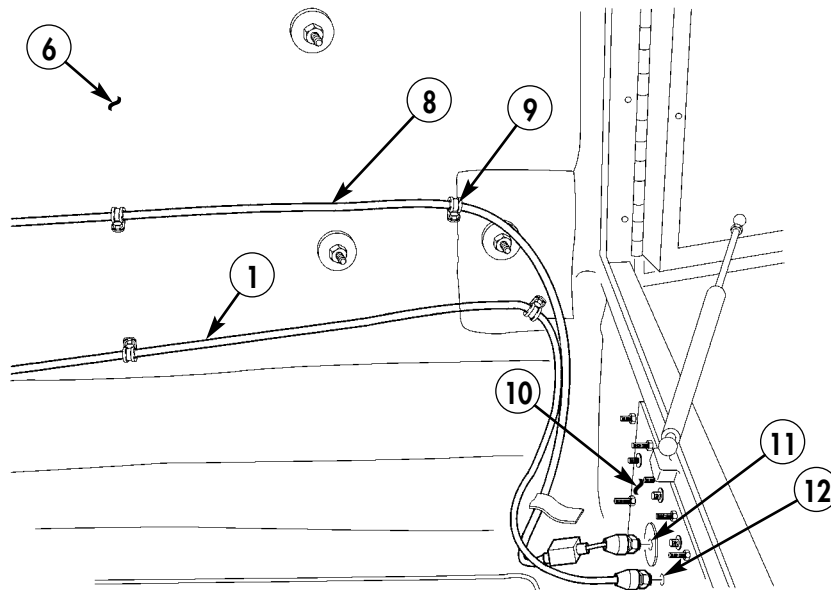
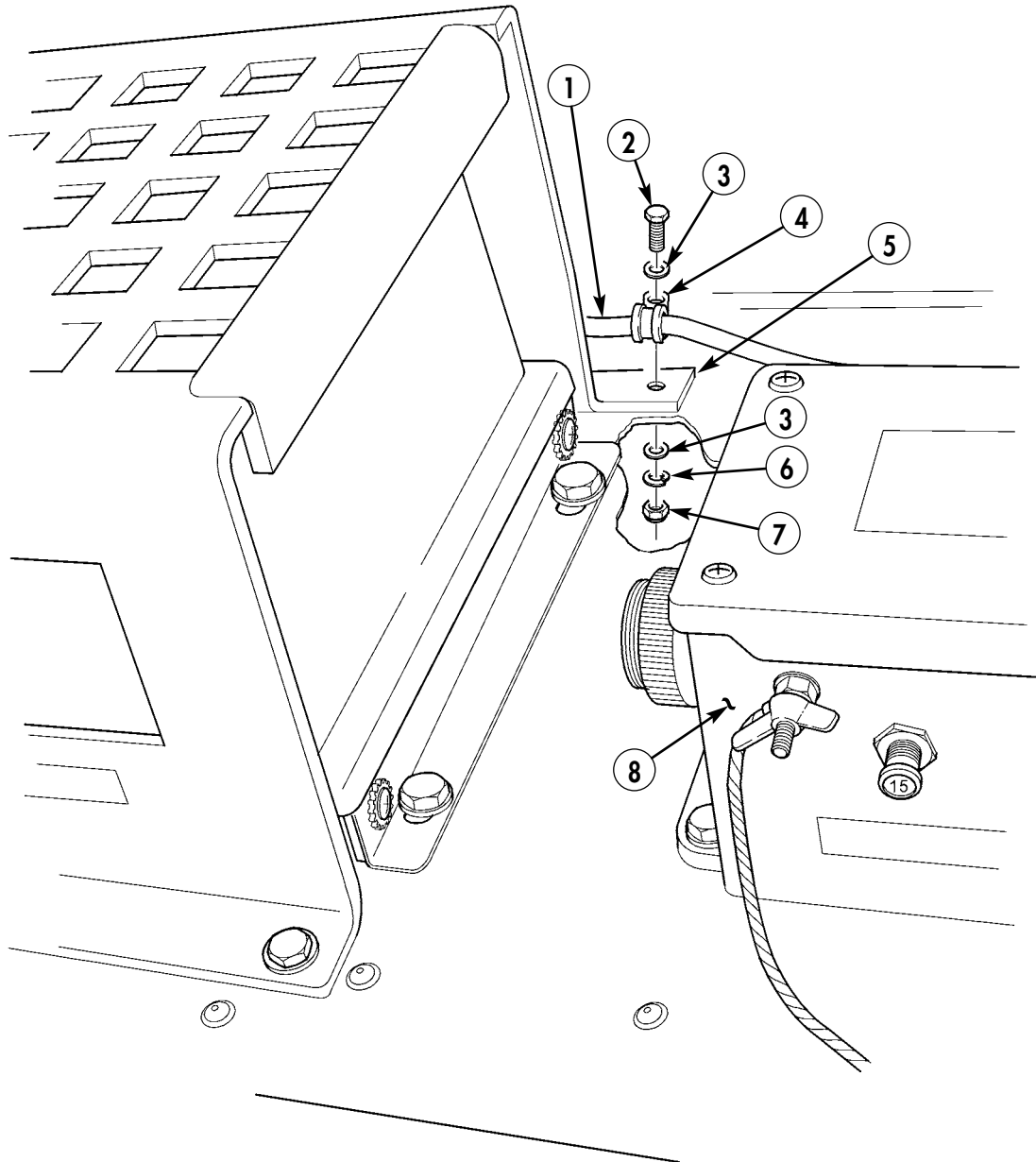

Figure 5-113.

Section XXXVIII. EXTERNAL POWER RECEPTION BOX CABLE INSTALLATION

- 38-1.** Route DC charger cable (1) to external power reception box (8).
- 38-2.** Secure DC charger cable (1) to DC charger guard (5), with loop clamp (4), existing screw (2), washer (3), lockwasher (6), and nut (7).



- 1. DC CHARGER CABLE – P/O 93-WP40-A – QTY. 1**
4. LOOP CLAMP – 3225T43 – QTY. 1

Figure 5-114.

38-3. Connect DC charger cable (1) to external power reception box (8).

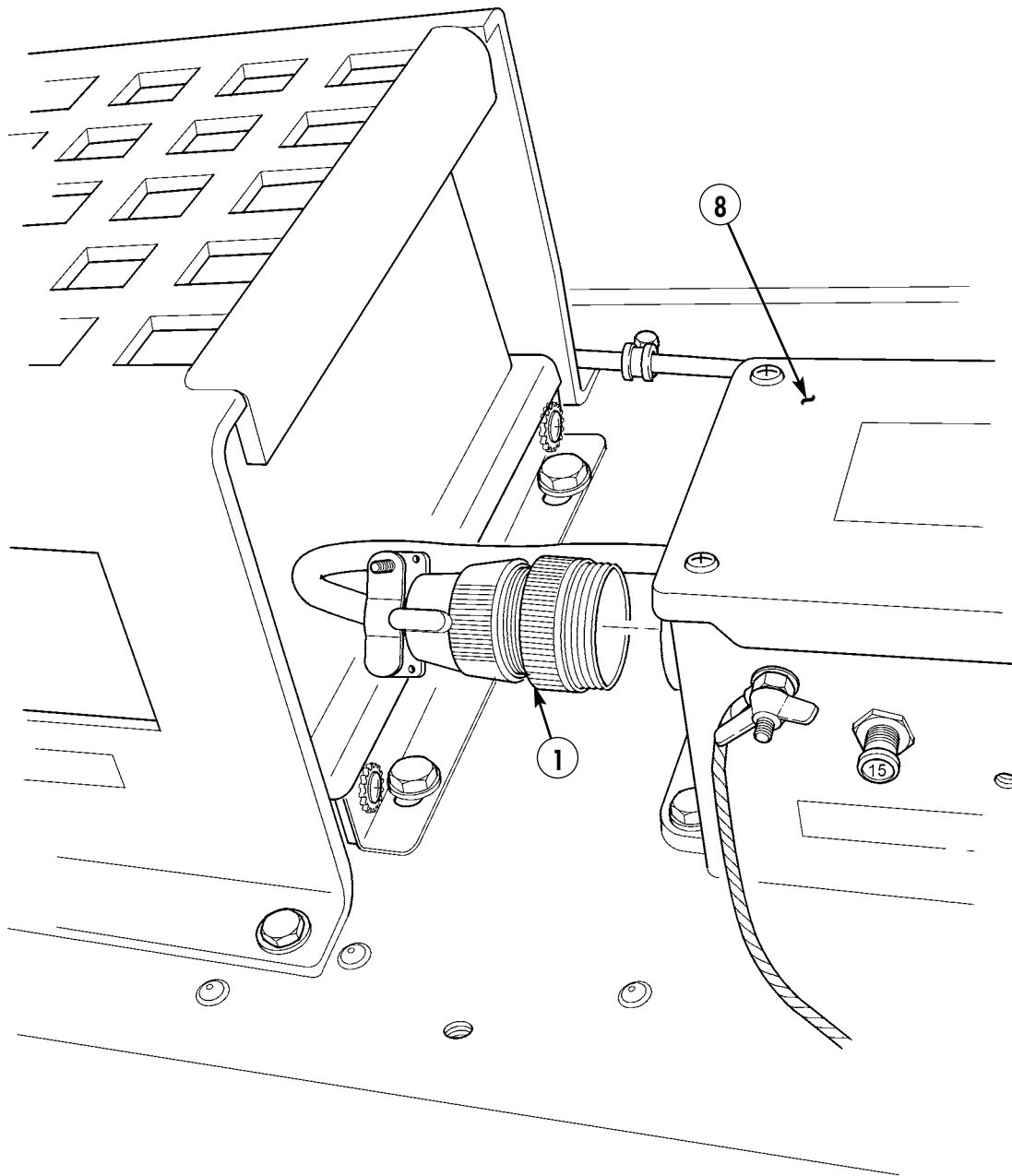
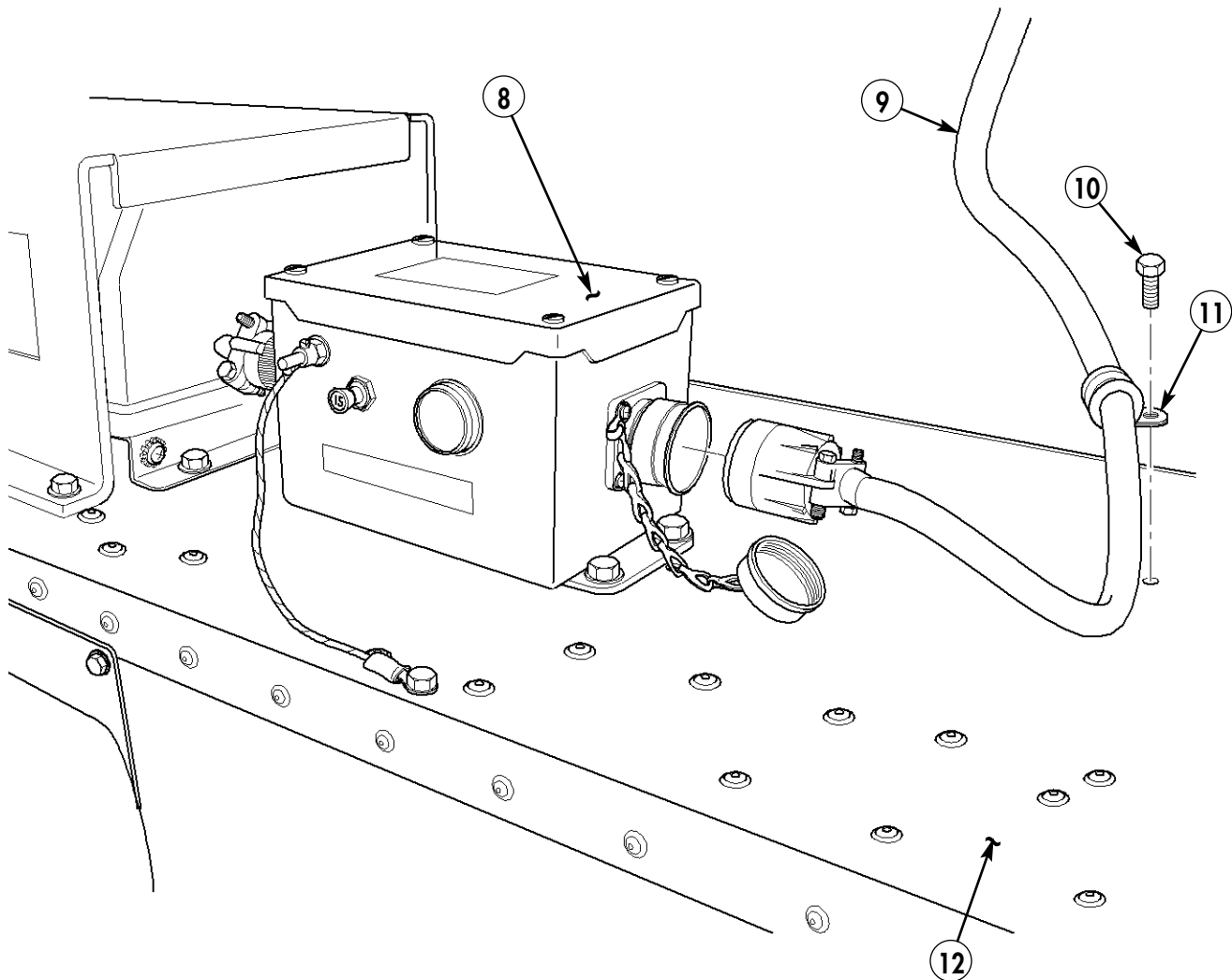

Figure 5-115.

38-4. Connect external power reception box cable (9) to external power reception box (8).

38-5. Secure external power reception box cable (9) to wheelhouse (12) with clamp (11) and screw (10).



- 9. EXTERNAL POWER RECEPTION BOX CABLE - A3265729 - QTY. 1
- 10. SCREW - 9421073 - QTY. 1
- 11. CLAMP - 3225T43 - QTY. 1

Figure 5-116.

Section XXXIX. DC CHARGER CABLE INSTALLATION

- 39-1.** Route DC charger cables (4) along wheelhouse (7) top, from DC charger (6), to battery box.
- 39-2.** Secure DC charger cables (4) to wheelhouse (7) top, with three clamps (3), three screws (1), six washers (2), three lockwashers (9), three nuts (8) and three tie straps (5).
- 39-3.** Secure DC charger cables (4) to wheelhouse (7) front, with two clamps (3), screws (1), washers (2), lockwashers (9), nuts (8), and tie straps (5).

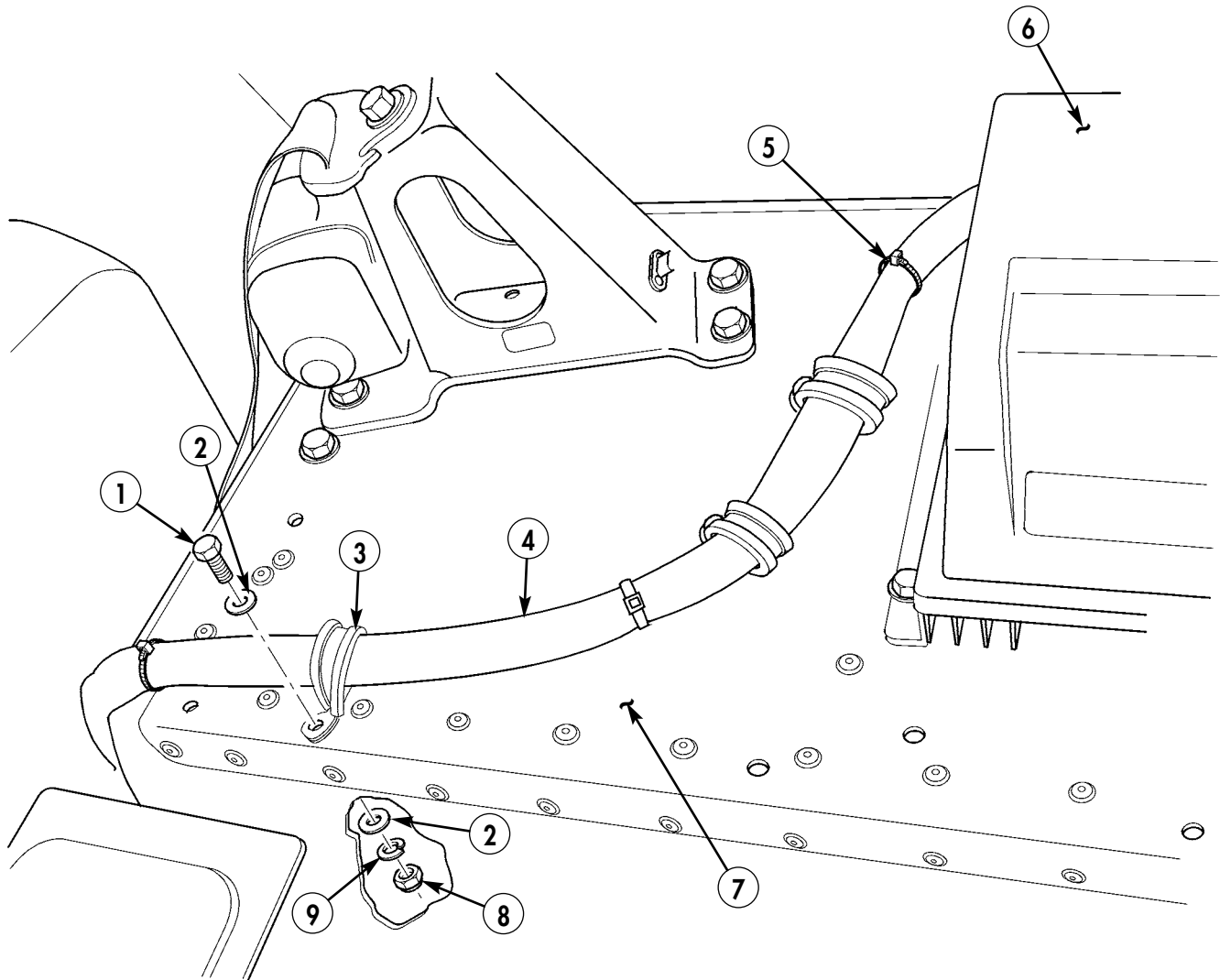

- 1. SCREW – MS90725-8 – QTY. 3
- 2. WASHER – MS27183-10 – QTY. 6
- 3. LOOP CLAMP – 3225T48 – QTY. 3
- 4. DC CHARGER CABLE – P/O 93-WP40-A – QTY. 1
- 5. TIE STRAP – MS3367-1-0 – QTY. A/R
- 8. NUT – MS51967-2 – QTY. 3
- 9. LOCKWASHER – MS35338-44 – QTY. 3

Figure 5-117.

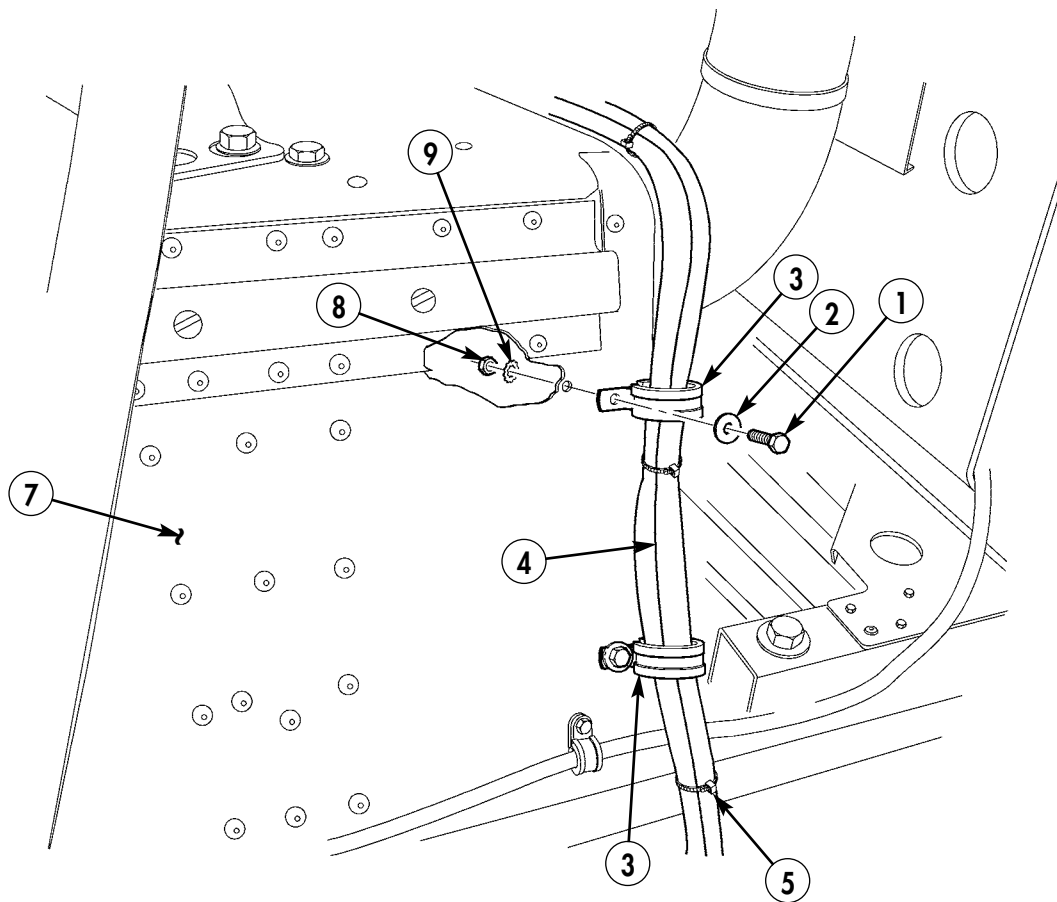

1. SCREW - MS90725-8 - QTY. 2
2. WASHER - MS27183-10 - QTY. 2
3. LOOP CLAMP - 3225T48 - QTY. 2
5. TIE STRAP - MS3367-1-0 - QTY. A/R
8. NUT - MS51967-2 - QTY. 2
9. LOCKWASHER - MS45904-68 - QTY. 2

Figure 5-118.

Section XL. AC DISTRIBUTION BOX CABLE INSTALLATION

- 40-1. Route AC distribution box cable (2) to AC output selection box (13).
- 40-2. Secure AC distribution box cable (2) to wheelhouse (3) with five clamps (9), screws (8), washers (10), lockwashers (11), and nuts (12).
- 40-3. Secure prosine inverter output cable (7) to AC distribution box cable (2) with three tie straps (6).
- 40-4. Connect KOK-13 power cable (4) and printer power cable (5) to AC distribution box (1).

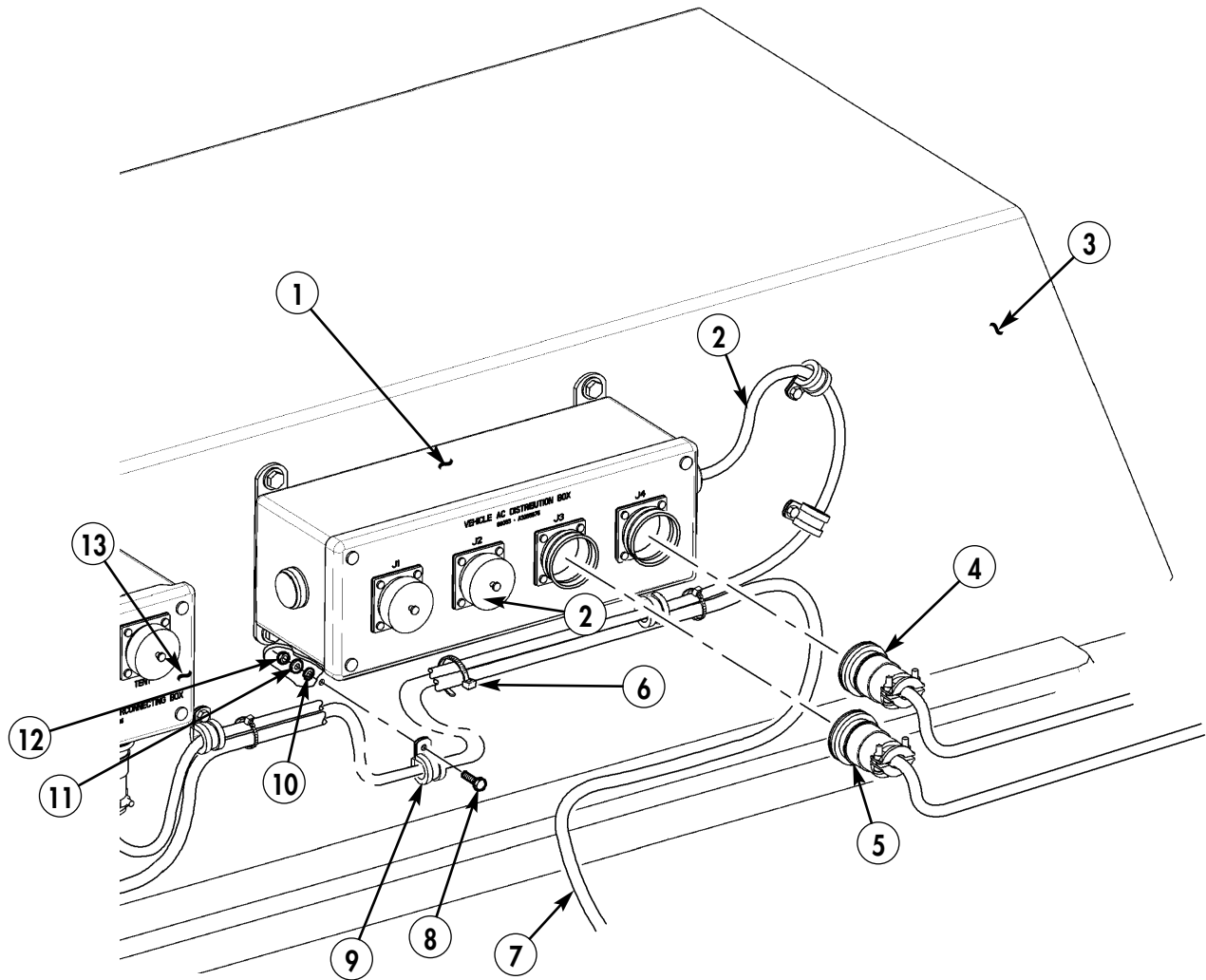

- 2. AC DISTRIBUTION BOX CABLE - P/O A3265676 - QTY. 1
- 4. KOK-13 POWER CABLE - A3265651 - QTY. 1
- 5. PRINTER AC POWER CABLE - A3265673 - QTY. 1
- 6. TIE STRAP - MS3367-1-0 - QTY. 3
- 7. PROSINE INVERTER OUTPUT CABLE - A3265674 - QTY. 1
- 8. SCREW - MS90725-8 - QTY. 5
- 9. LOOP CLAMP - 3225T46 - QTY. 5
- 10. WASHER - MS27183-10 - QTY. 5
- 11. LOCKWASHER - MS35338-44 - QTY. 5
- 12. NUT - MS51967-2 - QTY. 5

Figure 5-119.

Section XII. AC OUTPUT SELECTION BOX CABLE INSTALLATION

- 41-1. Route AC output selection box cable (1) from roadside separator connector (2) to AC output selection box (4).
- 41-2. Secure AC output selection box cable (1) to wheelhouse (7) with two clamps (3), screws (5), and washers (6).
- 41-3. Connect AC output selection box cable (1) to AC output selection box (4).
- 41-4. Connect AC distribution box cable (8) and prosine inverter output cable (9) to AC output selection box (4).

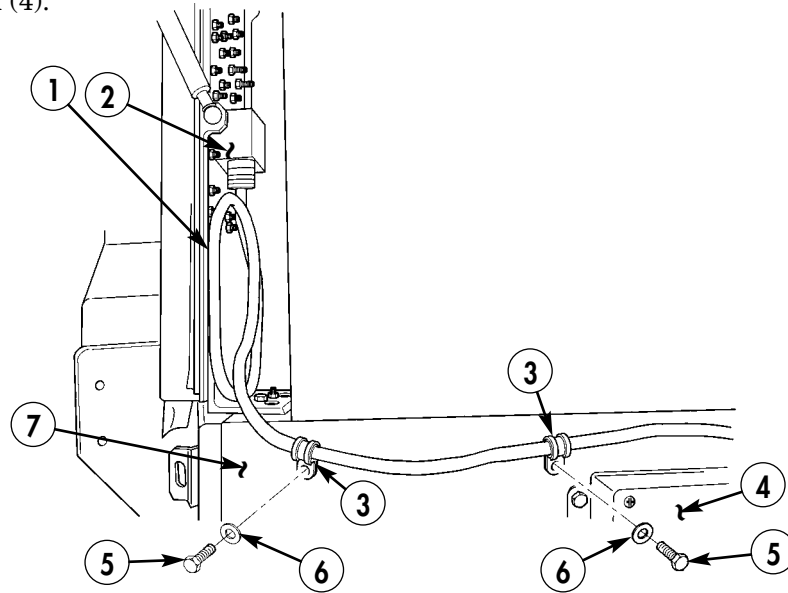

- 1. OUTPUT POWER SELECTION BOX CABLE – A3265726 – QTY. 1
- 3. LOOP CLAMP – 3225T46 – QTY. 2
- 5. SCREW – 9421073 – QTY. 2
- 6. WASHER – MS27183-10 – QTY. 2

Figure 5-120.

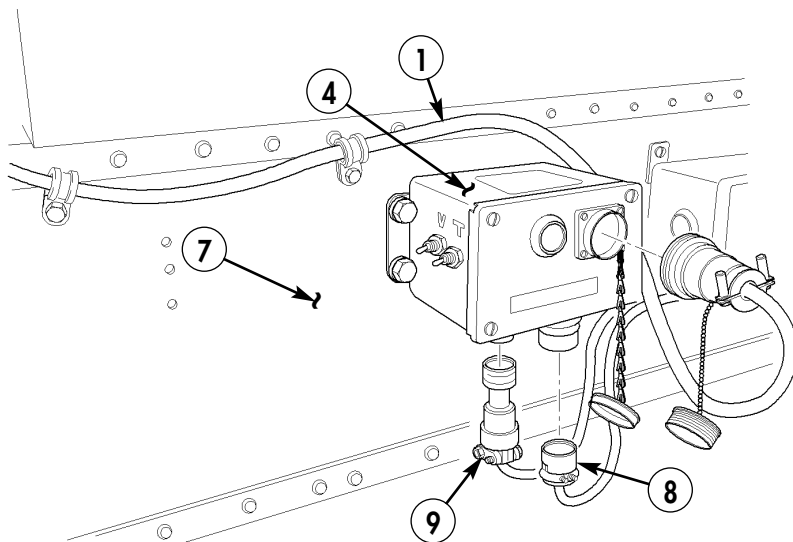
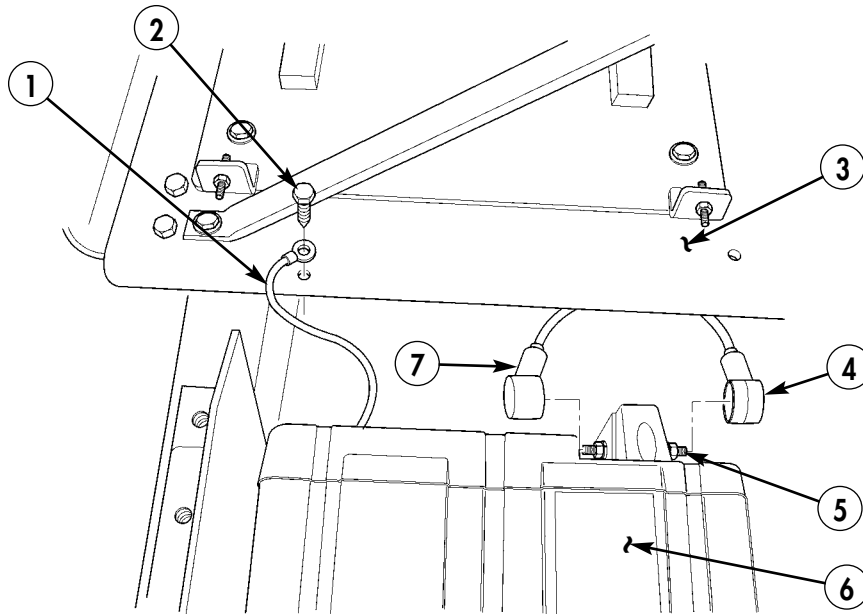

Figure 5-121.

Section XLII. INVERTER CABLE INSTALLATION

- 42-1. Connect inverter ground wire (1) to multi-net rack (3) lower shelf with self-tapping screw (2).
- 42-2. Install positive inverter cable (4) and negative inverter cable (7) to inverter (6) with existing nuts (5).
- 42-3. Route inverter output cable (8) between inverter (6) and inverter side wall (9) and connect inverter output cable (8) to inverter (6).



- 1. GROUND WIRE – P/O 806-1050 – QTY. 1
- 2. SELF-TAPPING SCREW – 9421073 – QTY. 1
- 4. INVERTER POSITIVE CABLE – A3265730 – QTY. 1
- 7. INVERTER NEGATIVE CABLE – A3265692 – QTY. 1

Figure 5-122.

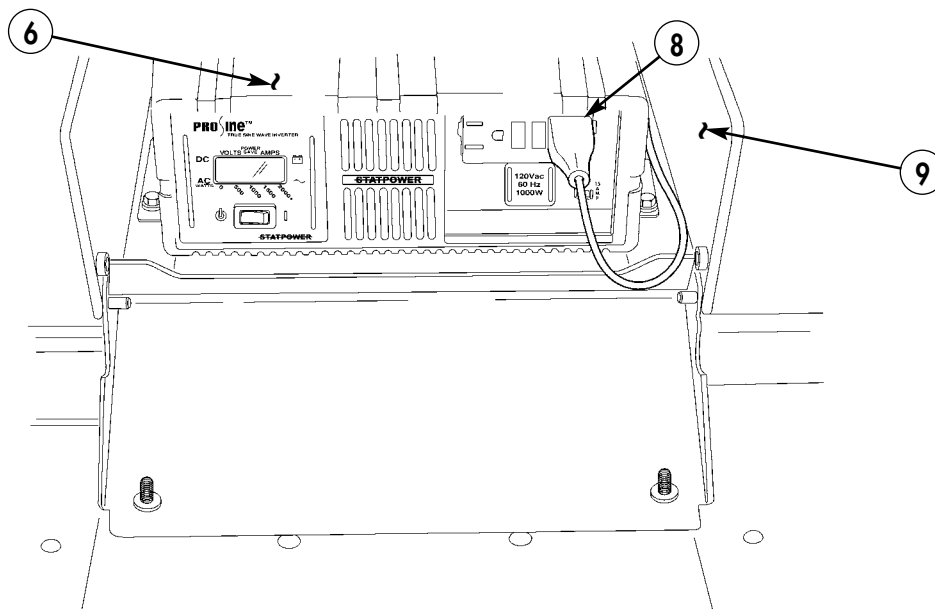
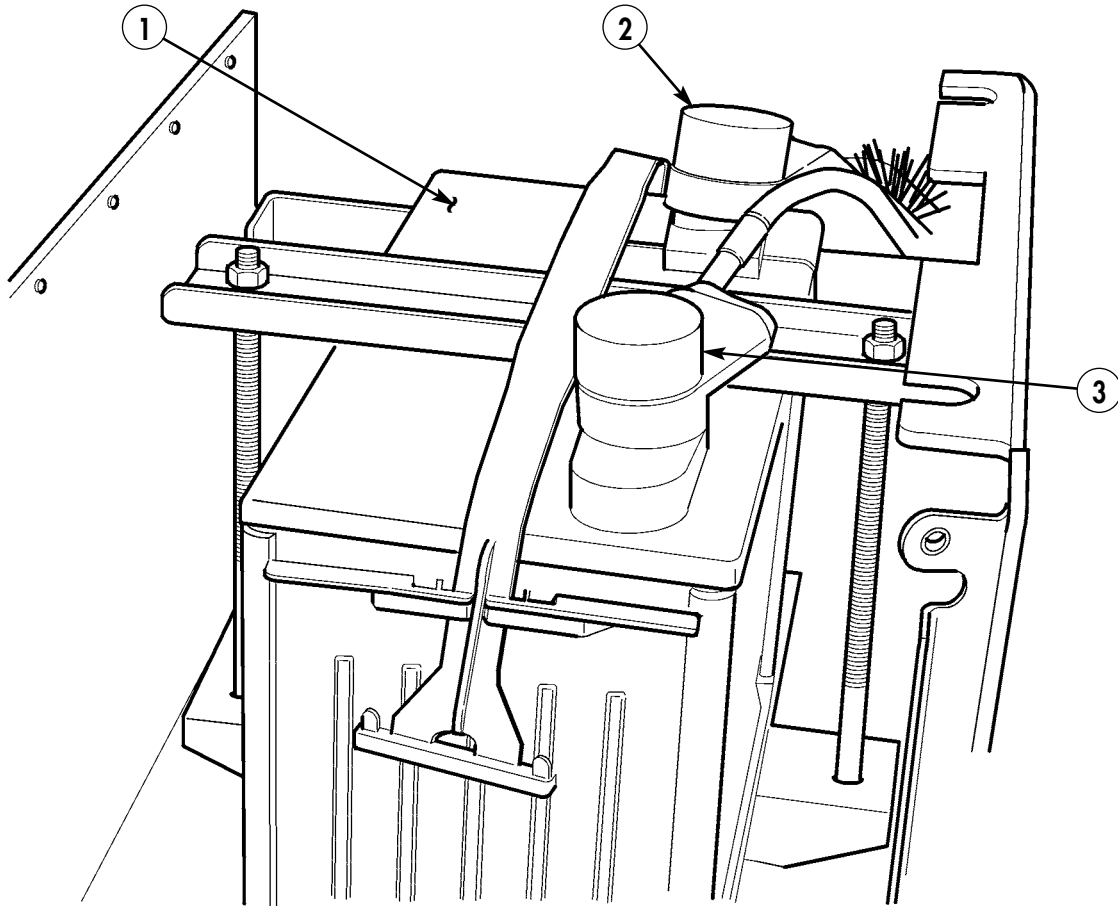

Figure 5-123.

Section XLIII. REAR BATTERY CABLE INSTALLATION

- 43-1.** Connect negative battery cable (2) and positive battery cable (3) to rear battery (1) with two existing nuts.



- 2. NEGATIVE BATTERY CABLE – A3265734 – QTY. 1**
3. POSITIVE BATTERY CABLE – A3265733 – QTY. 1

Figure 5-124.

Section XLIV. MULTI-NET RACK REAR CABLE INSTALLATION

- 44-1. Route EPLRS power cables (1) from EPLRS mounts (2) down multi-net rack (6) on left side.
- 44-2. Route INC-EPUU cable (3) from EPLRS mount (2) to underside of multi-net rack (6) upper shelf.
- 44-3. Connect printer AC power cable (4) to printer (5).
- 44-4. Locate, mark, and drill two 0.147-in. diameter holes (7) in multi-net rack (6).
- 44-5. Locate, mark, and drill two 0.281-in. diameter holes (8) in multi-net rack (6).

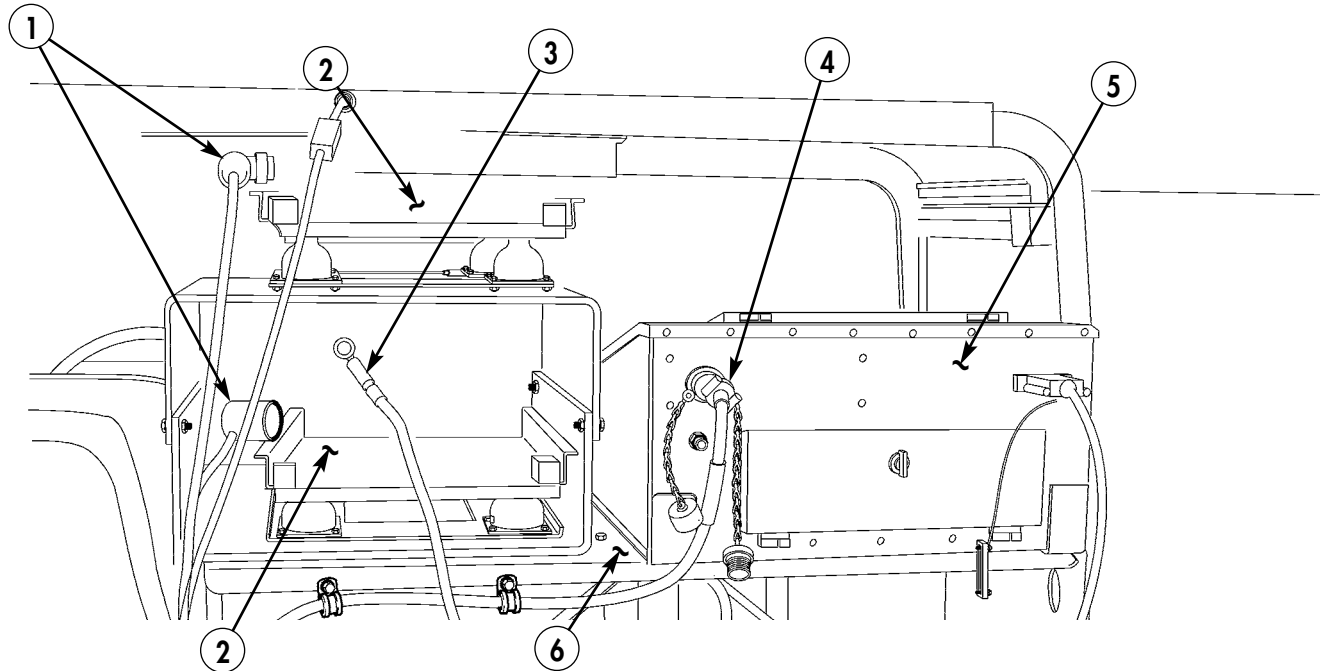

1. EPLRS POWER CABLE – A3004939 – QTY. 2

Figure 5-125.

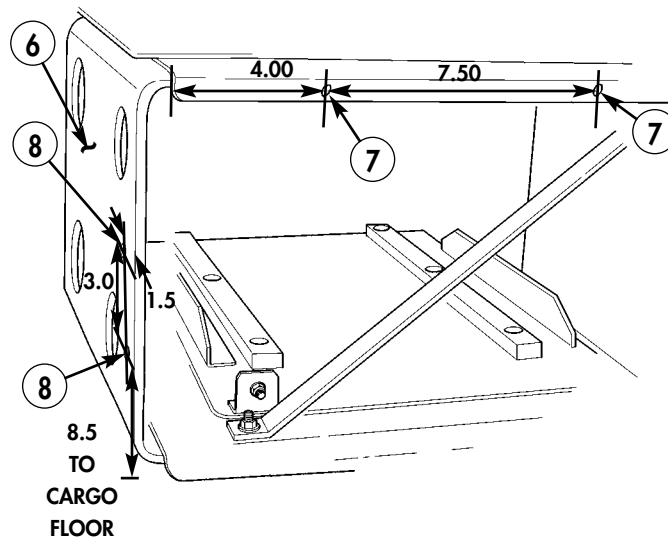
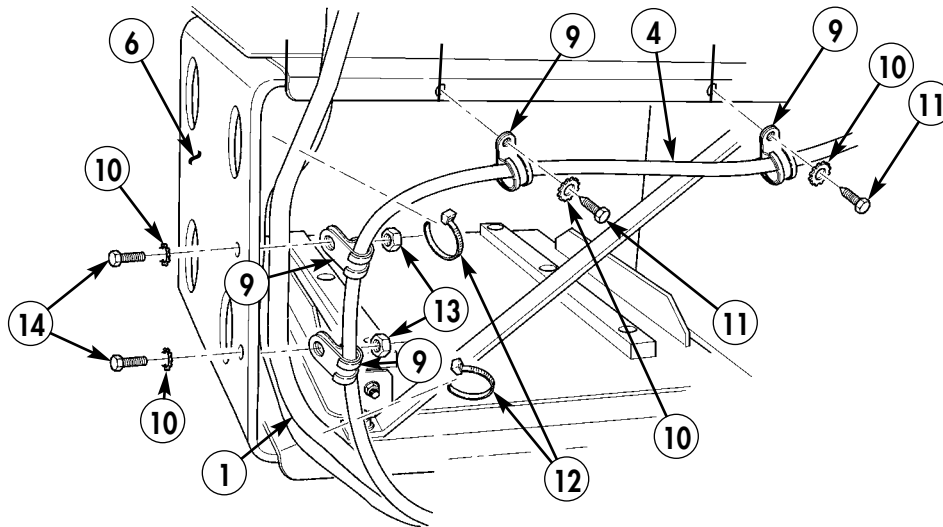

Figure 5-126.

- 44-6. Secure printer AC power cable (4) to multi-net rack (6) upper shelf with two screws (11), lockwashers (10), and clamps (9).
- 44-7. Secure printer AC power cable (4) along side of multi-net rack (6) with two screws (14), lockwashers (10), clamps (9), and nuts (13).
- 44-8. Secure two EPLRS power cables (1) to printer AC power cable (4), with two tie straps (12).
- 44-9. Place KOK-13 power cable (15) on KOK-13 mount (16).



- | | |
|--------------------------------------|---------------------------------------|
| 9. LOOP CLAMP – MS21333-69 – QTY. 4 | 12. TIE STRAP – MS3367-1-0 – QTY. A/R |
| 10. LOCKWASHER – MS45904-60 – QTY. 4 | 13. NUT – MS35650-302 – QTY. 2 |
| 11. SCREW – 9421073 – QTY. 2 | 14. SCREW – MS35207-267 – QTY. 2 |

Figure 5-127.

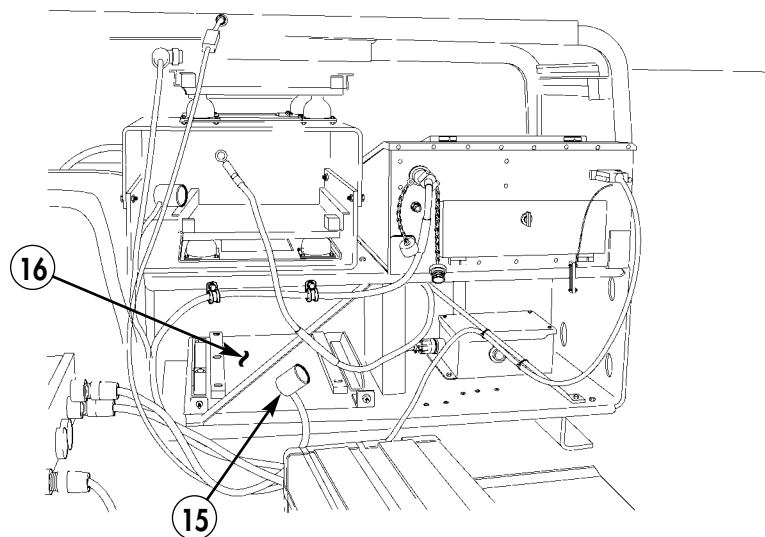
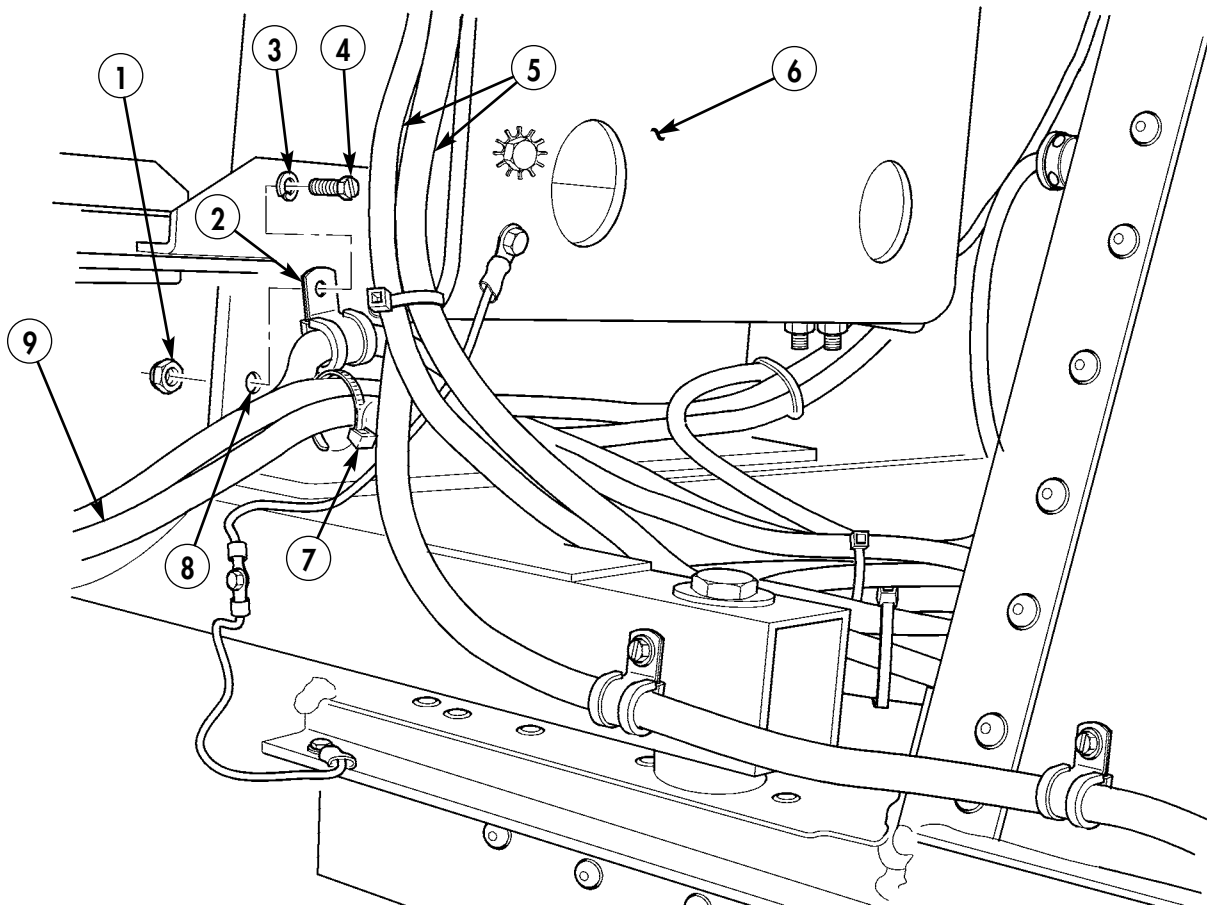

Figure 5-128.

Section XLV. DRIVER-SIDE MULTI-NET RACK CABLE INSTALLATION

- 45-1. Locate two existing 0.281-in. diameter holes (8) in multi-net rack (6) support.
- 45-2. Locate, mark, and drill three 0.147-in. diameter holes (10) in multi-net frame (11).
- 45-3. Route two URO extension cables (5) and two EPLRS power cables (9) from multi-net rack (6) support along multi-net frame (11) to curbside footwell.
- 45-4. Secure one EPLRS power cable (9) to multi-net rack (6) support with two clamps (2), screws (4), lockwashers (3), and nuts (1).
- 45-5. Secure one EPLRS power cable (9) to multi-net frame (11) with three clamps (2) and screws (12).
- 45-6. Secure two URO extension cables (5) and remaining EPLRS power cable (9) to previously secured EPLRS power cable (9) with tie straps (7).



- 1. SCREW – MS90725-6 – QTY. 2
- 2. LOOP CLAMP – 3225T46 – QTY. 4
- 3. LOCKWASHER – MS35338-44 – QTY. 2
- 7. TIE STRAP – MS3367-1-0 – QTY. A/R

Figure 5-129.

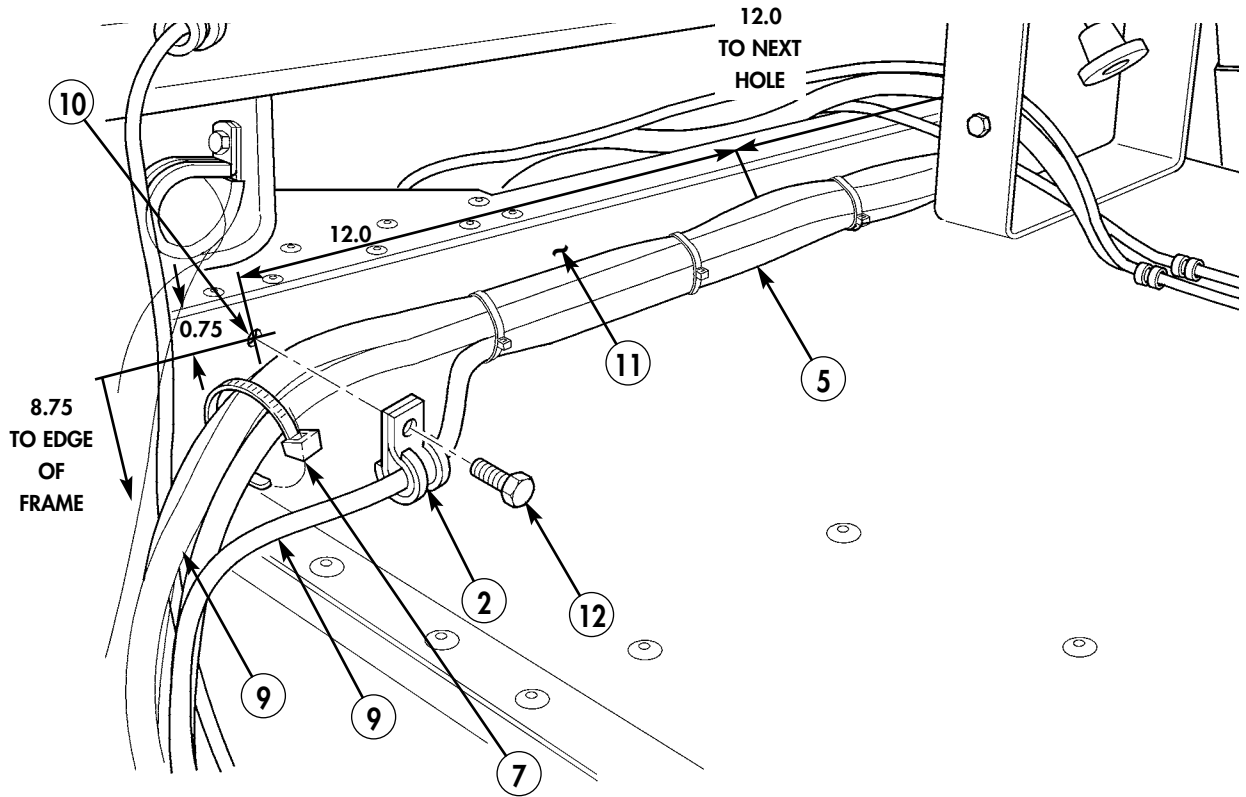

- 2. LOOP CLAMP - 3225T46 - QTY. 3
- 7. TIE STRAP - MS3367-1-0 - QTY. A/R
- 12. SCREW - 9421073 - QTY. 3

Figure 5-130.

45-7. Locate, mark, and drill three 0.147-in. diameter holes (14) in multi-net rack (6).

45-8. Secure two ground straps (16) to multi-net rack (6) and EPLRS dual mount (17) with three screws (12) and lockwashers (15).

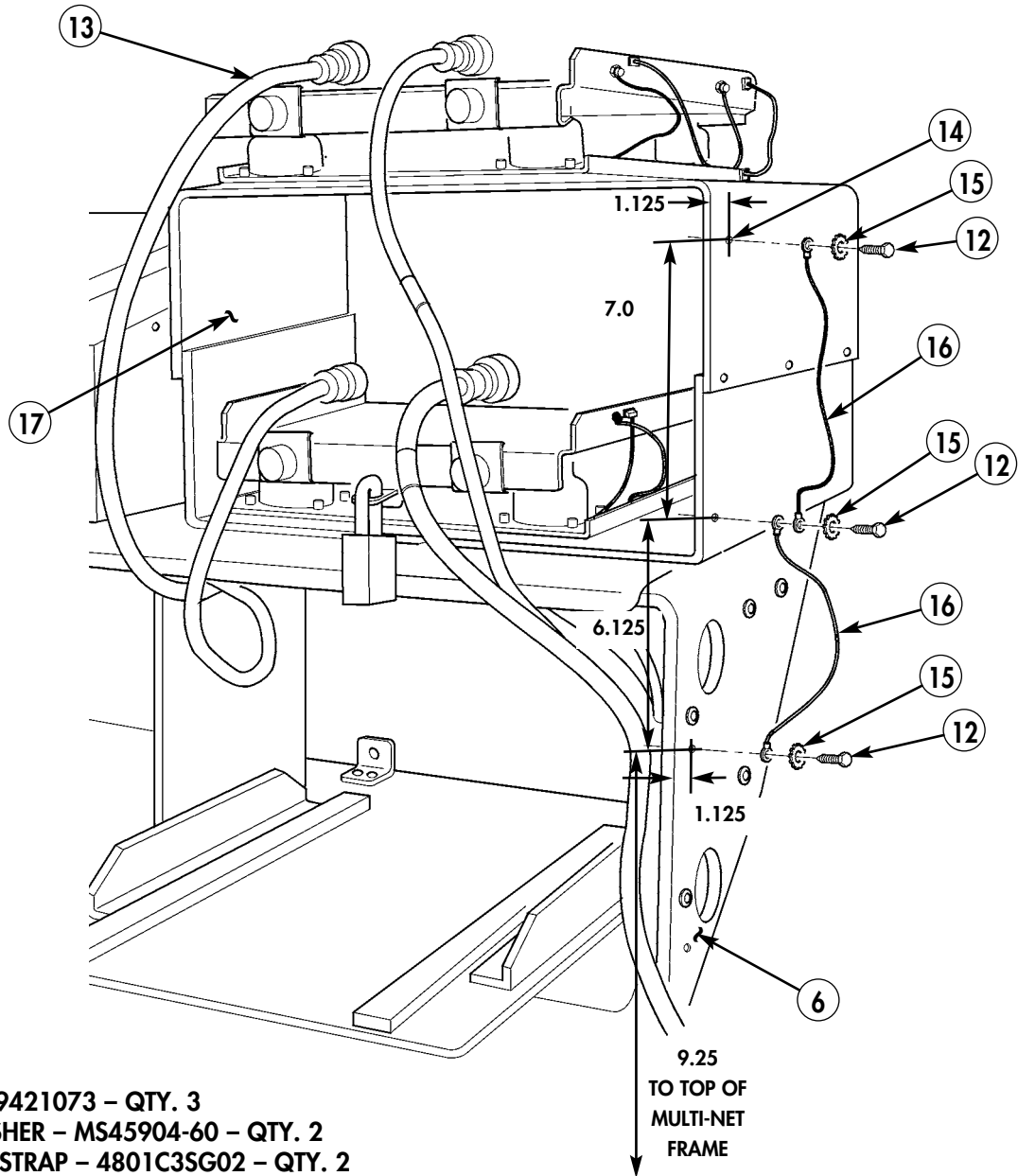

- 12. SCREW - 9421073 - QTY. 3
- 15. LOCKWASHER - MS45904-60 - QTY. 2
- 16. GROUND STRAP - 4801C3SG02 - QTY. 2

Figure 5-131.

45-9. Secure EPLRS driver-side antenna cable (13) to multi-net rack (6) with four clamps (20), four screws (18), eight lockwashers (19), and four nuts (21).

45-10. Secure URO extension cables (5) to EPLRS driver-side antenna cable (22) with tie straps (7).

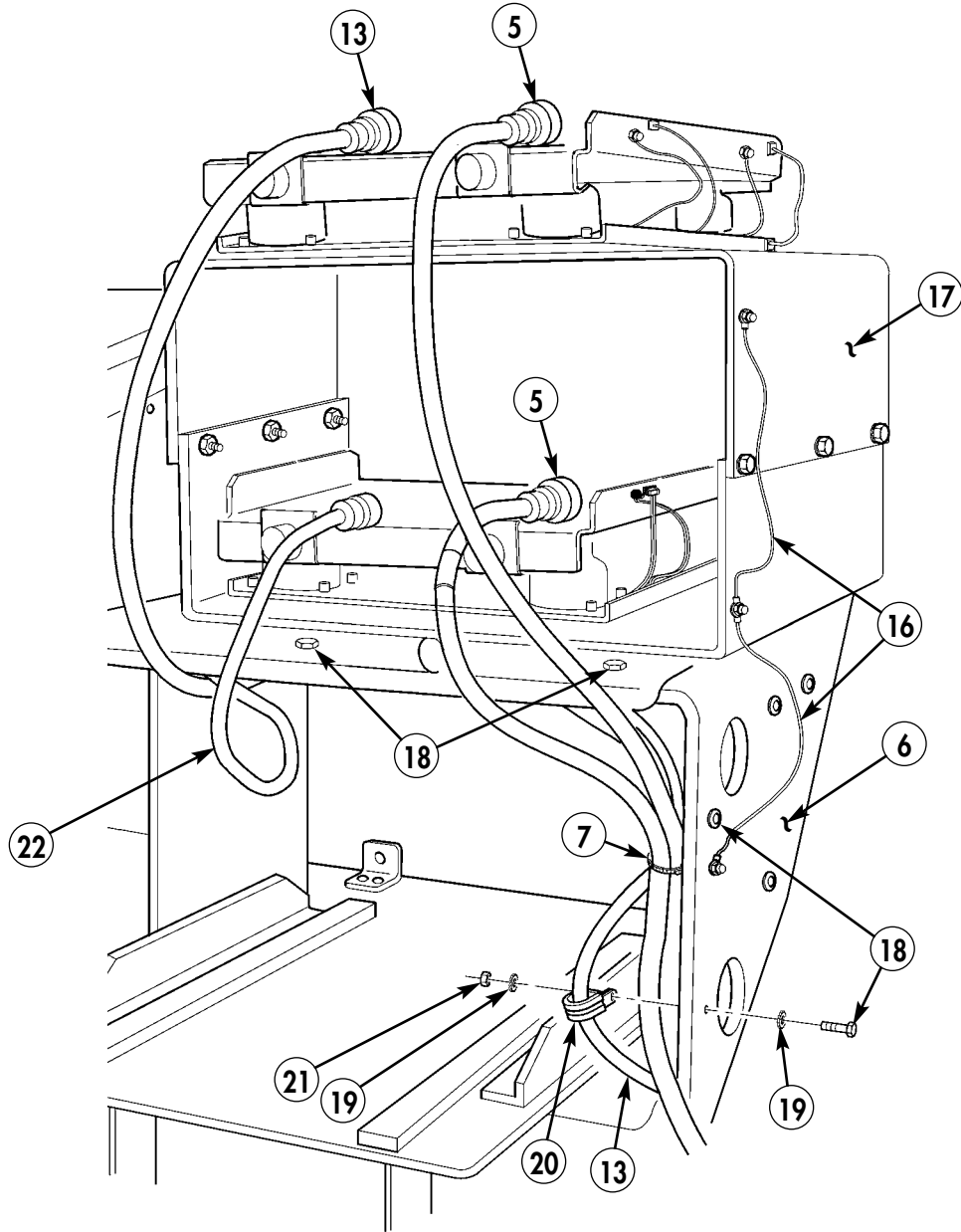

- 7. TIE STRAP – MS3367-1-0 – QTY. A/R
- 18. SCREW – MS90725-8 – QTY. 4
- 19. LOCKWASHER – MS45904-68 – QTY. 8
- 20. LOOP CLAMP – MS21333-69 – QTY. 4
- 21. NUT – MS51967-2 – QTY. 4

Figure 5-132.

Section XLVI. PASSENGER-SIDE MULTI-NET RACK CABLE INSTALLATION

- 46-1. Locate, mark, and drill two 0.281-in. diameter holes (12) in multi-net rack (3).
- 46-2. Locate, mark, and drill two 0.281-in. diameter holes (13) in multi-net rack (3).
- 46-3. Connect battery alarm box power cable (10) to battery alarm box (9).
- 46-4. Route battery alarm box power cable (10) along multi-net rack (3) lower shelf to curbside footwell.
- 46-5. Secure battery alarm box power cable (10) with two clamps (11), screws (5), lockwashers (4), and nuts (8).
- 46-6. Route EPLRS antenna cable (1) and INC-EPUU cable (2) along underside of multi-net rack (3) upper shelf.
- 46-7. Secure EPLRS antenna cable (1) and INC-EPUU cable (2) to multi-net rack (3) with five clamps (7), screws (5), lockwashers (4), and nuts (8).

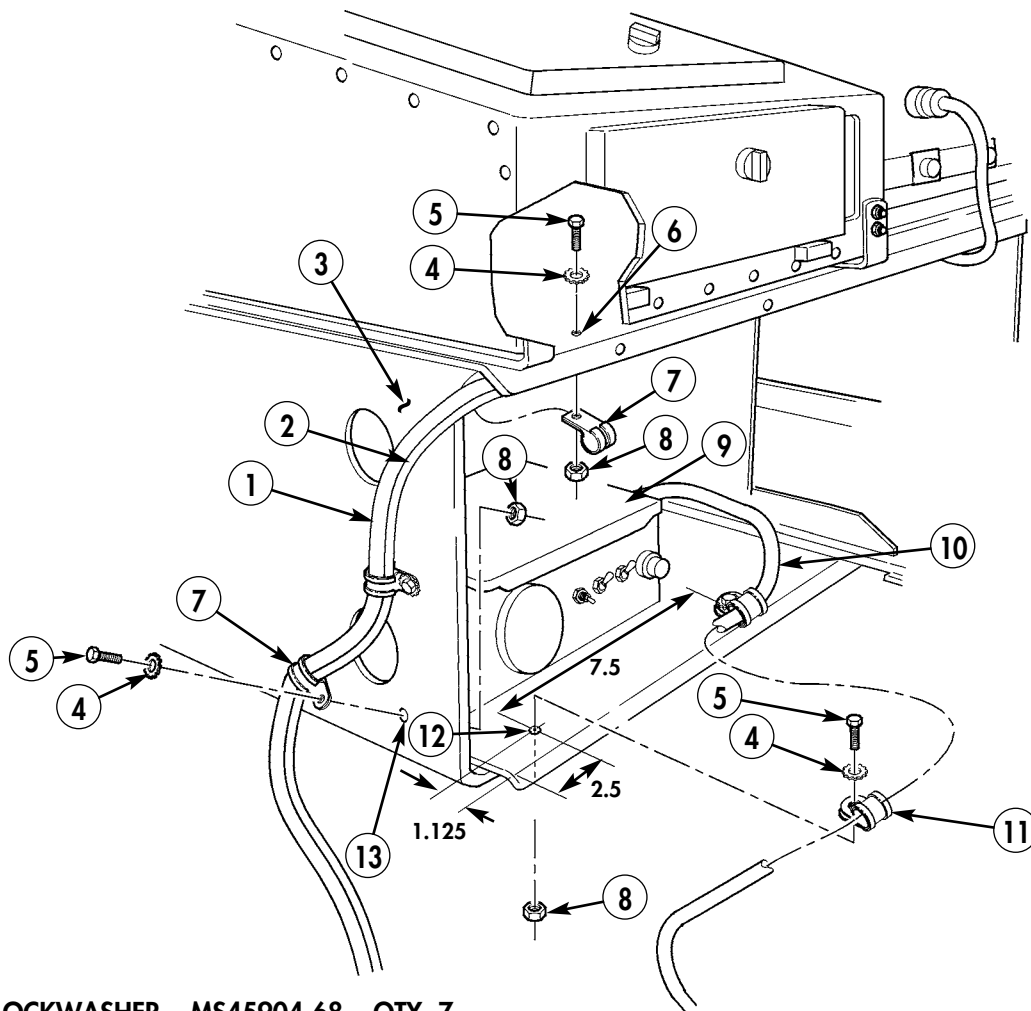

- 4. LOCKWASHER – MS45904-68 – QTY. 7
- 5. SCREW – MS90725-6 – QTY. 7
- 7. LOOP CLAMP – 3225T48 – QTY. 5
- 8. NUT – MS51967-2 – QTY. 7
- 10. BATTERY ALARM BOX CABLE – A3265596 – QTY. 1
- 11. LOOP CLAMP – MS21333-102 – QTY. 2

Figure 5-133.

- 46-8. Locate two existing 0.281-in. diameter holes (18) in multi-net rack (3) support.
- 46-9. Route Prosine inverter positive and negative cables (16) and rear battery positive and negative cables (17) from multi-net rack (3) support to curbside footwell.
- 46-10. Secure Prosine inverter positive and negative cables (16) and rear battery positive and negative cables (17) to multi-net rack (3) support with two clamps (7), screws (5), lockwashers (15), washers (14), and nuts (8).

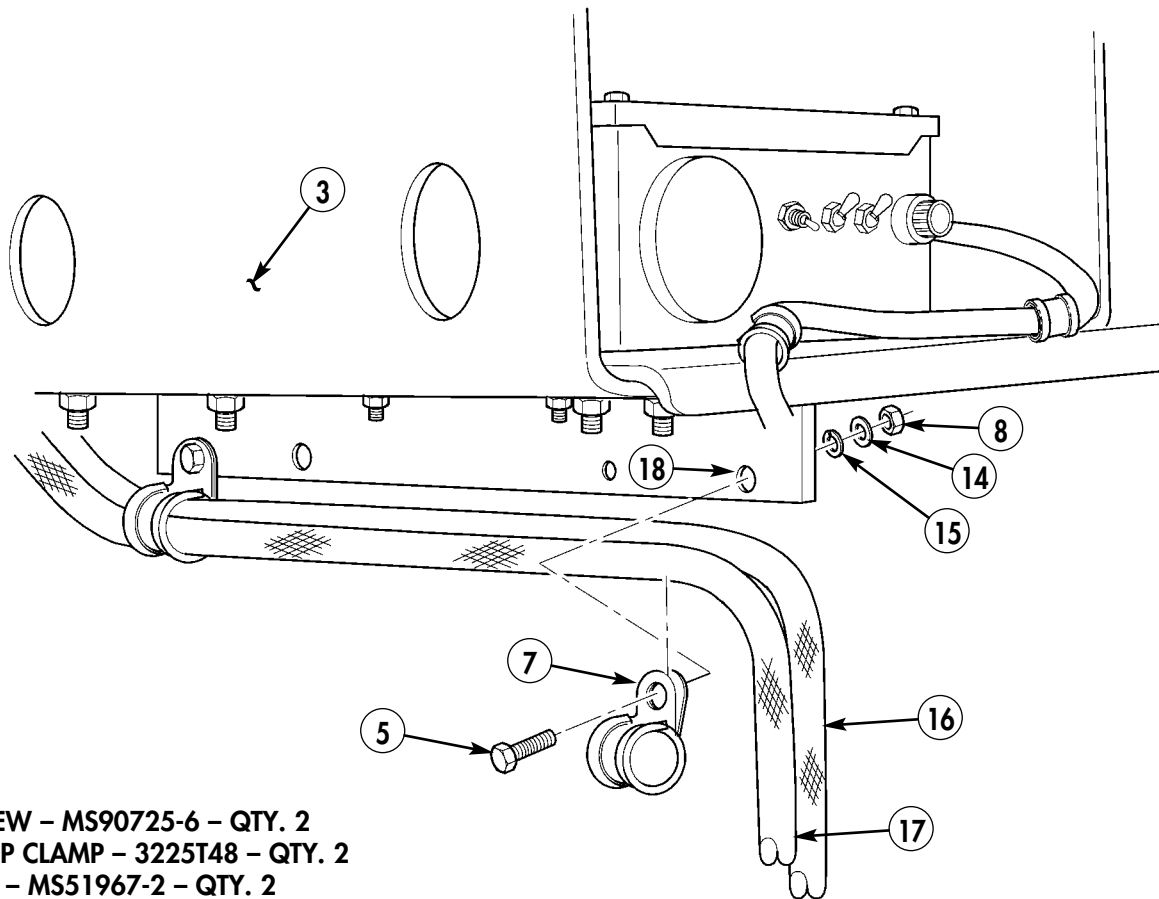

- 5. SCREW – MS90725-6 – QTY. 2
- 7. LOOP CLAMP – 3225T48 – QTY. 2
- 8. NUT – MS51967-2 – QTY. 2
- 14. WASHER – MS27183-12 – QTY. 2
- 15. LOCKWASHER – MS35338-44 – QTY. 2

Figure 5-134.

Section XLVII. C4ISR POWER CABLE INSTALLATION

- 47-1. Route DC charger cables (1) into access cutout (12) in vehicle body rail (11) and through grommets hole (10) in battery box (9) rear wall.
- 47-2. Route inverter positive and negative cables (2) into access cutout (12) in vehicle body rail (11) and through grommets hole (10) in battery box (9) rear wall.
- 47-3. Route rear battery positive and negative cables (3) into access cutout (12) in vehicle body rail (11) and through grommets hole (10) in battery box (9) rear wall.
- 47-4. Route DC adapter cable (6) along tunnel (13) into access cutout (12) in vehicle body rail (11) and through grommets hole (10) in battery box (9) rear wall.
- 47-5. Route PLGR power cable (8) along tunnel (13), along vehicle body rail (11), and down under battery box (9) right-side wall.
- 47-6. Route SINCGARS power cable (7) along tunnel (13), along vehicle body rail (11), and down under battery box (9) right-side wall.
- 47-7. Route EPLRS power cables (4) along cargo floor (5) to vehicle body rail (11) and down under battery box (9) right-side wall.

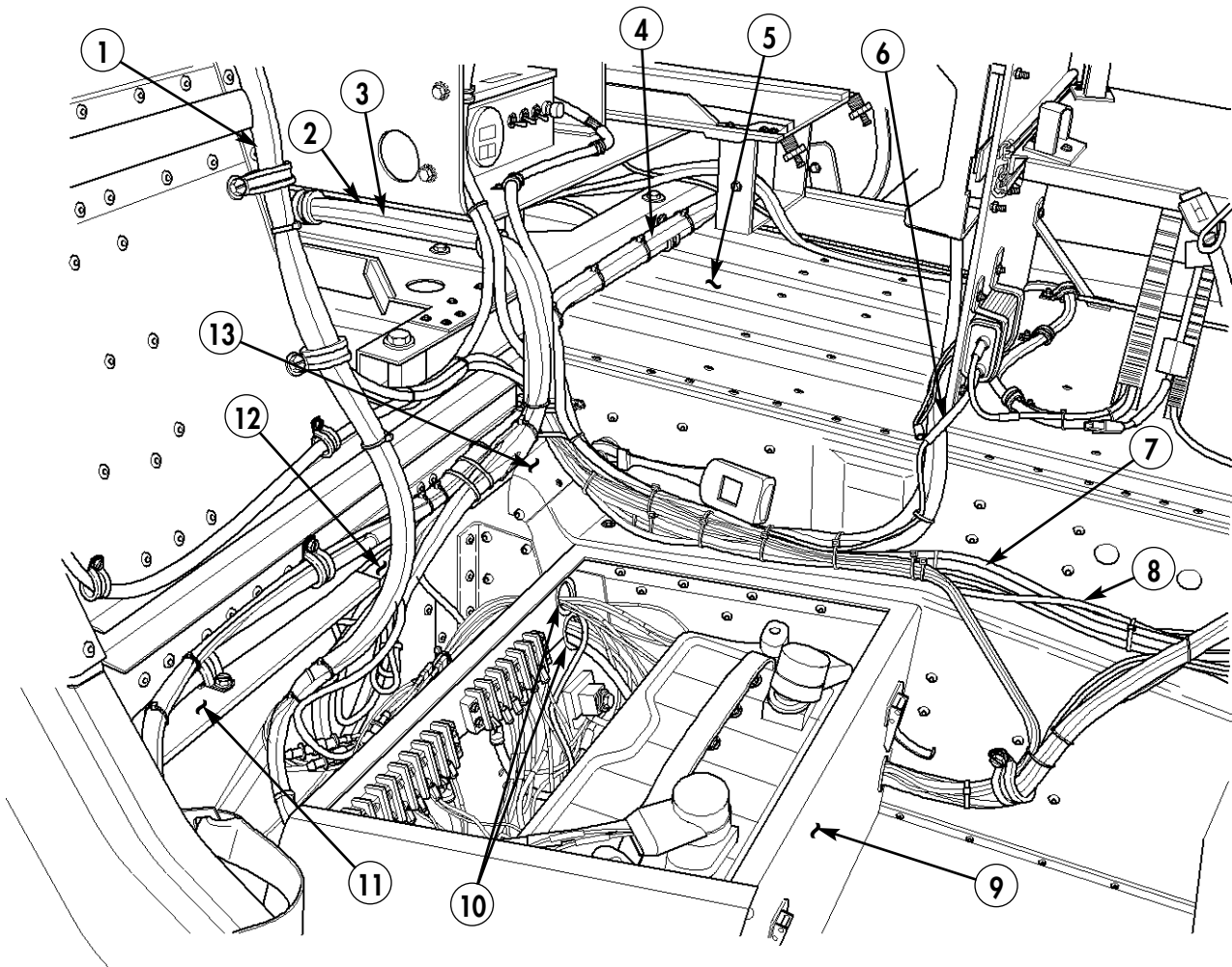

Figure 5-135.

- 47-8. Route battery alarm box cable (14) along tunnel (13) and down into grommeted hole (18) in battery box (9) forward wall.
- 47-9. Route master kill switch box cable (17) along tunnel (13) and down into grommeted hole (18) in battery box (9) forward wall.
- 47-10. Route INC-EPUU cable (15) through grommeted hole (19) in cab enclosure panel (20) and along tunnel (13) to multi-net rack.
- 47-11. Route shunt cable (21) through grommeted hole (19) in cab enclosure panel (20) to negative terminal of vehicle battery.
- 47-12. Route battery alarm box control cable (16) from battery box (9) through cab enclosure panel (20) to front of vehicle.

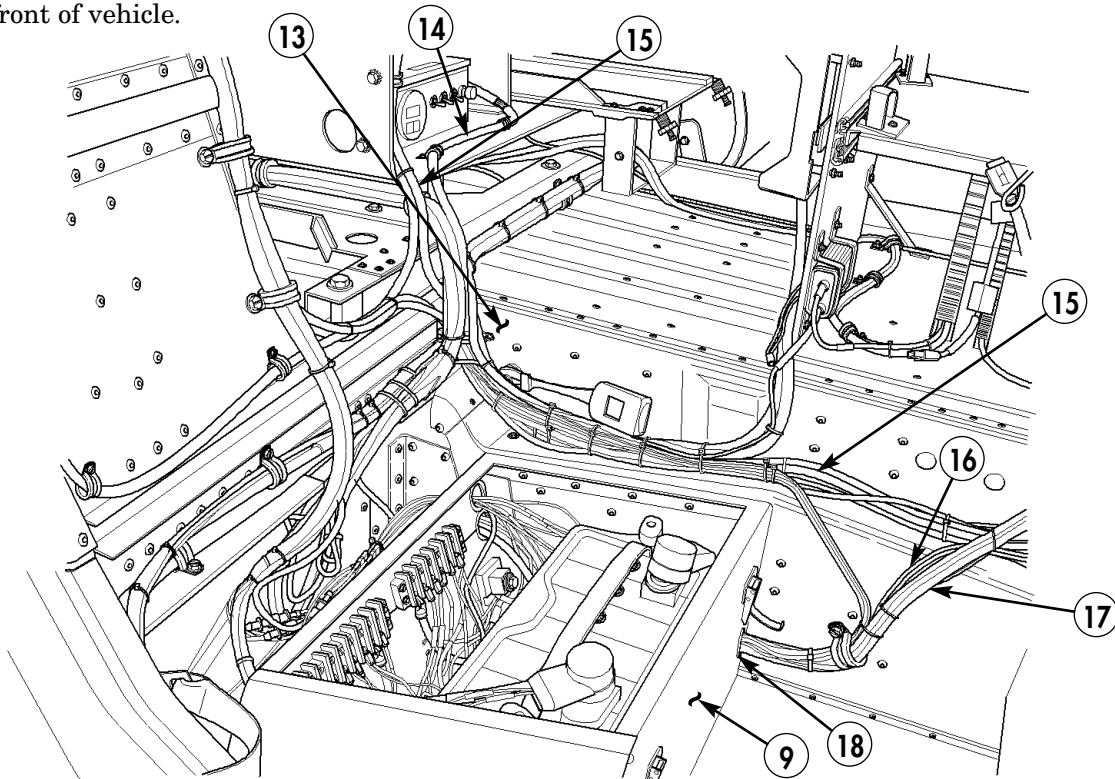

Figure 5-136.

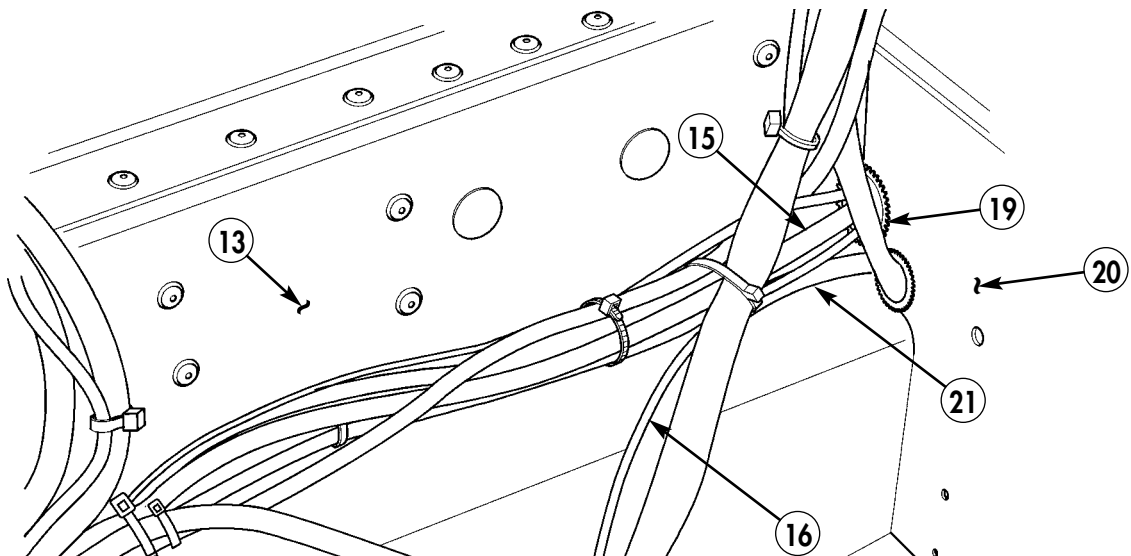

Figure 5-137.

47-13. Connect shunt cable (21) to battery (22).

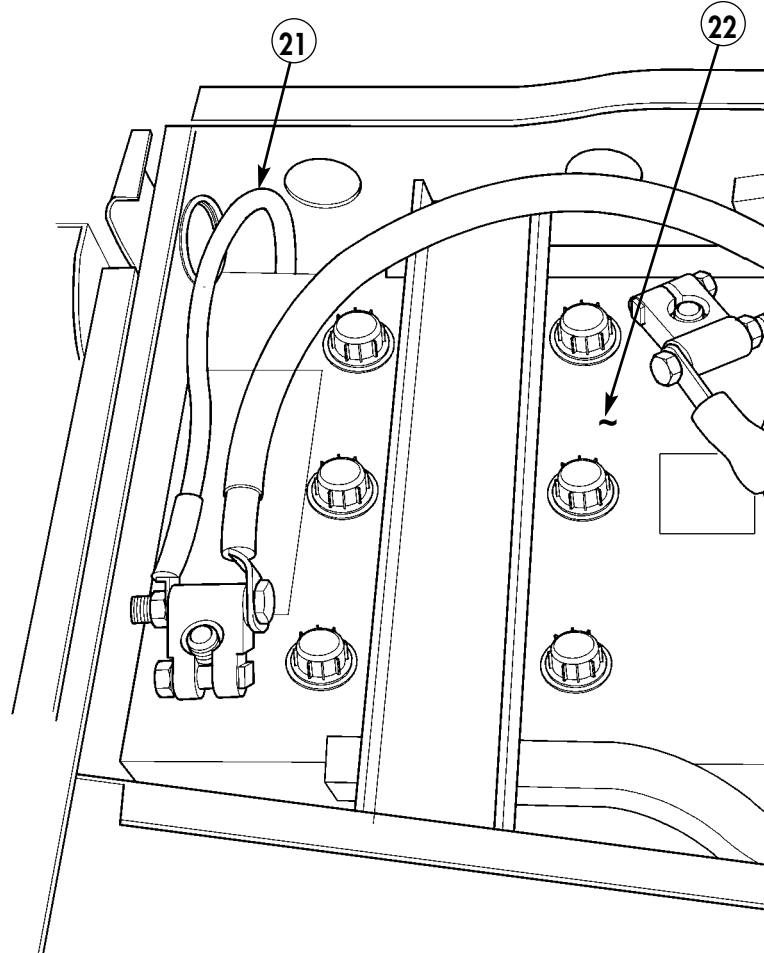
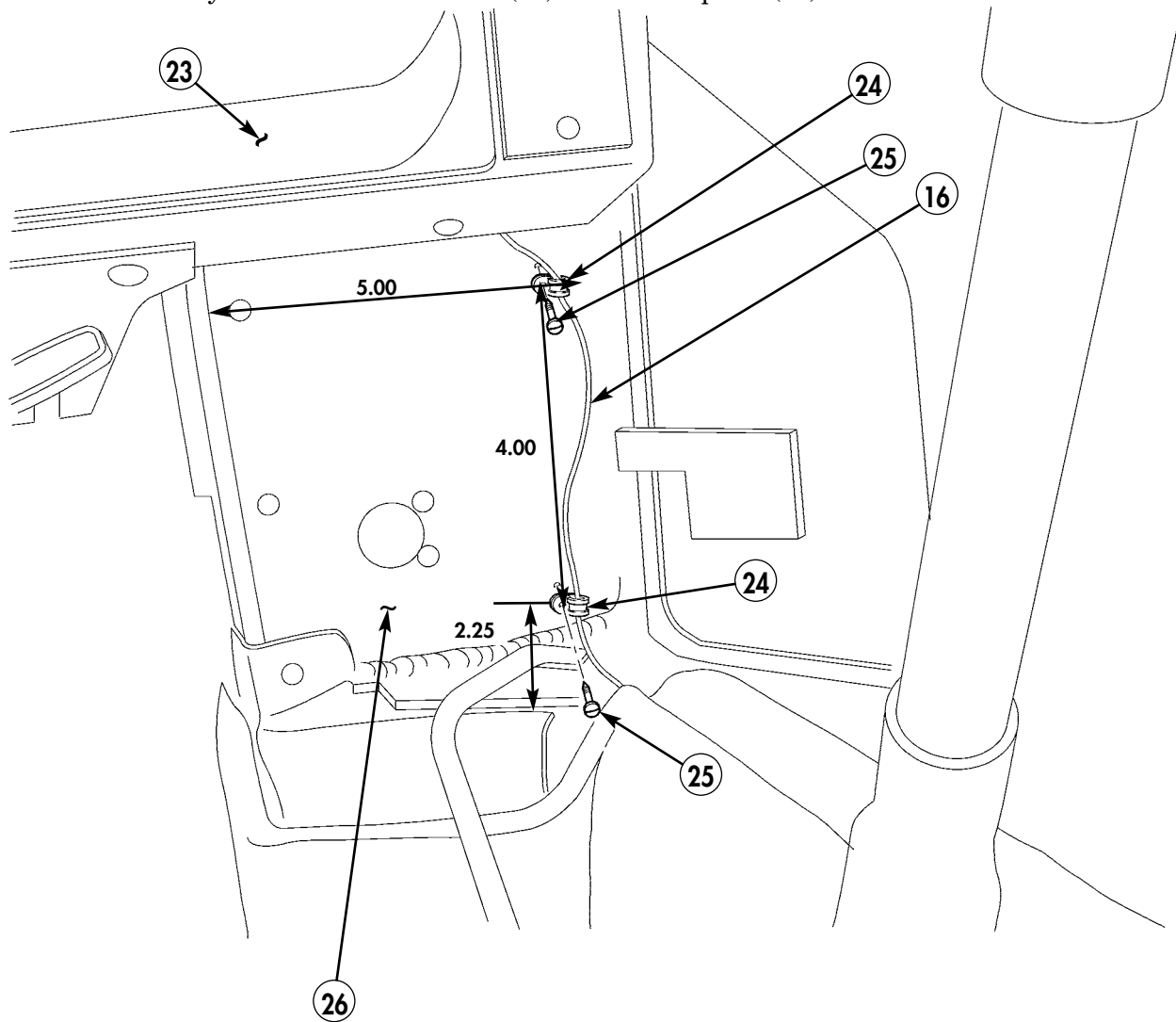

Figure 5-138.

- 47-14. Route battery alarm box control cable (16) from battery box and around integrated rack to left-side firewall (26).
- 47-15. Route battery alarm box control cable (16) up firewall (26).
- 47-16. Secure battery alarm box control cable (16) to firewall (26) with two clamps (24) and self-tapping screws (25).
- 47-17. Route battery alarm box control cable (16) under dash panel (23).



- 24. LOOP CLAMP – MS21333-71 – QTY. 2
- 25. SELF-TAPPING SCREW – 9421073 – QTY. 2

Figure 5-139.

47-18. Disconnect light switch (28) from harness (29).

47-19. Remove four bolts (27) and light switch (28) from dash panel (23).

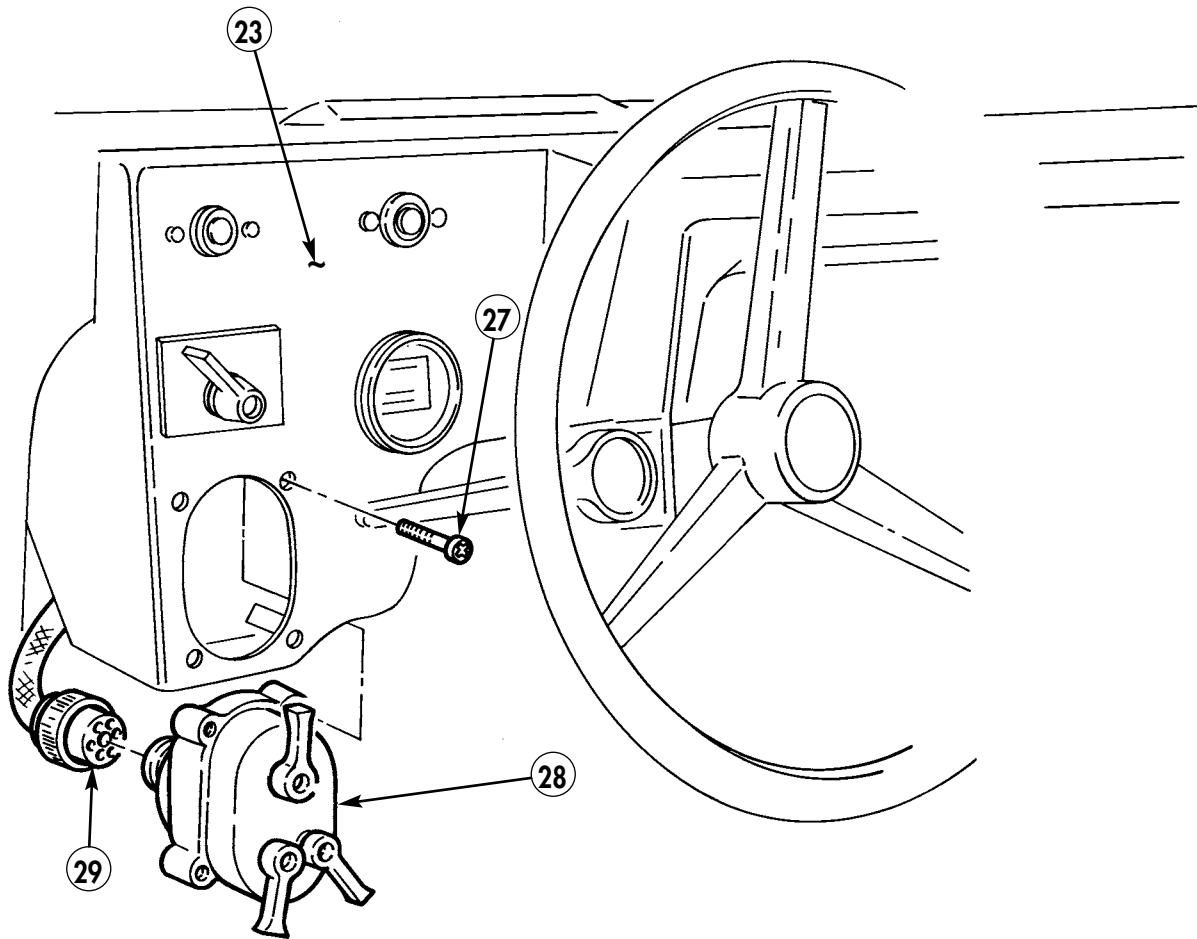

Figure 5-140.

- 47-20. Strip wire insulation from wire 29A (30).
- 47-21. Splice battery alarm box control cable (16) with wire 29A (30).
- 47-22. Cover splice with electrical tape (31).

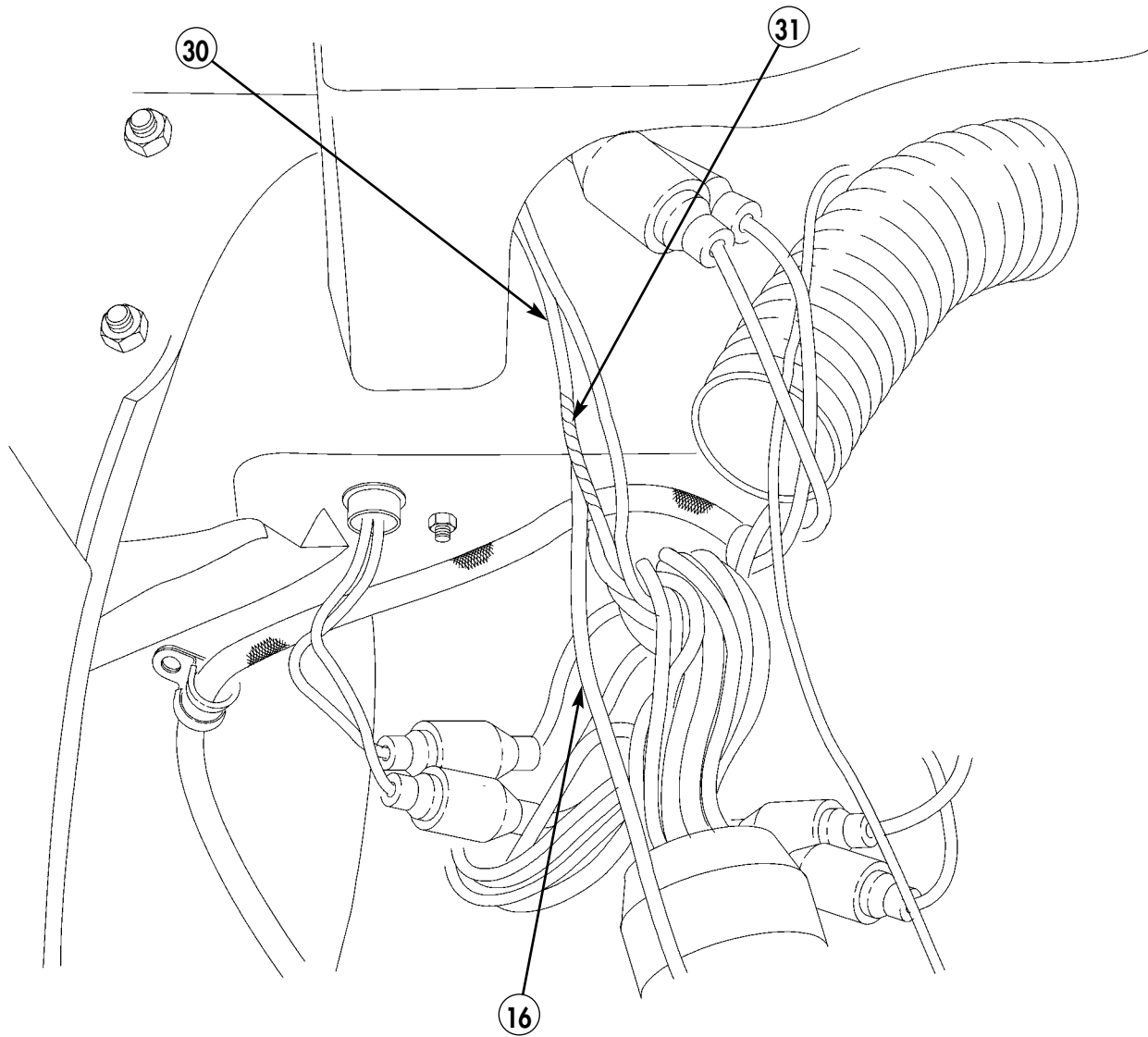

Figure 5-141.

47-23. Connect light switch (28) to harness (29).

47-24. Install light switch (28) in dash panel (23) with four bolts (27).

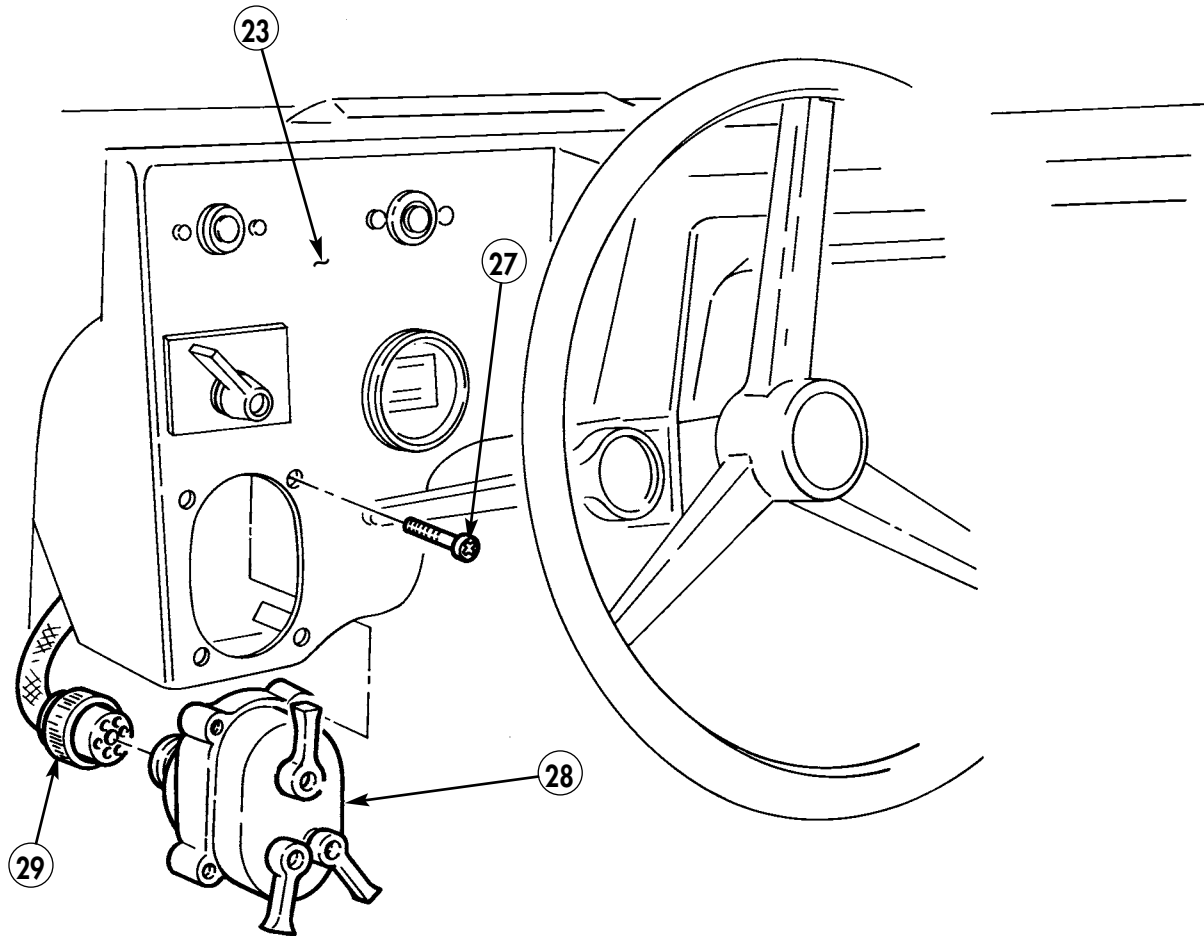
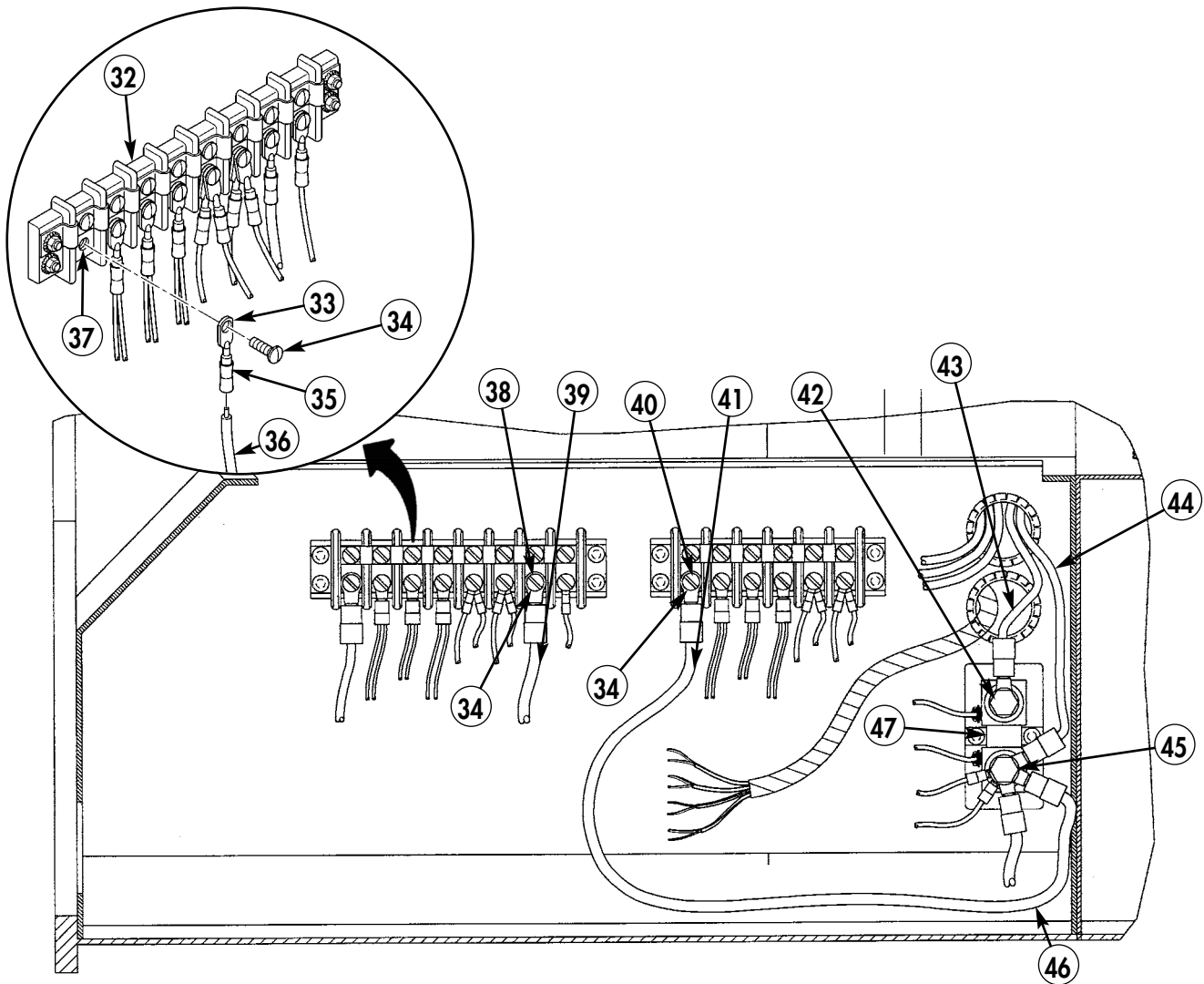

Figure 5-142.

- 47-25. Attach shrink tubing (35) and terminal lug (33) to master kill switch positive power cable (36). Secure cable (36) to terminal board hole (37) in terminal board (32) with existing screw (34).
- 47-26. Attach shrink tubing (35) and terminal lug (33) to Prosine inverter positive power cable (39). Secure cable (39) to terminal board hole (38) with existing screw (34).
- 47-27. Attach shrink tubing (35) and terminal lug (33) to shunt-to-terminal negative cable (41). Secure cable (41) to terminal board hole (40) with existing screw (34).
- 47-28. Attach shrink tubing (35) and terminal lug (33) to rear battery negative cable (43). Secure cable (43) to shunt (47) with existing screw (42).
- 47-29. Attach shrink tubing (35) and terminal lug (33) to Prosine inverter negative cable (44). Secure cable (44) to shunt (47) with existing screw (45).
- 47-30. Attach shrink tubing (35) and terminal lug (33) to shunt-to-terminal negative cable (41). Secure cable (41) to shunt (47) with existing screw (45).
- 47-31. Attach shrink tubing (35) and terminal lug (33) to shunt negative cable (46). Secure cable (46) to shunt (47) with existing screw (45).



- 33. TERMINAL LUG – CRS-DY-1406 – QTY. 7
- 35. SHRINK TUBE – MS23053/4-302-0 – QTY. A/R

Figure 5-143.

- 47-32. Attach shrink tubing (35) and terminal lug (48) to SINCGARS power cables (49) and (50). Secure cables (49) and (50) to terminal board hole (51) in terminal board (32) with existing screw (34).
- 47-33. Attach shrink tubing (35) and terminal lug (48) to lower EPLRS power cables (52) and (53). Secure cables (52) and (53) to terminal board hole (54) with existing screw (34).
- 47-34. Attach shrink tubing (35) and terminal lug (48) to upper EPLRS power cables (55) and (57). Secure cables (55) and (57) to terminal board hole (56) with existing screw (34).
- 47-35. Attach shrink tubing (35) and terminal lug (48) to SINCGARS negative cables (58) and (59). Secure cables (58) and (59) to terminal board hole (60) with existing screw (34).
- 47-36. Attach shrink tubing (35) and terminal lug (48) to lower EPLRS negative cables (61) and (63). Secure cables (61) and (63) to terminal board hole (62) with existing screw (34).
- 47-37. Attach shrink tubing (35) and terminal lug (48) to upper EPLRS negative cables (65) and (66). Secure cables (65) and (66) to terminal board hole (64) with existing screw (34).

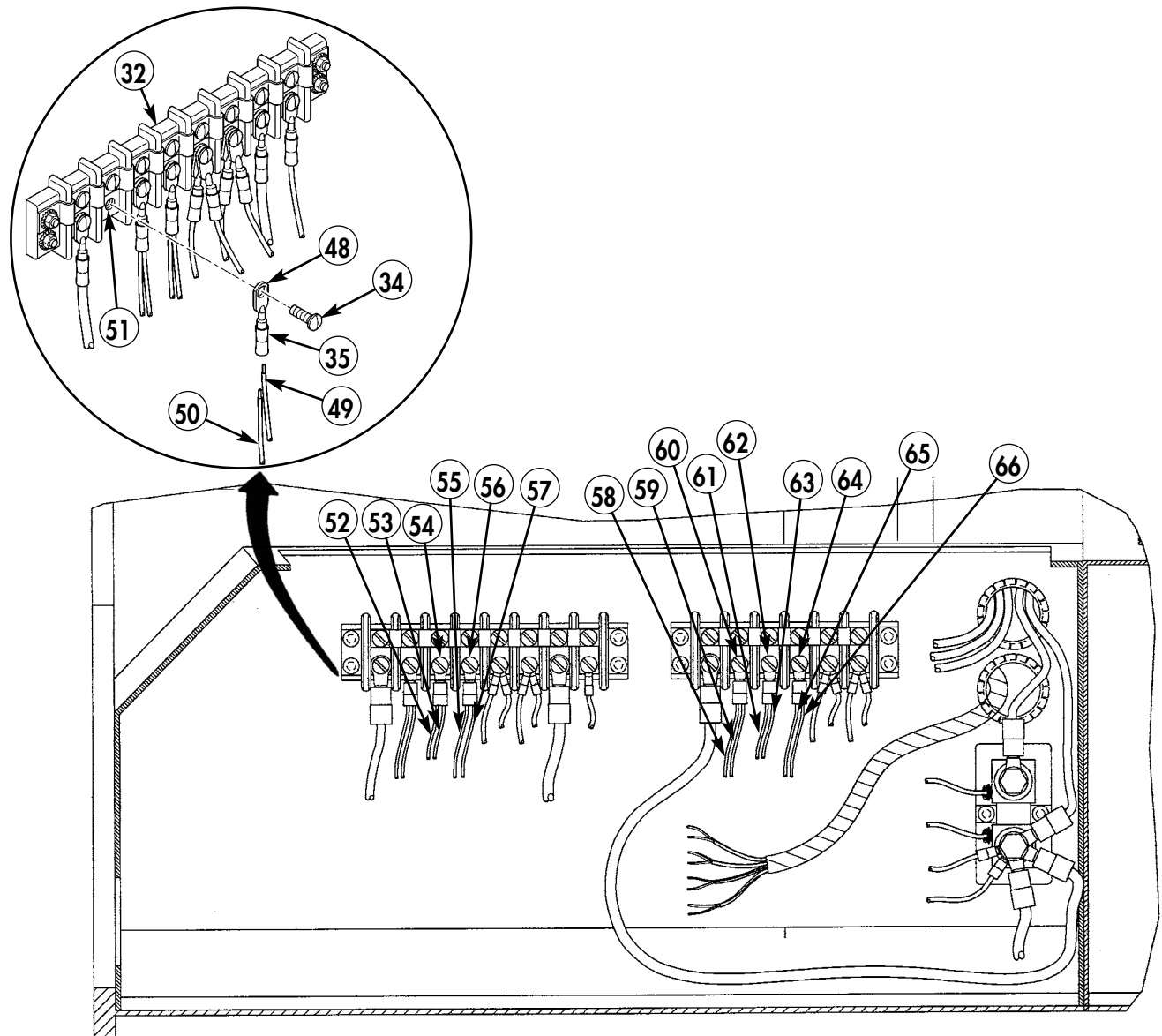

48. TERMINAL LUG – CRS-DY-1010 – QTY. 6

Figure 5-144.

- 47-38. Attach shrink tubing (35) and terminal lug (67) to PLGR power cable (69) and red wire (68) from battery alarm box cable. Secure cable (69) and wire (68) to terminal board hole (70) in terminal board (32) with existing screw (34).
- 47-39. Attach shrink tubing (35) and terminal lug (67) to blue wire (71) from battery alarm box cable and yellow wire (73) from battery alarm box cable. Secure wires (71) and (73) to terminal board hole (72) with existing screw (34).
- 47-40. Attach shrink tubing (35) and terminal lug (67) to DC-DC adapter power cable (75). Secure cable (75) to terminal board hole (74) with existing screw (34).
- 47-41. Attach shrink tubing (35) and terminal lug (67) to PLGR negative cable (76) and DC-DC adapter negative cable (77). Secure cables (76) and (77) to terminal board hole (78) with existing screw (34).
- 47-42. Attach shrink tubing (35) and terminal lug (67) to black wire (80) from battery alarm box cable and master kill switch box negative cable (81). Secure wire (80) and cable (81) to terminal board hole (79) with existing screw (34).

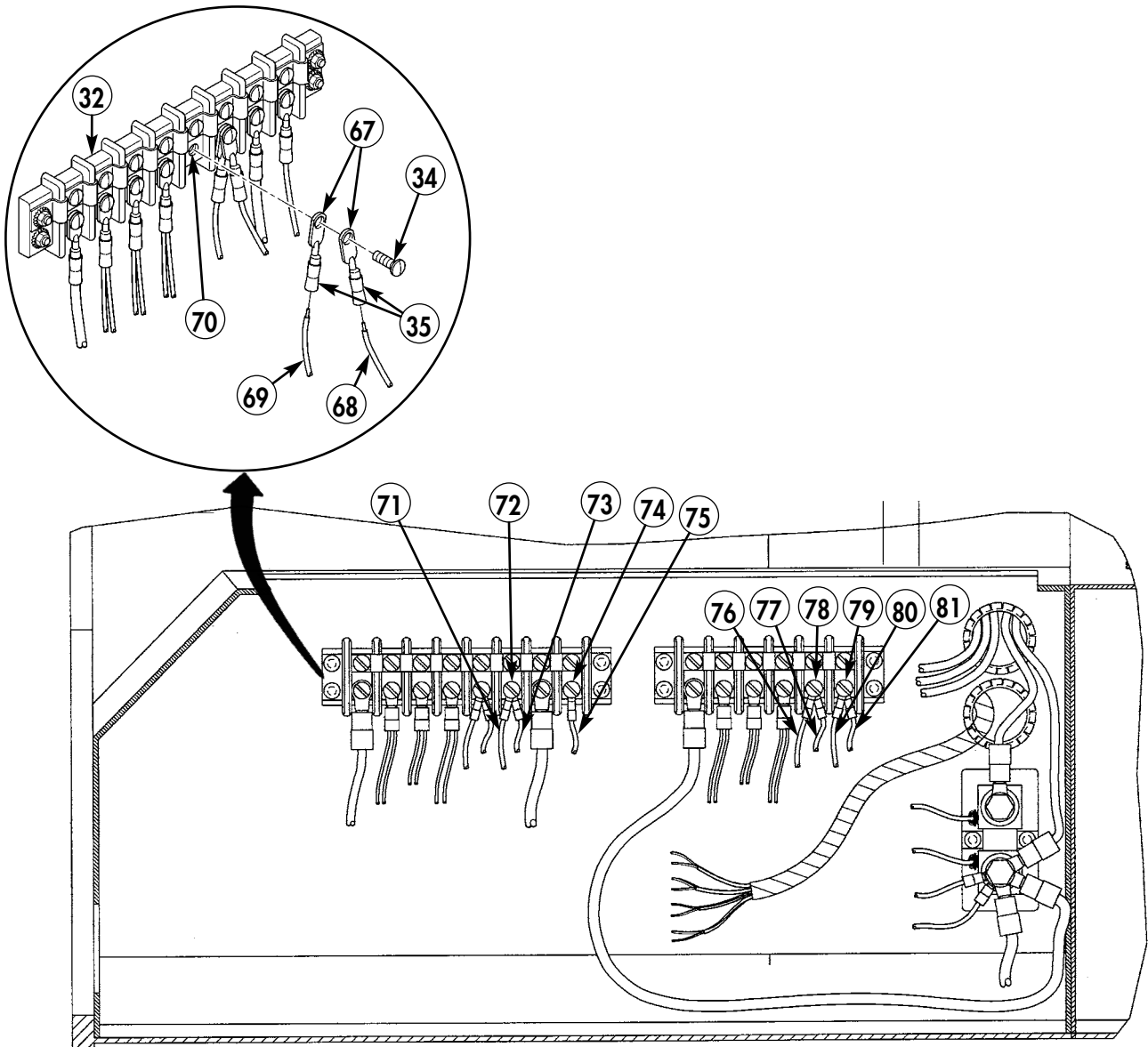

67. TERMINAL LUG – CRS-DY-1810 – QTY. 9

Figure 5-145.

- 47-43. Attach shrink tubing (35) and terminal lug (83) to orange wire (82) from battery alarm box cable. Secure wire (82) to shunt (47) with existing screw (84).
- 47-44. Attach shrink tubing (35) and terminal lug (83) to green wire (88) from battery alarm box cable. Secure wire (85) to shunt (47) with existing screw (84).
- 47-45. Attach shrink tubing (35) and terminal lug (83) to DC charger negative output cables (86) and (87). Secure cables (86) and (87) to shunt (47) with existing screw (45).
- 47-46. Attach shrink tubing (35) and terminal lug (83) to DC charger positive output cables (89) and (90). Secure cables (89) and (90) to negative terminal (96) on battery (95).
- 47-47. Attach shrink tubing (35) and terminal lug (83) to DC charger negative output cables (91) and (93). Secure cables (91) and (93) to negative terminal (96) on battery (95).
- 47-48. Attach shrink tubing (35) and terminal lug (83) to DC charger positive output cables (92) and (94). Secure cables (92) and (94) to positive terminal (97) on battery (95).

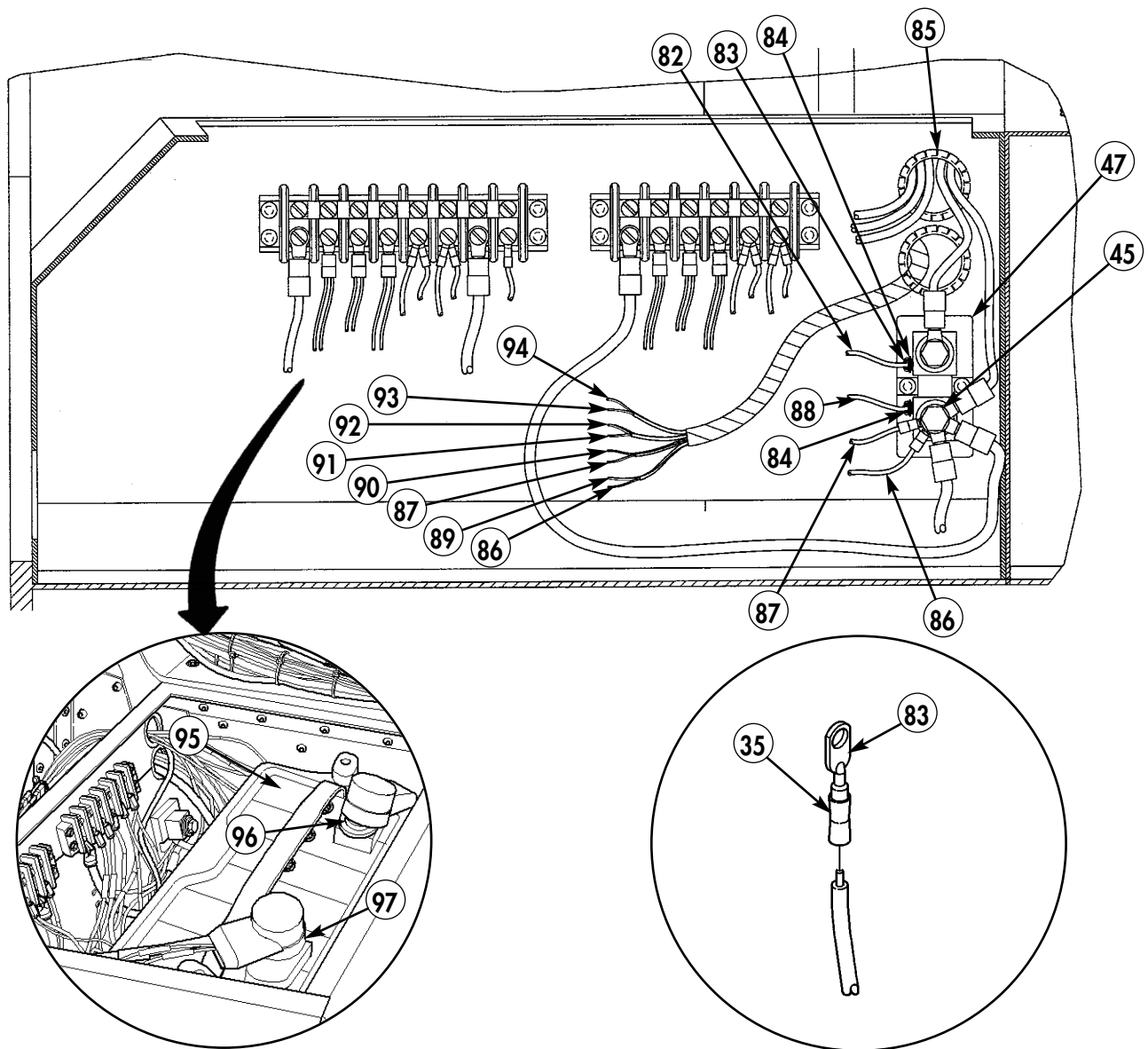

83. TERMINAL LUG – CRS-DY-1410 – QTY. 10

Figure 5-146.

SECTION XLVIII. WINDSHIELD ARMOR MODIFICATION

NOTE

Perform following steps for vehicles with bolt-on armor installed.

- 48-1. Remove four capscrews (5) and left capping ring (4) from left side of windshield frame (1).
- 48-2. Remove four capscrews (5) and right capping ring (6) from right side of windshield frame (1).
- 48-3. Remove five capscrews (3) and upper capping ring (2) from windshield frame (1).

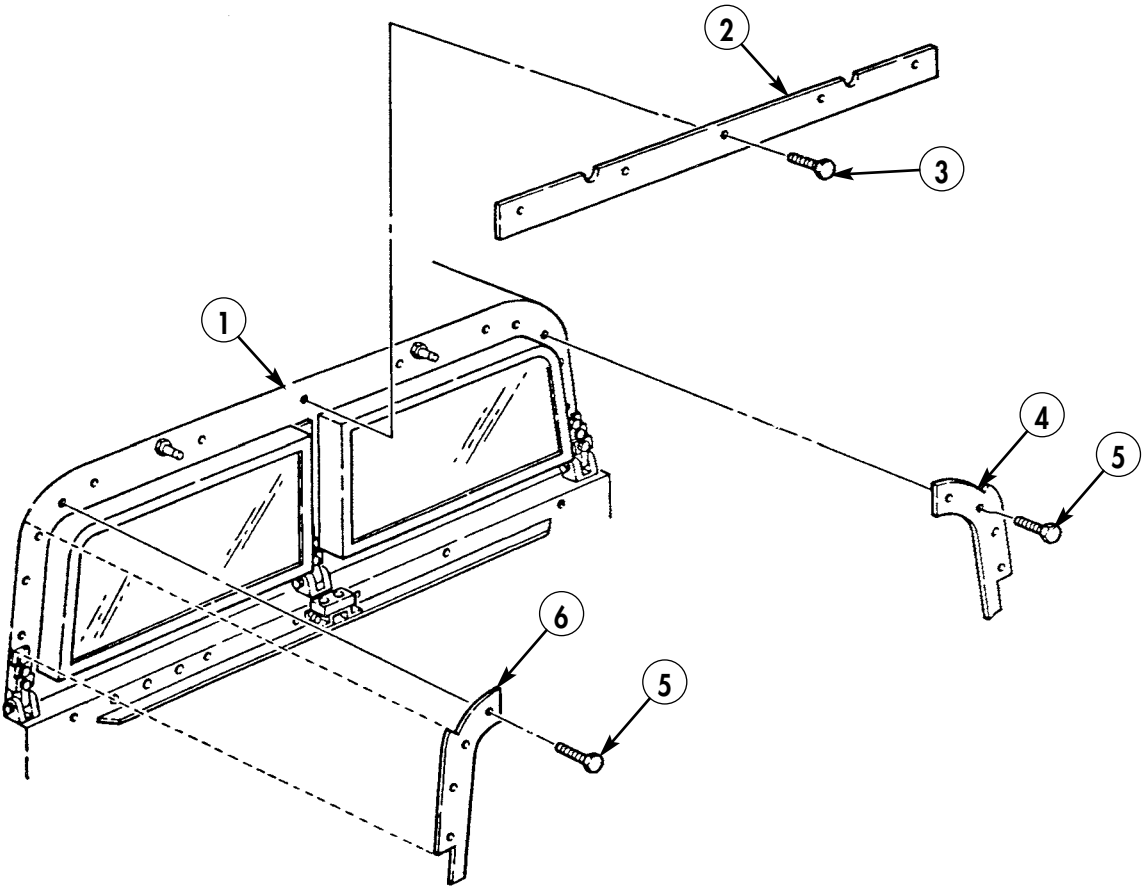

Figure 5-147.

NOTE

Left side shown; right side opposite.

48-4. Locate, mark, and remove section of armor on left capping ring (4). Repeat for right side.

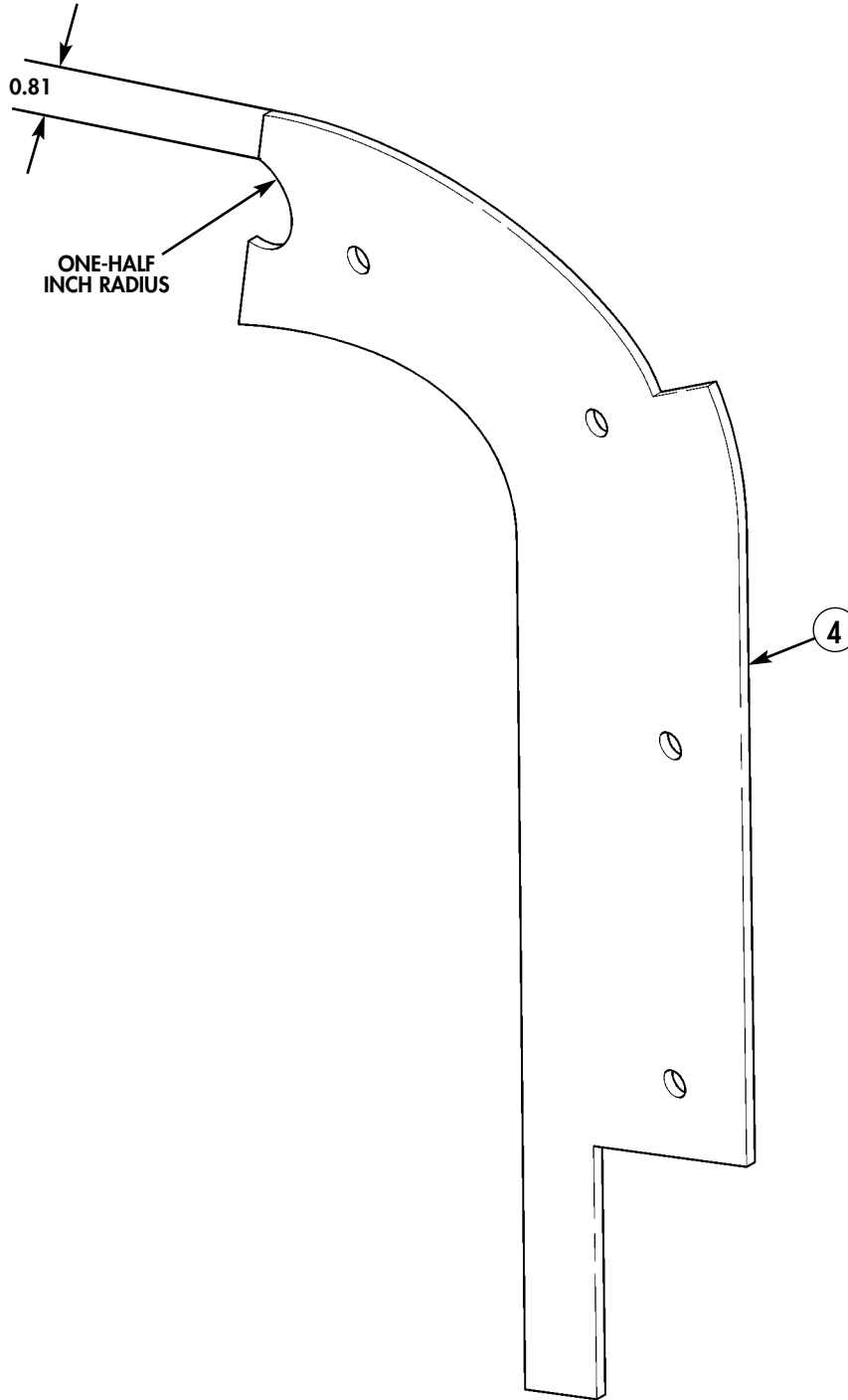

Figure 5-148.

NOTE

Right side shown; left side opposite.

- 48-5. Locate, mark, and remove sections of armor on upper capping ring (2).
- 48-6. Spot paint all exposed metal surfaces. (Refer to TM 43-0139.)

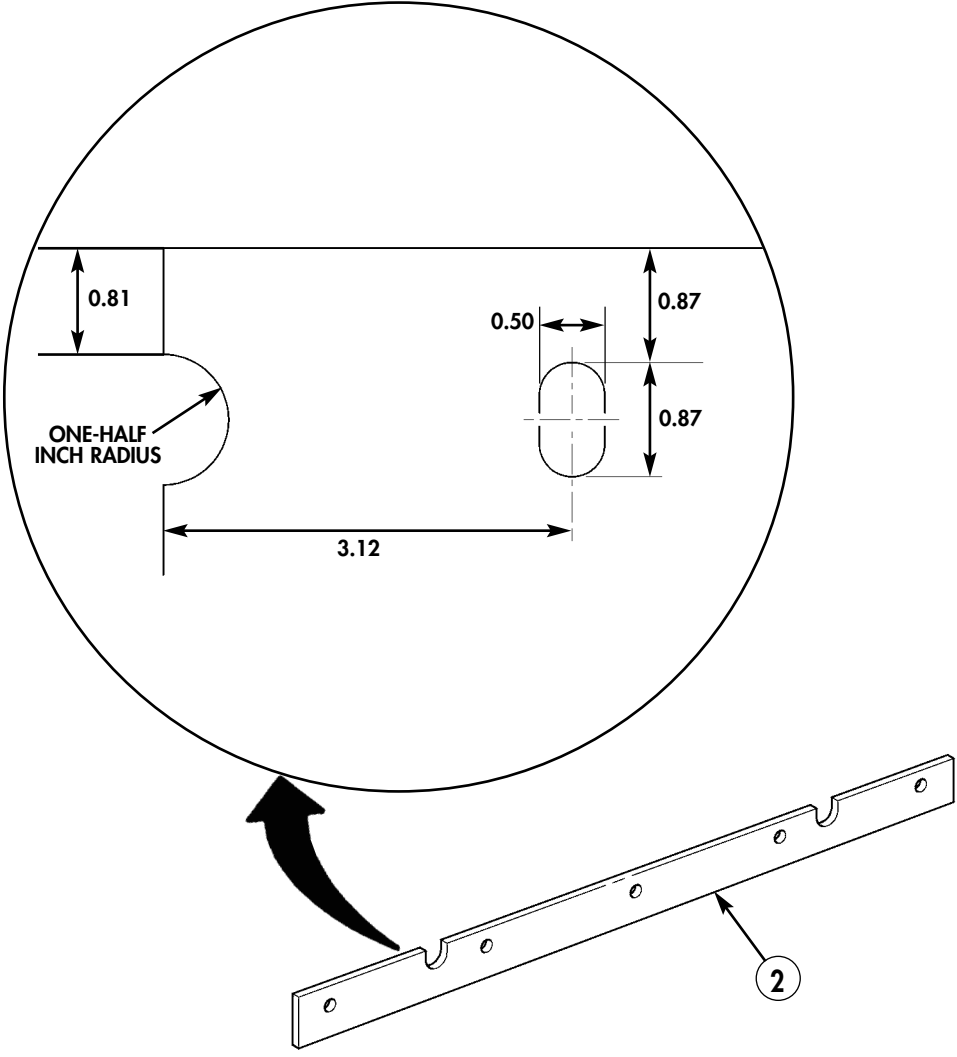

Figure 5-149.

Section XLIX. ARMOR AND ANTENNA INSTALLATION (WITH BOLT-ON ARMOR)

NOTE

Perform following steps for vehicles with bolt-on armor installed.

- 49-1. Remove two plugs (2) from right side of windshield frame (4).
- 49-2. Install wellnuts (1) and (3) in right side of windshield frame.

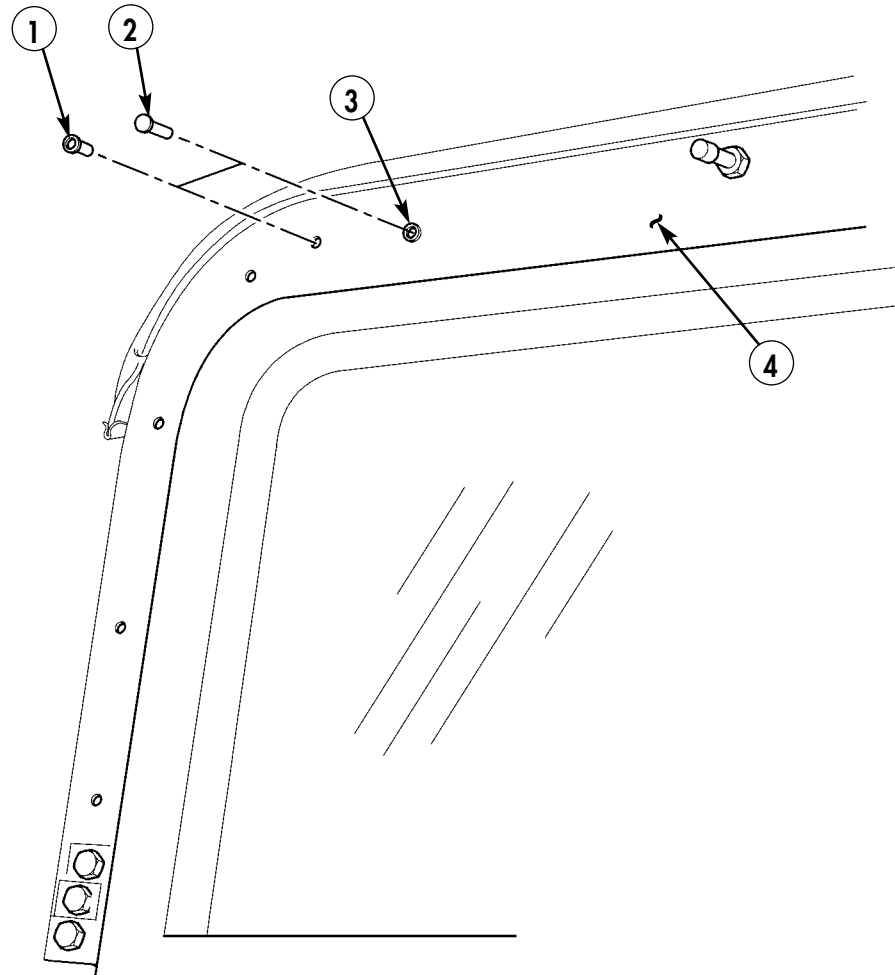

- 1. WELLNUT - 12339397-6 - QTY. 1
- 3. WELLNUT - 12339397-3 - QTY. 1

Figure 5-150.

NOTE

It may be necessary to drill pilot hole prior to drilling 0.562-in. diameter hole.

49-3. Locate, mark, and drill one 0.562-in. diameter hole (5) on right side of A-pillar (6).

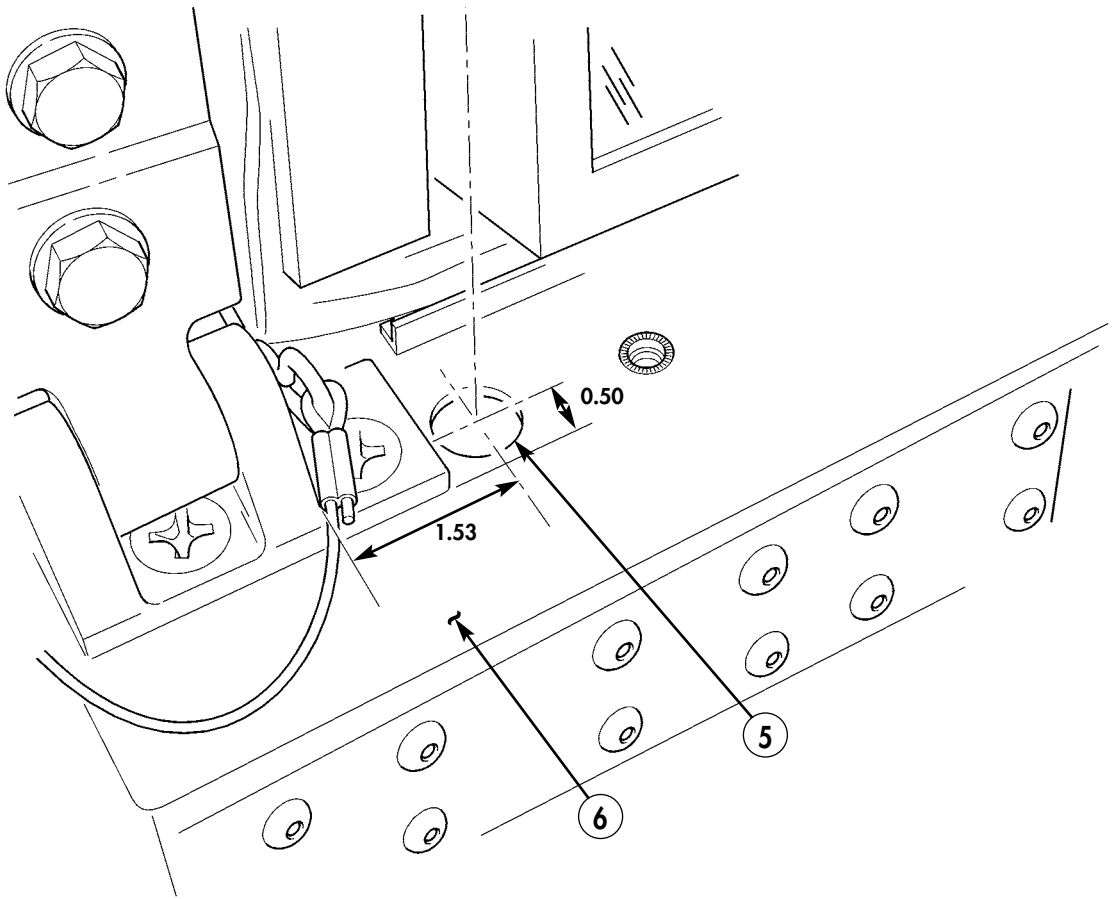

Figure 5-151.

- 49-4. Install modified upper capping ring (7) on windshield frame (4) with five existing capscrews (8).
- 49-5. Install modified right capping ring (11) on right side of windshield frame (4) with four existing capscrews (10).
- 49-6. Install modified left capping ring (9) on left side of windshield frame (4) with four existing capscrews (10).

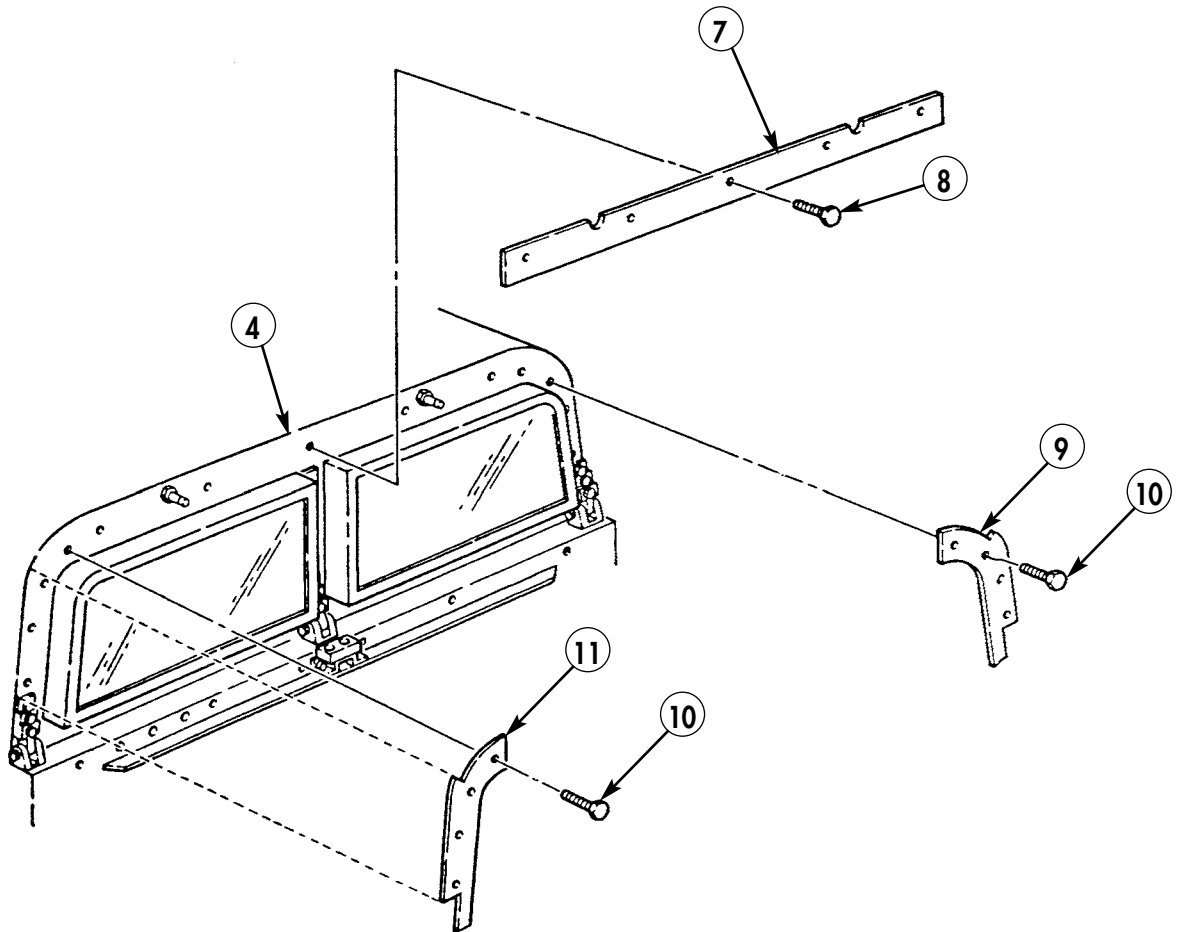
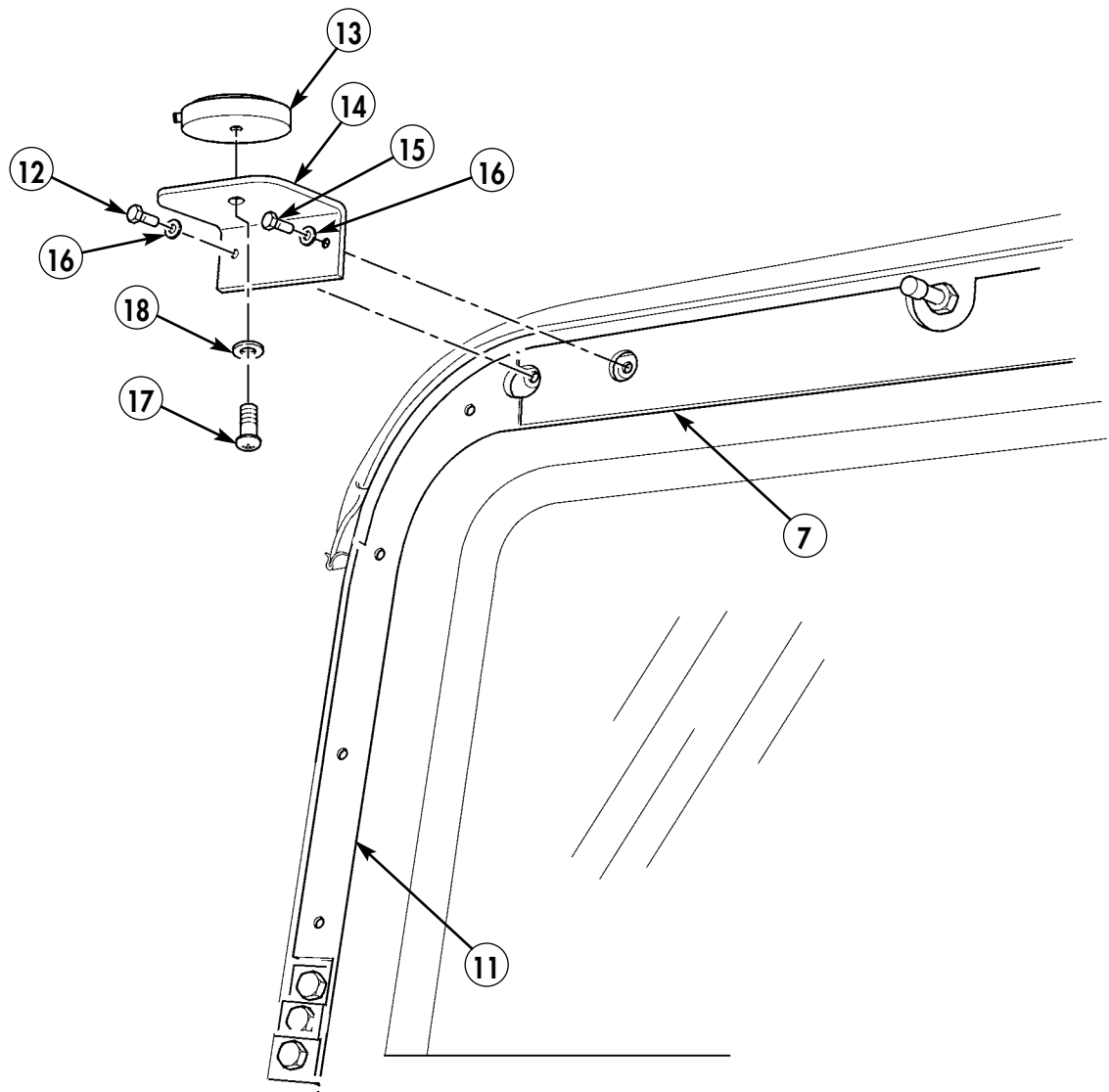

Figure 5-152.

- 49-7.** Install antenna (13) on support (14) with lockwasher (18) and capscrew (17).
- 49-8.** Install support (14) on right capping ring (11) and upper capping ring (7) with two capscrews (12) and (15) and two washers (16).



12. CAPSCREW - B1821BH025C125N - QTY. 1
 13. PLGR ANTENNA - AT575-030 - QTY. 1
 14. PLGR ANTENNA MOUNT BRACKET - 12480578 - QTY. 1
 15. CAPSCREW - B1821BH025C175N - QTY. 1
 16. WASHER - 2436161 - QTY. 2
 17. CAPSCREW - MS35207-261 - QTY. 1
 18. LOCKWASHER - MS35338-43 - QTY. 1

Figure 5-153.

Section L. ANTENNA CABLE INSTALLATION

NOTE

Perform following steps for vehicles with bolt-on armor installed.

- 50-1. Route antenna cable (1) through hole (5) and connect antenna cable (1) to antenna (2).
- 50-2. Remove self-tapping screw (4) from right capping ring (3).
- 50-3. Secure antenna cable (1) to right capping ring (3) with clamp (6) and existing self-tapping screw (4).

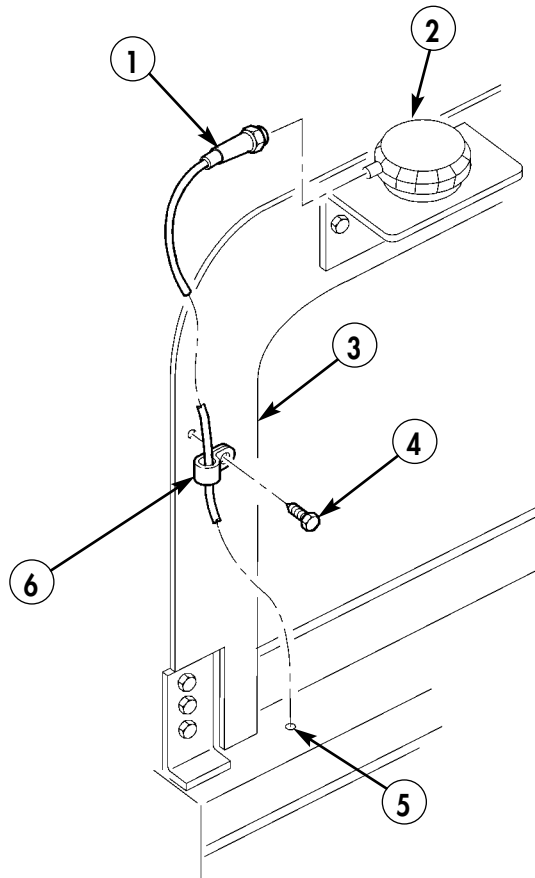

- 1. ANTENNA CABLE – A32551281W23 – QTY. 1
- 6. CLAMP – MS21333-96 – QTY. 1

Figure 5-154.

- 50-4. Split grommet (8) and install on antenna cable (1).
- 50-5. Wrap electrical tape (7) around antenna cable (1).
- 50-6. Install antenna cable (1) with electrical tape (7) in grommet (8).

NOTE

Apply sealing compound on grommet.

- 50-7. Install grommet (8) in hole (5) on A-pillar (9).

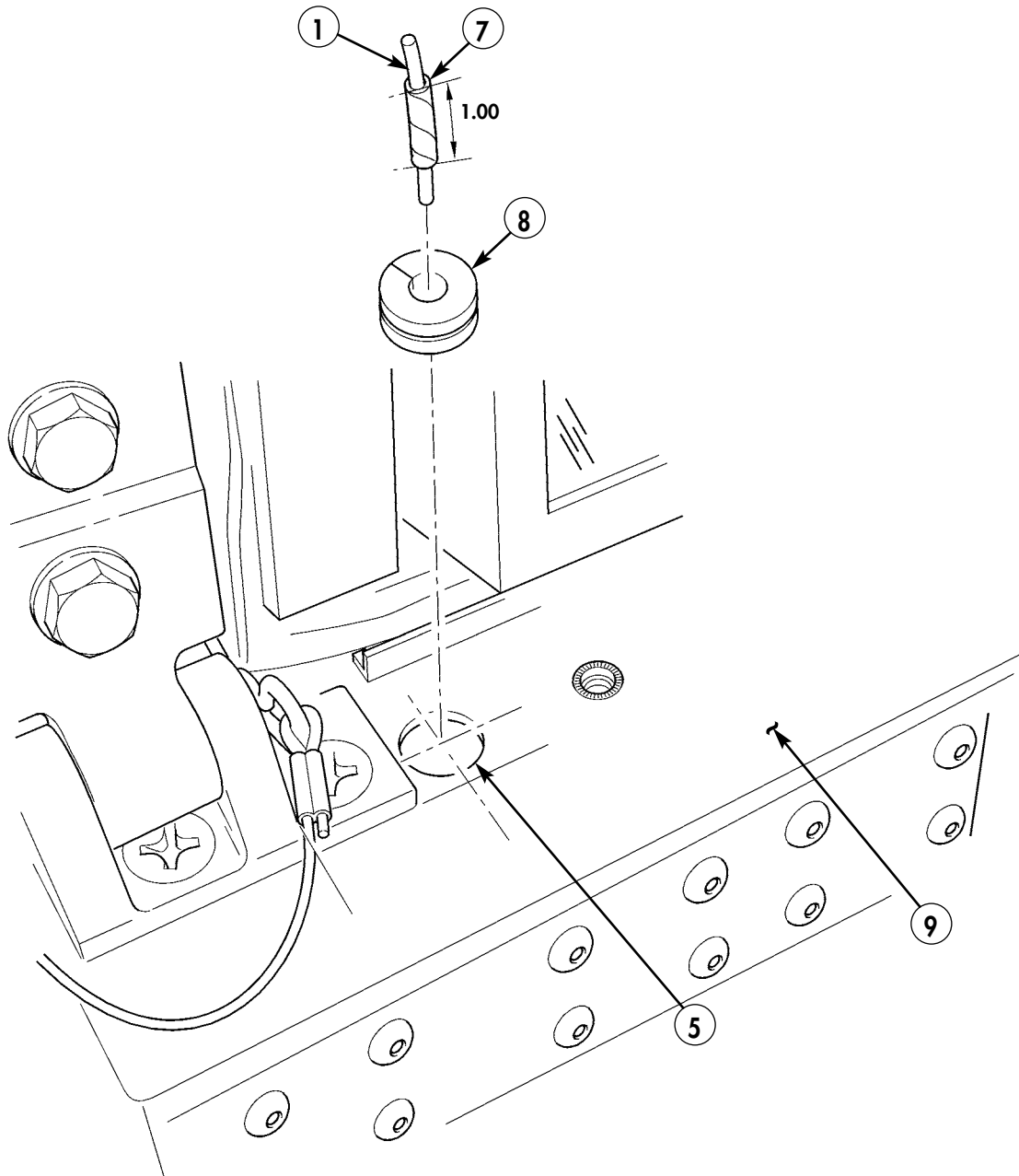

- 7. ELECTRICAL TAPE – HH-I-595 – QTY. A/R
- 8. GROMMET – MS35489-31 – QTY. 1

Figure 5-155.

- 50-8. Route antenna cable (1) behind heater shield (12) to installation mount (13).
- 50-9. Locate, mark, and drill one 0.147-in. diameter hole (16) in plenum (9).
- 50-10. Secure antenna cable (1) to plenum (9) with clamp (11) and self-tapping screw (10).
- 50-11. Secure excess antenna cable (1) behind installation mount (13) on integrated radio rack (15) with tiedown strap (14).

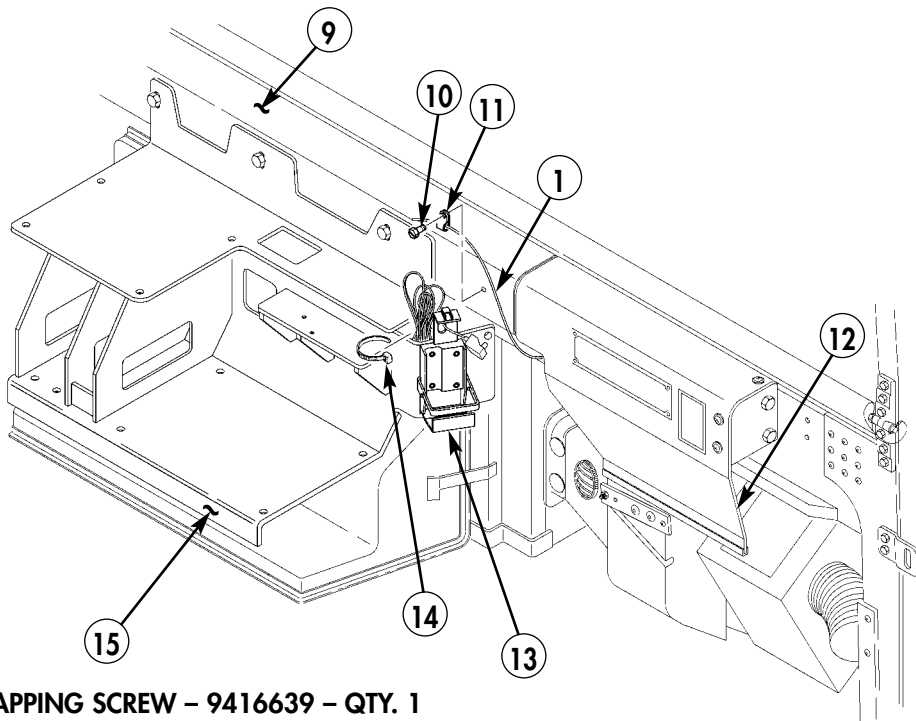

- 10. SELF-TAPPING SCREW – 9416639 – QTY. 1
- 11. CLAMP – MS21333-67 – QTY. 1
- 14. TIEDOWN STRAP – MS3367-1-0 – QTY. 1

Figure 5-156.

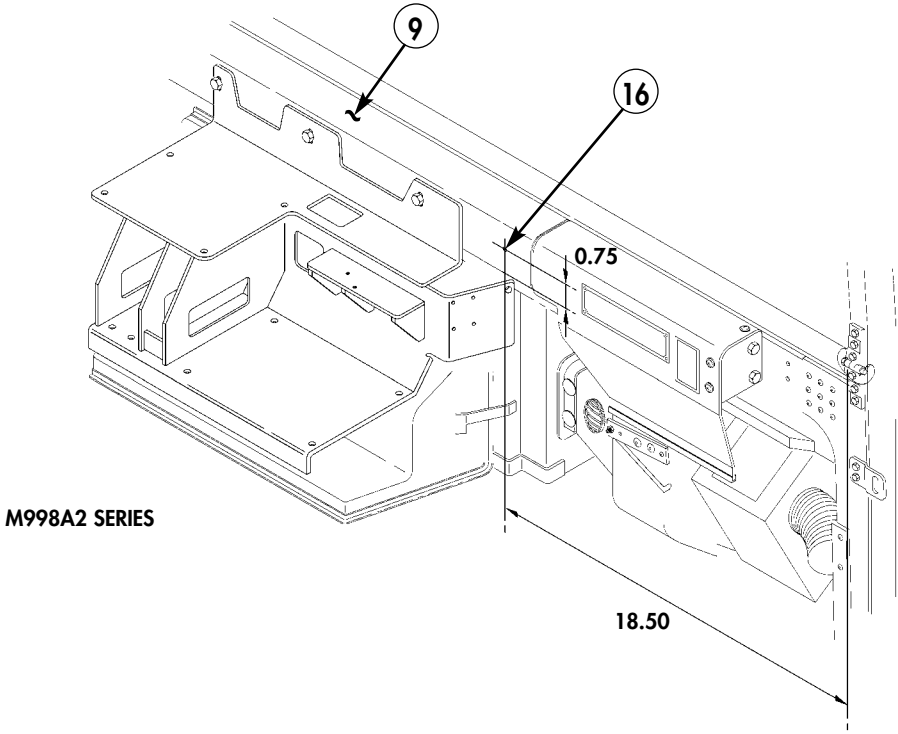
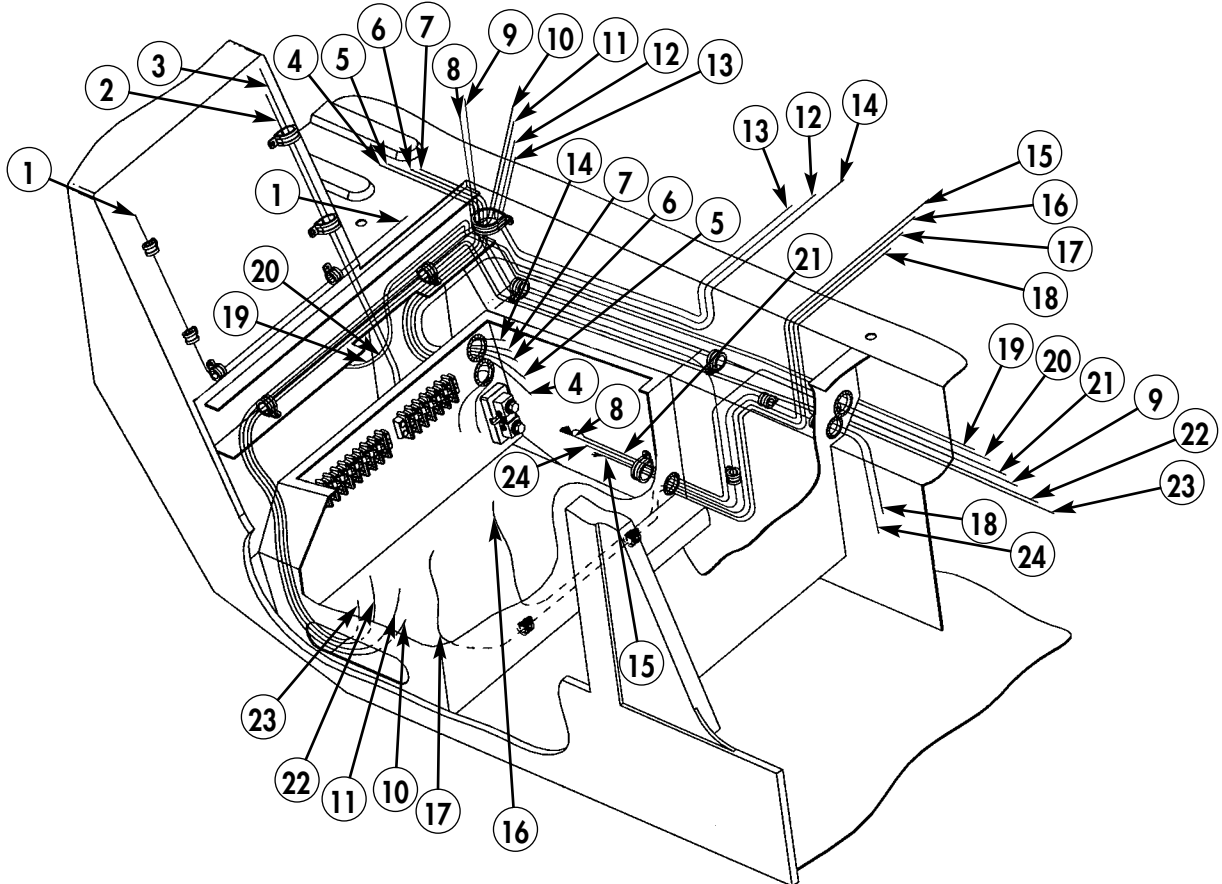

Figure 5-157.

CABLE SCHEMATIC APPENDIX

1. RIGHT-SIDE EPLRS ANTENNA CABLE FROM RIGHT-SIDE EPLRS ANTENNA TO LOWER EPLRS RADIO.
2. DC CHARGER CABLE FROM DC CHARGER TO BATTERY.
3. DC CHARGER CABLE FROM DC CHARGER TO SHUNT.
4. REAR BATTERY NEGATIVE CABLE FROM REAR BATTERY TO SHUNT.
5. REAR BATTERY POSITIVE CABLE FROM REAR BATTERY TO BATTERY NEGATIVE TERMINAL.
6. INVERTER POSITIVE CABLE FROM INVERTER TO TERMINAL STRIP ONE TERMINAL SEVEN.
7. INVERTER NEGATIVE CABLE FROM INVERTER TO SHUNT.
8. BATTERY ALARM BOX CABLE FROM BATTERY ALARM BOX TO BATTERY BOX.
9. INC-EPUU CABLE FROM LOWER EPLRS RADIO TO SINGGARS RADIO ADAPTER.
10. EPLRS POWER CABLE FROM LOWER EPLRS RADIO TO TERMINAL STRIPS ONE AND TWO.
11. EPLRS POWER CABLE FROM UPPER EPLRS RADIO TO TERMINAL STRIPS ONE AND TWO.
12. EPLRS URO EXTENSION CABLE FROM LOWER EPLRS RADIO TO URO BRACKET.
13. EPLRS URO EXTENSION CABLE FROM UPPER EPLRS RADIO TO URO BRACKET.
14. DC-DC ADAPTER CABLE FROM DC-DC ADAPTER TO TERMINAL STRIPS ONE AND TWO.
15. MASTER KILL SWITCH BOX CABLE FROM MASTER KILL SWITCH BOX TO BATTERY BOX.
16. MASTER KILL SWITCH BOX CABLE FROM MASTER KILL SWITCH BOX TO BATTERY POSITIVE TERMINAL.
17. MASTER KILL SWITCH BOX CABLE FROM MASTER KILL SWITCH BOX TO TERMINAL STRIP ONE TERMINAL ONE.
18. MASTER KILL SWITCH BOX CABLE FROM MASTER KILL SWITCH BOX TO VEHICLE BATTERY POSITIVE TERMINAL.
19. SINGGARS ANTENNA CABLE FROM SINGGARS RADIO TO SINGGARS CURBSIDE ANTENNA.
20. SINGGARS ANTENNA CABLE FROM SINGGARS RADIO TO SINGGARS ROADSIDE ANTENNA.
21. BATTERY ALARM BOX CABLE FROM BATTERY BOX TO IGNITION SWITCH.
22. PLGR POWER CABLE FROM PLGR TO TERMINAL STRIPS ONE AND TWO.
23. SINGGARS POWER CABLE FROM SINGGARS MOUNT TO TERMINAL STRIPS ONE AND TWO.
24. SHUNT NEGATIVE CABLE FROM SHUNT TO VEHICLE BATTERY NEGATIVE TERMINAL.



By Order of the Secretary of the Army:

PETER J. SCHOOMAKER
General, United States Army
Chief of Staff

Official:



SANDRA R. RILEY
Administrative Assistant to the
Secretary of the Army
0533602

Distribution:

To be distributed in accordance with the Initial Distribution Number (IDN) 344840 requirements for TB 9-2320-280-35-12.

RECOMMENDED CHANGES TO PUBLICATIONS AND BLANK FORMS For use of this form, see AR 25-30; the proponent agency is ODISC4.	Use Part II (reverse) for Repair Parts and Special Tools Lists (RPSTL) and Supply Catalogs/Supply Manuals (SC/SM).	DATE: <p style="text-align: right;">28 Feb. 2006</p>
---	--	--

TO: <i>(Forward to proponent of publication or form) (include ZIP code)</i> AMSTA-LC-LPIT/Tech Pubs, TACOM-RI 1 Rock Island Arsenal Rock Island, IL 61299-7630	FROM: <i>(Activity and location) (include ZIP code)</i> <p style="text-align: center;">Co. B, 1st BN, 2nd Brigade Ft. Hood, TX 76445</p>
--	--

PART I - ALL PUBLICATIONS (EXCEPT RPSTL AND SC/SM) AND BLANK FORMS

PUBLICATION/FORM NUMBER <p style="text-align: center;">TB 9-2320-280-35-12</p>	DATE <p style="text-align: center;">28 FEB. 2006</p>	TITLE <p style="text-align: center;">TECHNICAL BULLETIN INSTALLATION INSTRUCTIONS</p>
---	---	---

ITEM NO.	PAGE NO.	PARA-GRAPH	LINE NO.*	FIGURE NO.	TABLE NO.	RECOMMENDED CHANGES AND REASON <i>(Provide exact wording of recommended changes, if possible)</i>
----------	----------	------------	-----------	------------	-----------	--

10	5-45		26-1	5-63		<p>Grommet should be installed on antenna bracket instead of the fiberglass body.</p>
----	------	--	------	------	--	---

SAMPLE

**Reference to line numbers within the paragraph or subparagraph.*

TYPED NAME, GRADE, OR TITLE <p style="text-align: center;">Pat Smith</p>	TELEPHONE EXCHANGE/AUTOVON, PLUS EXTENSION <p style="text-align: center;">AV272-4162</p>	SIGNATURE <p style="text-align: center;"><i>Pat Smith</i></p>
--	--	--

TO: <i>(Forward direct to addressee listed in publication)</i> AMSTA-LC-LPIT/Tech Pubs, TACOM-RI 1 Rock Island Arsenal Rock Island, IL 61299-7630	FROM: <i>(Activity and location) (include ZIP code)</i>	DATE: 28 Feb. 2006
--	---	------------------------------

PART II - REPAIR PARTS AND SPECIAL TOOLS LISTS AND SUPPLY CATALOGS/SUPPLY MANUALS

PUBLICATION/FORM NUMBER TB 9-2320-280-35-12	DATE 28 FEB. 2006	TITLE TECHNICAL BULLETIN INSTALLATION INSTRUCTIONS
---	-----------------------------	--

PAGE NO.	COLM NO.	LINE NO.	NATIONAL STOCK NUMBER	REFERENCE NO.	FIGURE NO.	ITEM NO.	TOTAL NO. OF MAJOR ITEMS SUPPORTED	RECOMMENDED ACTION
----------	----------	----------	-----------------------	---------------	------------	----------	------------------------------------	--------------------

SAMPLE

PART III - REMARKS *(Any general remarks or recommendations, or suggestions for improvement of publications and blank forms. Additional blank sheets may be used if more space is needed.)*

TYPED NAME, GRADE, OR TITLE			TELEPHONE EXCHANGE/AUTOVON, PLUS EXTENSION			SIGNATURE		
-----------------------------	--	--	--	--	--	-----------	--	--

RECOMMENDED CHANGES TO PUBLICATIONS AND BLANK FORMS For use of this form, see AR 25-30; the proponent agency is ODISC4.				Use Part II (reverse) for Repair Parts and Special Tools Lists (RPSTL) and Supply Catalogs/Supply Manuals (SC/SM).		DATE:
TO: <i>(Forward to proponent of publication or form) (include ZIP code)</i> AMSTA-LC-LPIT/Tech Pubs, TACOM-RI 1 Rock Island Arsenal Rock Island, IL 61299-7630				FROM: <i>(Activity and location) (include ZIP code)</i>		
PART I - ALL PUBLICATIONS (EXCEPT RPSTL AND SC/SM) AND BLANK FORMS						
PUBLICATION/FORM NUMBER TB 9-2320-280-35-12			DATE 28 FEB. 2006		TITLE TECHNICAL BULLETIN INSTALLATION INSTRUCTIONS	
ITEM NO.	PAGE NO.	PARA-GRAPH	LINE NO.*	FIGURE NO.	TABLE NO.	RECOMMENDED CHANGES AND REASON <i>(Provide exact wording of recommended changes, if possible)</i>
<i>*Reference to line numbers within the paragraph or subparagraph.</i>						
TYPED NAME, GRADE, OR TITLE				TELEPHONE EXCHANGE/AUTOVON, PLUS EXTENSION		SIGNATURE

TO: <i>(Forward direct to addressee listed in publication)</i> AMSTA-LC-LPIT/Tech Pubs, TACOM-RI 1 Rock Island Arsenal Rock Island, IL 61299-7630	FROM: <i>(Activity and location) (include ZIP code)</i>	DATE:
---	--	--------------

PART II - REPAIR PARTS AND SPECIAL TOOLS LISTS AND SUPPLY CATALOGS/SUPPLY MANUALS

PUBLICATION/FORM NUMBER TB 9-2320-280-35-12	DATE 28 FEB. 2006	TITLE TECHNICAL BULLETIN INSTALLATION INSTRUCTIONS
---	-----------------------------	---

PAGE NO.	COLM NO.	LINE NO.	NATIONAL STOCK NUMBER	REFERENCE NO.	FIGURE NO.	ITEM NO.	TOTAL NO. OF MAJOR ITEMS SUPPORTED	RECOMMENDED ACTION

PART III - REMARKS *(Any general remarks or recommendations, or suggestions for improvement of publications and blank forms. Additional blank sheets may be used if more space is needed.)*

--

TYPED NAME, GRADE, OR TITLE	TELEPHONE EXCHANGE/AUTOVON, PLUS EXTENSION	SIGNATURE

RECOMMENDED CHANGES TO PUBLICATIONS AND BLANK FORMS For use of this form, see AR 25-30; the proponent agency is ODISC4.				Use Part II (reverse) for Repair Parts and Special Tools Lists (RPSTL) and Supply Catalogs/Supply Manuals (SC/SM).		DATE:
TO: <i>(Forward to proponent of publication or form) (include ZIP code)</i> AMSTA-LC-LPIT/Tech Pubs, TACOM-RI 1 Rock Island Arsenal Rock Island, IL 61299-7630				FROM: <i>(Activity and location) (include ZIP code)</i>		
PART I - ALL PUBLICATIONS (EXCEPT RPSTL AND SC/SM) AND BLANK FORMS						
PUBLICATION/FORM NUMBER TB 9-2320-280-35-12			DATE 28 FEB. 2006		TITLE TECHNICAL BULLETIN INSTALLATION INSTRUCTIONS	
ITEM NO.	PAGE NO.	PARA-GRAPH	LINE NO.*	FIGURE NO.	TABLE NO.	RECOMMENDED CHANGES AND REASON <i>(Provide exact wording of recommended changes, if possible)</i>
<i>*Reference to line numbers within the paragraph or subparagraph.</i>						
TYPED NAME, GRADE, OR TITLE				TELEPHONE EXCHANGE/AUTOVON, PLUS EXTENSION		SIGNATURE

TO: <i>(Forward direct to addressee listed in publication)</i> AMSTA-LC-LPIT/Tech Pubs, TACOM-RI 1 Rock Island Arsenal Rock Island, IL 61299-7630	FROM: <i>(Activity and location) (include ZIP code)</i>	DATE:
---	--	--------------

PART II - REPAIR PARTS AND SPECIAL TOOLS LISTS AND SUPPLY CATALOGS/SUPPLY MANUALS

PUBLICATION/FORM NUMBER TB 9-2320-280-35-12	DATE 28 FEB. 2006	TITLE TECHNICAL BULLETIN INSTALLATION INSTRUCTIONS
---	-----------------------------	---

PAGE NO.	COLM NO.	LINE NO.	NATIONAL STOCK NUMBER	REFERENCE NO.	FIGURE NO.	ITEM NO.	TOTAL NO. OF MAJOR ITEMS SUPPORTED	RECOMMENDED ACTION

PART III - REMARKS *(Any general remarks or recommendations, or suggestions for improvement of publications and blank forms. Additional blank sheets may be used if more space is needed.)*

--

TYPED NAME, GRADE, OR TITLE	TELEPHONE EXCHANGE/AUTOVON, PLUS EXTENSION	SIGNATURE

RECOMMENDED CHANGES TO PUBLICATIONS AND BLANK FORMS For use of this form, see AR 25-30; the proponent agency is ODISC4.				Use Part II (reverse) for Repair Parts and Special Tools Lists (RPSTL) and Supply Catalogs/Supply Manuals (SC/SM).		DATE:
TO: <i>(Forward to proponent of publication or form) (include ZIP code)</i> AMSTA-LC-LPIT/Tech Pubs, TACOM-RI 1 Rock Island Arsenal Rock Island, IL 61299-7630				FROM: <i>(Activity and location) (include ZIP code)</i>		
PART I - ALL PUBLICATIONS (EXCEPT RPSTL AND SC/SM) AND BLANK FORMS						
PUBLICATION/FORM NUMBER TB 9-2320-280-35-12			DATE 28 FEB. 2006		TITLE TECHNICAL BULLETIN INSTALLATION INSTRUCTIONS	
ITEM NO.	PAGE NO.	PARA-GRAPH	LINE NO.*	FIGURE NO.	TABLE NO.	RECOMMENDED CHANGES AND REASON <i>(Provide exact wording of recommended changes, if possible)</i>
<i>*Reference to line numbers within the paragraph or subparagraph.</i>						
TYPED NAME, GRADE, OR TITLE				TELEPHONE EXCHANGE/AUTOVON, PLUS EXTENSION		SIGNATURE

TO: <i>(Forward direct to addressee listed in publication)</i> AMSTA-LC-LPIT/Tech Pubs, TACOM-RI 1 Rock Island Arsenal Rock Island, IL 61299-7630	FROM: <i>(Activity and location) (include ZIP code)</i>	DATE:
---	--	--------------

PART II - REPAIR PARTS AND SPECIAL TOOLS LISTS AND SUPPLY CATALOGS/SUPPLY MANUALS

PUBLICATION/FORM NUMBER TB 9-2320-280-35-12	DATE 28 FEB. 2006	TITLE TECHNICAL BULLETIN INSTALLATION INSTRUCTIONS
---	-----------------------------	---

PAGE NO.	COLM NO.	LINE NO.	NATIONAL STOCK NUMBER	REFERENCE NO.	FIGURE NO.	ITEM NO.	TOTAL NO. OF MAJOR ITEMS SUPPORTED	RECOMMENDED ACTION

PART III - REMARKS *(Any general remarks or recommendations, or suggestions for improvement of publications and blank forms. Additional blank sheets may be used if more space is needed.)*

TYPED NAME, GRADE, OR TITLE	TELEPHONE EXCHANGE/AUTOVON, PLUS EXTENSION	SIGNATURE

